

МИНИСТЕРСТВО ЗДРАВООХРАНЕНИЯ РЕСПУБЛИКИ БЕЛАРУСЬ
УЧРЕЖДЕНИЕ ОБРАЗОВАНИЯ
«ГОМЕЛЬСКИЙ ГОСУДАРСТВЕННЫЙ МЕДИЦИНСКИЙ УНИВЕРСИТЕТ»

Кафедра общей и биоорганической химии

В. А. ФИЛИПОВА, Л. В. ЧЕРНЫШЕВА, А. В. ЛЫСЕНКОВА

БИООРГАНИЧЕСКАЯ ХИМИЯ

**Учебно-методическое пособие
для студентов 1 курса лечебного факультета,
обучающихся на английском языке, медицинских вузов**

BIOORGANIC CHEMISTRY

**Teaching workbook
for the 1st year students of the Faculty of General medicine,
studying in English, of higher medical education institutions**

**Гомель
ГомГМУ
2015**

УДК 577.1(072)=111

ББК 24.1Я73

Ф 56

Рецензенты:

доктор технических наук, профессор, заведующий кафедрой химии
Белорусского государственного университета транспорта

А. С. Неверов;

кандидат химических наук, доцент, заведующая кафедрой химии
Гомельского государственного университета им. Ф. Скорины

Н. И. Дроздова

Филиппова, В. А.

Ф 56 Биоорганическая химия: учеб.-метод. пособие по курсу общей химии для студентов лечебного факультета, обучающихся на английском языке, медицинских вузов = Bioorganic chemistry: Teaching workbook for the 1st year students of the Faculty of General medicine, studying in English, of higher medical education institutions / В. А. Филиппова, Л. В. Чернышева, А. В. Лысенкова. — Гомель: ГомГМУ, 2015. — 248 с. ISBN 978-985-506-782-6

В учебно-методическом пособии изложены теоретические вопросы и приведены методики выполнения лабораторных работ. Для организации самостоятельной работы студентов представлены задачи и тестовые задания. В конце пособия даны необходимые справочные материалы и словарь важнейших физико-химических терминов.

Предназначено для студентов 1 курса лечебного факультета, обучающихся на английском языке, медицинских вузов.

Утверждено и рекомендовано к изданию научно-методическим советом учреждения образования «Гомельский государственный медицинский университет» 29 декабря 2014 г., протокол № 8.

УДК 577.1(072)=111

ББК 24.1Я73

ISBN 978-985-506-782-6

© Учреждение образования
«Гомельский государственный
медицинский университет», 2015

CONTENT

| | |
|--|----|
| PART I. FUNDAMENTALS OF STRUCTURE AND REACTIVITY OF ORGANIC COMPOUNDS | 8 |
| <i>Chapter 1. Introduction into bioorganic chemistry</i> | 8 |
| 1.1. Introduction | 8 |
| 1.2. Classification of Organic Compounds | 9 |
| 1.3. Nomenclature of Organic Compounds..... | 15 |
| 1.4. Exercises for the Self-Control | 18 |
| <i>Chapter 2. Configuration and conformations of organic substances</i> | 19 |
| 2.1. The Theory of the Chemical Structure of Organic Compounds | 19 |
| 2.2. Isomerism and its Types..... | 20 |
| 2.3. Configuration and Conformation of Open-chain Organic Compounds | 21 |
| 2.4. Conformation of Cyclic Compounds | 27 |
| 2.5. Exercises for the Self-Control | 28 |
| <i>Chapter 3. Conjugated and aromatic systems</i> | 29 |
| 3.1 Conjugated Systems | 29 |
| 3.2. Aromatic Systems | 32 |
| 3.3. Inductive and Resonance Effects | 39 |
| 3.4. Exercises for the Self-Control | 40 |
| <i>Chapter 4. Classification and mechanism of organic reactions</i> | 41 |
| 4.1. Classification of Chemical Reactions and Reagents..... | 41 |
| 4.2. Reactions of Radical Substitution — S_r | 43 |
| 4.3. Electrophilic Addition to Alkenes— A_e | 44 |
| 4.4. Exercises for the Self-Control | 45 |
| <i>Chapter 5. Acidity and basicity of organic compounds</i> | 47 |
| 5.1. Acidity and Basicity Rewired | 47 |
| 5.2. Acidity of Organic Compounds | 48 |
| 5.3. Basicity of Organic Compounds | 54 |
| 5.4 Amphoteric Properties of Organic Compounds..... | 56 |
| 5.5. Laboratory Work “Acidity and basicity of organic compounds” | 60 |
| 5.6. Exercises for the Self-Control | 61 |
| PART II. GENERAL REGULARITIES OF ORGANIC COMPOUNDS REACTIVITY AS THE CHEMICAL BASIS OF THEIR BIOLOGICAL FUNCTIONING | 62 |
| <i>Chapter 6. Reactions of radical substitution</i> — S_R | 62 |
| 6.1. Radical Substitution at sp^3 -hybridized Carbon Atom | 62 |
| 6.2. Halogenation of Alkanes | 63 |
| 6.3 Exercises for the Self-Control | 63 |

| | |
|--|-----|
| Chapter 7. Electrophilic addition to unsaturated hydrocarbons — A_E | 67 |
| 7.1. The Mechanism of Electrophilic Addition to a Multiple Bond — A_E | 67 |
| 7.2. Electrophilic Addition to Alkenes and Alkynes | 68 |
| 7.3. The Addition of Unsymmetrical Reagents to Unsymmetrical Alkenes and Alkynes..... | 70 |
| 7.4. Electrophilic Addition to Conjugated Systems | 72 |
| 7.5. Exercises for the Self-Control..... | 73 |
| Chapter 8. The Mechanism of Electrophilic Aromatic Substitution | 73 |
| 8.1 The Mechanism of Electrophilic Aromatic Substitution — S_E | 73 |
| 8.2. Ring-Activating and Ring-Deactivating Substituents..... | 77 |
| 8.3. Electrophilic Aromatic Substitution in Polycyclic Aromatic Hydrocarbons | 79 |
| 8.4. Electrophilic Substitution in Heteroaromatic Compounds | 80 |
| 8.5. Exercises for the Self-Control..... | 82 |
| Chapter 9. Nucleophilic substitution and elimination in competition | 83 |
| 9.1. General Concepts | 83 |
| 9.2. Nucleophilic Aliphatic Substitution..... | 85 |
| 9.3. Elimination Reactions | 88 |
| 9.4. Exercises for the Self-Control..... | 91 |
| Chapter 10. Aldehydes and Ketones | 92 |
| 10.1. General Characteristics of Aldehydes and Ketones..... | 92 |
| 10.2. Nucleophilic Addition to Carbonyl Group — A_N | 95 |
| 10.3. Reduction and Oxidation of Carbonyl Compounds..... | 100 |
| 10.4. Laboratory Work “Aldehydes and Ketones” | 102 |
| 10.5. Exercises for the Self-control..... | 104 |
| Chapter 11. Carboxylic Acids | 105 |
| 11.1. Classification of Carboxylic Acids | 105 |
| 11.2. Chemical Properties of Carboxylic Acids — S_n | 108 |
| 11.3. Esters and their Hydrolysis | 112 |
| 11.4. Laboratory Work “Carboxylic Acids” | 117 |
| 11.5. Exercises for the Self-control..... | 118 |
| Chapter 12. Specific Properties of Aliphatic Poly- and Heterofunctional Compounds | 120 |
| 12.1. General Concepts | 120 |
| 12.2. Optical Isomerism | 124 |
| 12.3. Specific Properties of Heterofunctional Compounds..... | 130 |
| 12.4. Amino Alcohols and their Biological Functions..... | 132 |
| 12.5. Laboratory Work “Aliphatic hetero functional compounds” | 134 |
| 12.6. Exercises for the Self-control..... | 135 |

| | |
|---|-----|
| Chapter 13. Heterofunctional Aromatic and Heteroaromatic Compounds | 136 |
| 13.1. Heterofunctional Aromatic Compounds | 136 |
| 13.2. Aromatic Heterocycles with One Nitrogen Atom..... | 138 |
| 13.3. Aromatic Heterocycles with Two Nitrogen Atoms | 144 |
| 13.4. Laboratory work “Hetero functional aromatic and heterocyclic compounds” | 148 |
| 13.5. Exercises for the Self-Control..... | 149 |
| PART III. BIOPOLYMERS AND BIOREGULATORS | 150 |
| Chapter 14. Lipids | 150 |
| 14.1. Classification of the lipids..... | 150 |
| 14.2. Saponifiable lipids..... | 155 |
| 14.3. Complex Saponifiable Lipids..... | 158 |
| 14.4. Chemical Properties of Saponifiable Lipids | 162 |
| 14.5. Laboratory work “Lipids” | 165 |
| 14.6. Exercises for the Self-Control..... | 166 |
| Chapter 15. Nonsaponifiable lipids | 167 |
| 15.1 Terpenes | 167 |
| 15.2 Steroids..... | 169 |
| 15.3. Exercises for the Self-Control..... | 176 |
| Chapter 16. Carbohydrates | 177 |
| 16.1. Classification of the Carbohydrates | 177 |
| 16.2. Monosaccharides | 178 |
| 16.3. Chemical Properties | 181 |
| 16.4. Laboratory work “Monosaccharides” | 185 |
| 16.5. Exercises for the Self-Control..... | 186 |
| 16.6. Classification Oligo- and Polysaccharides..... | 186 |
| 16.7. Disaccharides..... | 186 |
| 16.8. Chemical Properties of Disaccharides | 188 |
| 16.9. Homopolysaccharides | 189 |
| 16.10. Heteropolysaccharides | 191 |
| 16.11. Laboratory work “Di-and Polysaccharides“ | 193 |
| 16.12. Exercises for the Self-Control..... | 194 |
| Chapter 17. α - amino acids, peptides and proteins | 195 |
| 17.1. α -Amino Acids..... | 195 |
| 17.1.1. Naturally Occurring Amino Acids | 195 |
| 17.1.2. Stereoisomerism of α -Amino Acids..... | 195 |
| 17.1.3. Biosynthesis of α -Amino Acids | 202 |

| | |
|---|-----|
| 17.1.4. The Acid-Base Properties of Amino Acids..... | 203 |
| 17.1.5. Chemical Properties of α -Amino Acids..... | 204 |
| 17.1.6. Biologically Important Chemical Reactions of α -Amino Acids..... | 205 |
| 17.2. Peptides and Protein | 207 |
| 17.2.1. Electron Structure of the Peptides Bond | 207 |
| 17.2.2. Primary Structure of Proteins Determination..... | 212 |
| 17.2.3. Strategy of Peptide Synthesis | 213 |
| 17.2.4. The Spatial Structure of Proteins | 215 |
| 17.2.5. Test Reactions on α -Amino Acids and Proteins | 218 |
| 17.3. Laboratory work “ α -Amino acids, peptides and proteins” | 219 |
| 17.4. Exercises for the Self-Control..... | 220 |
| Chapter 18. Nucleotides and nucleic acids | 221 |
| 18.1. General Structure of Nucleic Acids | 221 |
| 18.2. Nucleosides | 224 |
| 18.3. Mononucleotides | 224 |
| 18.4. Primary and Secondary Structure of Nucleic Acids | 226 |
| 18.5. Nicotinamide Adenine Dinucleotide (NAD) | 231 |
| 18.6. ATP | 233 |
| 18.7. Exercises for the Self-Control..... | 235 |
| Glossary | 236 |
| Appendix 1. Formulas for chemistry seminars | 245 |
| Appendix 2. The most important functional groups and the decrease of their priority | 246 |
| Appendix 3. Inductive and Resonance effects | 246 |
| Appendix 4. K_a and pK_a for acid..... | 247 |
| Appendix 5. K_b values..... | 247 |
| Literature | 248 |

PREFACE

Organic chemistry is one of the fundamental interdisciplinary fields of medicine. It plays an important role in many areas of science — from physics and biology to biochemistry and medicine. Bioorganic chemistry is the section of organic chemistry, which studies the chemical processes in living cells, thus being the instrument of various studies of living matter components. Without its knowledge it is impossible to imagine a modern competent medical doctor.

This handbook is a short course of bioorganic chemistry, containing all of its key concepts. This text is intended for students studying the course of bioorganic chemistry in medical universities, and for physicians who wish to study chemistry at a higher level.

PART I

FUNDAMENTALS OF STRUCTURE AND REACTIVITY OF ORGANIC COMPOUNDS

CHAPTER 1

INTRODUCTION INTO BIOORGANIC CHEMISTRY

After reading this chapter, you should be able to:

- define organic and bioorganic chemistry;
- describe classification of organic substances according to framework of their molecules and nature of functional groups;
- discuss radical-functional and IUPAC nomenclature of organic compounds;
- define mono-, poly- and heterofunctional compounds.

1.1. Introduction

Bioorganic chemistry studies structure and chemical properties of bio-active compounds that play an important role in metabolic processes.

As an independent science bioorganic chemistry was developed in the second half of the XX century. Nowadays it is a rapidly growing scientific discipline which deals with the study of biological processes using chemical methods. It is very much interdisciplinary science and combines organic chemistry, biochemistry, pharmacology and physiology. While biochemistry aims at understanding biological processes using chemistry, bioorganic chemistry attempts to expand organic-chemical researches (that is, structures, synthesis, and kinetics) toward biology. The main objects of bioorganic chemistry studying are biologically active compounds: biopolymers and bio regulators.

Biopolymers are natural macromolecular compounds that behave as structural basis for all living systems. They are peptides, proteins, polysaccharides and nucleic acids.

Bio regulators are chemical compounds that control metabolic processes *in vivo*. They are hormones, enzymes, vitamins and numerous pharmaceuticals.

Medicine and pharmaceutical research are some of the biggest consumers of bioorganic chemistry expertise. Sometimes this comes in the form of creating certain drugs or medicinal cures for discreet conditions, but it can also come as basic understanding of the roots of certain conditions. Being able to explain the precise science behind an ailment is often a precursor to finding a workable solution or treatment plan.

The study of bioorganic chemistry is both theoretical and practical. On the theory side of things, scientists must understand how different structures will re-

late to one another, particularly with respect to the laws governing cell synthesis, synapse control, and other elements of cellular-level reactions. The field also encompasses a lot of practical science, requiring researchers and lab technicians to actually execute, observe, and create. Expertise in both disciplines is usually required for success.

Looking at several graduate programs in biochemistry, one finds that the biochemical research can be expressed in a variety of terms, often with a focus on biomedical research and food science. Examples of the first include areas such as Molecular Medicine, Biochemistry of Cancer, Neuroscience and Aging, Pharmacology, Toxicology, Stem Cell Development, and Immunochemistry. The second can include categories such as Enzymology, Nutrition and Metabolism; Food Toxicology; Wine-making Biochemistry; and Brewing Biochemistry.

1.2. Classification of Organic Compounds

Organic chemistry started as the chemistry of life, when that was thought to be different from the chemistry in the laboratory. Then it became the chemistry of carbon compounds. Nowadays it is the chemistry of carbon compounds along with other elements such as hydrogen, oxygen, nitrogen, and sometimes sulfur, phosphorus, halogens, and few others. This definition broadens the scope of the subject to include not only compounds from nature but also synthetic compounds — compounds invented by organic chemists and prepared in their laboratories.

At the time of writing there were about 16 million organic compounds known, but there is no limit (except the number of atoms in the universe). According to statistics a new organic compound is synthesized every month in the world. In order not to sink in the ocean of organic substances we must understand their classification and nomenclature.

Organic compounds are classified

- by their molecular framework (Figures 1.1 and 1.2);
- by the nature of their functional groups.

According to their molecular framework organic compounds fall into two categories: acyclic and cyclic.

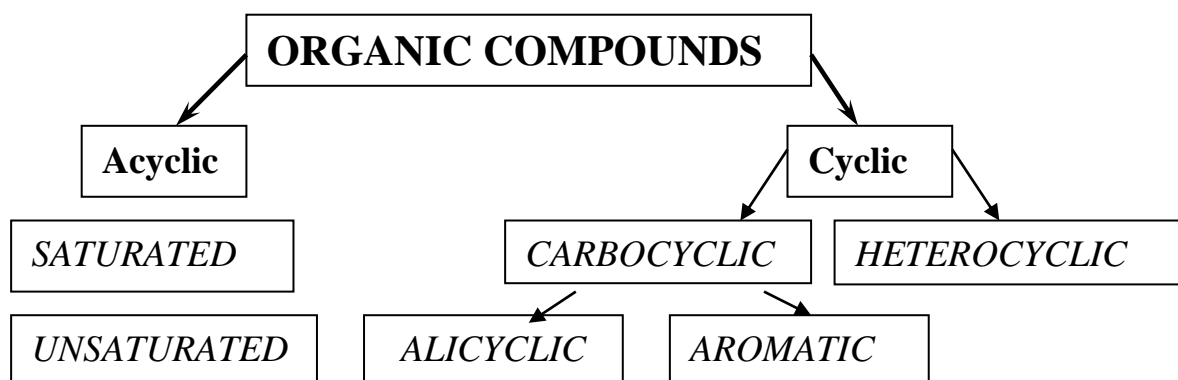

Figure 1.1 — Classification of organic compounds

Acyclic compounds are open chain molecules while cyclic compounds contain rings of atoms. Acyclic compounds are of two types: saturated and unsaturated. Figure 1.2 represents the homologous series of acyclic hydrocarbons.

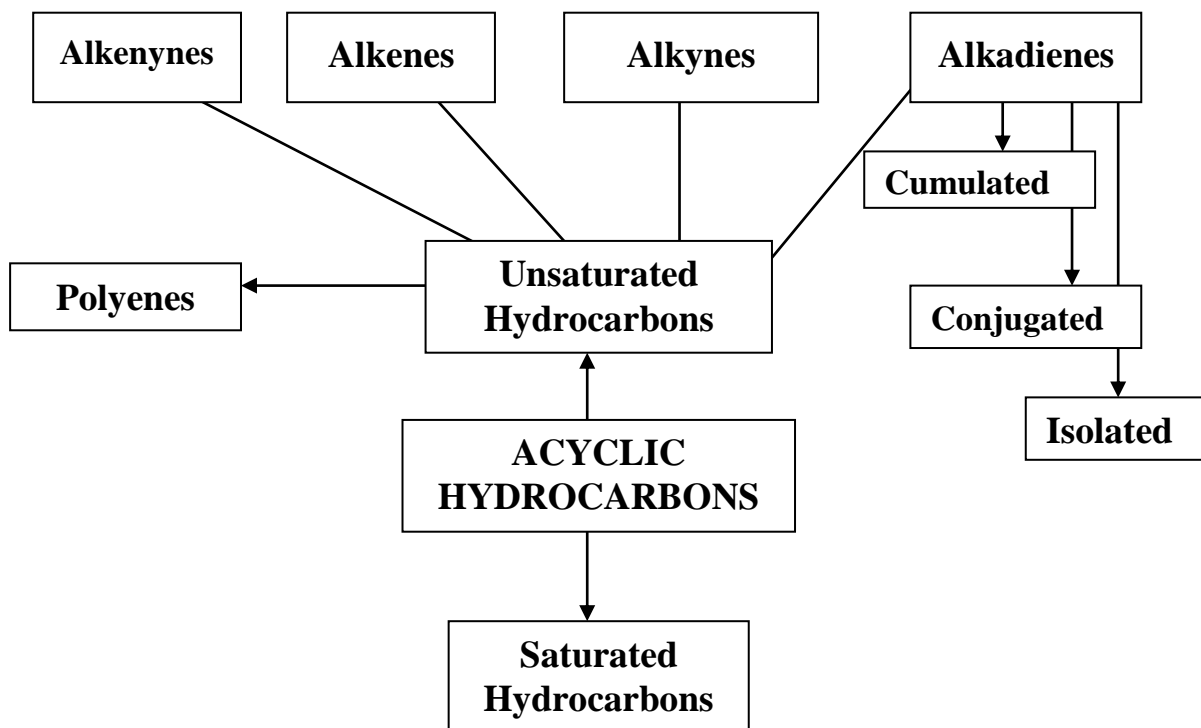

Figure 1.2 — Classification of acyclic compounds

Saturated hydrocarbons (alkanes) contain only single carbon-carbon bonds. Their general formula is C_nH_{2n+2} . The first member of their homologous series is methane CH_4 .

Unsaturated hydrocarbons contain **multiple** (double and triple) carbon-carbon bonds.

Alkenes contain one carbon-carbon double bond. General formula is C_nH_{2n} . Ethene $CH_2 = CH_2$ is the first member of their homologous series.

Alkynes contain one carbon-carbon triple bond. General formula is C_nH_{2n-2} . Ethyne $CH \equiv CH$ is the first member of their homologous series.

Alkadienes contain two carbon-carbon double bonds. General formula for dienes is C_nH_{2n-2} . Three types of dienes are distinguished:

- with isolated double bonds, for example

$$H_2C=CH-CH_2-CH=CH_2$$
 pentadiene-1,4
- with conjugated double bonds, for example

$$H_2C=CH-CH=CH-CH_3$$
 pentadiene-1,3
- with cumulated double bonds, for example

$$H_2C=C=CH-CH-CH_3$$

pentadiene-1,2
Alkenynes contain one double and one triple bond, for example



butene-1-yne-3

Alkadiynes contain two triple bonds, for example



butadiyne-1,3

Polyenes contain several double bonds, for example



heptatriene-1,3,5

Carbocyclic compounds contain rings of carbon atoms. Nonaromatic carbocyclic compounds are defined as alicyclic. Cycloalkanes are the simplest representatives of cyclic compounds. They contain only single carbon-carbon bonds in their molecules. General formula is C_nH_{2n} . Examples of the cycloalkanes are given below:



Cyclopropane



Cyclobutane

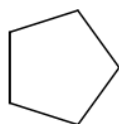

Cyclopentane

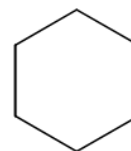

Cyclohexane

Cycloalkenes are compounds that contain only one double carbon-carbon bond. General formula is $\text{C}_n\text{H}_{2n-2}$. For example:



Cyclopropene

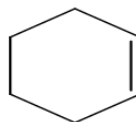

Cyclohexene

Cycloalkadienes are compounds with two double bonds in their molecules. Their general formula is $\text{C}_n\text{H}_{2n-4}$. For example:

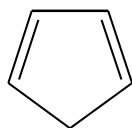

Cyclopentadiene-1,3

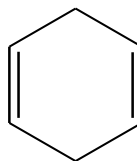

Cyclohexadiene-1,4

Alicyclic compounds may contain two or several cycles. Bicyclic compounds fall into three categories:

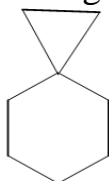

Spiro-rings

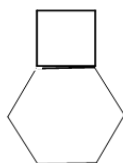

Fused-rings

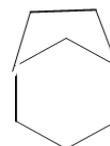

Bridged-rings

spiro-[2, 5]-octane bicyclo-[4, 2, 0]-octane bicycle-[3, 2, 1]-octane

Heterocyclic compounds contain at least one hetero atom in the ring, an atom that is not carbon. The most common heteroatoms are oxygen, nitrogen, and sulfur, but heterocyclic compounds with other elements are also known. The examples of heterocyclic compounds with heteroatom are given below:

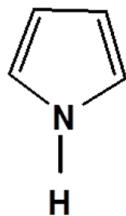

Pyrrole

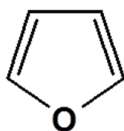

Furan

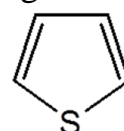

Thiophene

Aromatic hydrocarbons contain benzene rings:

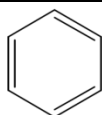

Benzene

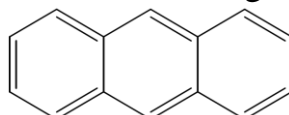

Anthracene

Classification According to Functional Groups

Functional group is an atom or small group of atoms in a molecule that gives the molecule characteristic chemical properties regardless of the molecular framework to which it is attached. The functional groups determine the way the molecule works both chemically and biologically. According to the number of functional groups in a molecule there are:

(a) monofunctional compounds that contain only one functional group, e.g. ethanol $\text{CH}_3\text{CH}_2\text{OH}$;

(b) polyfunctional compounds that contain several identical functional group, e.g. glycerol $\text{C}_3\text{H}_5(\text{OH})_3$;

(c) heterofunctional compounds that contain several different functional groups, e.g. amino acid glycine $\text{NH}_2\text{CH}_2\text{COOH}$.

Some of the main functional groups are listed in table 1.1.

Table 1.1 — The main functional groups

| Functional group | Class of compound | General formula |
|----------------------------------|-----------------------|--|
| -F, -Cl, -Br, -I | Halogenated compounds | R – Hal |
| -OH | Alcohols, phenols | R – OH |
| -OR | Eathers | R – OR |
| -SH | Thiols | R – SH |
| -SR | Thioeathers | R- SR |
| -SO ₃ H | Sulfonic acids | R – SO₃H |
| -NH ₂ -NH- >NH- | Amines | R – NH₂ R₂NH R₃N |
| -NO ₂ | Nitro compounds | R – NO₂ |

| Functional group | Class of compound | General formula |
|--|----------------------|--|
| -CN | Nitriles | R - CN |
| >C=O | Aldehydes Ketones | $\begin{array}{c} \text{O} \\ \parallel \\ \text{R}-\text{C}-\text{H} \\ \text{R}-\text{C}-\text{R}' \\ \parallel \\ \text{O} \end{array}$ |
| $\begin{array}{c} \text{O} \\ \parallel \\ -\text{C} \\ \backslash \\ \text{OH} \end{array}$ | Carboxylic acids | $\begin{array}{c} \text{O} \\ \parallel \\ \text{R}-\text{C} \\ \backslash \\ \text{OH} \end{array}$ |
| $\begin{array}{c} \text{O} \\ \parallel \\ -\text{C} \\ \backslash \\ \text{OR}' \end{array}$ | Esters | $\begin{array}{c} \text{O} \\ \parallel \\ \text{R}-\text{C} \\ \backslash \\ \text{OR}' \end{array}$ |
| $\begin{array}{c} \text{O} \\ \parallel \\ -\text{C} \\ \backslash \\ \text{SR}' \end{array}$ | Thioesters | $\begin{array}{c} \text{O} \\ \parallel \\ \text{R}-\text{C} \\ \backslash \\ \text{SR}' \end{array}$ |
| $\begin{array}{c} \text{O} \\ \parallel \\ -\text{C} \\ \backslash \\ \text{NH}_2 \end{array}$ | Acid amides | $\begin{array}{c} \text{O} \\ \parallel \\ \text{R}-\text{C} \\ \backslash \\ \text{NH}_2 \end{array}$ |

Ether and Anesthesia



Prior to the 1840s, pain during surgery was relieved by various methods (asphyxiation, pressure on nerves, administration of narcotics or alcohol), but on the whole it was almost worse torture to undergo an operation than to endure the disease. Modern use of anesthesia during surgery has changed all that. Anesthesia stems from the work / of several physicians in the mid-nineteenth century. The earliest experiments used nitrous oxide, ether, or chloroform. Perhaps the best known of these experiments was the removal of a tumor from the Jaw of a patient anesthetized by ether, performed by Boston dentist William T. G. Morton in 1846 (Figure 1.3).

Anesthetics fall into two major categories: general and local. **General anesthetics** are usually administered to accomplish three ends; insensitivity to pain (analgesia), loss of consciousness, and muscle relaxation. Gases such as nitrous oxide and cyclopropane and volatile liquids such as ether are administered by inhalation, but other general anesthetics such as barbiturates are injected intravenously.

The exact mechanism by which anesthetics affect the central nervous system is not completely known. Unconsciousness may result from several factors: changes in the properties of nerve cell membranes, suppression of certain enzymatic reactions, and solubility of the anesthetic in lipid membranes.

A good inhalation anesthetic should vaporize readily and have appropriate solubility in the blood and tissues. It should also be stable, inert, nonflammable, potent, and minimally toxic. It should have an acceptable odor and cause minimal side effects such as nausea or vomiting. No anesthetic that meets **all** these specifications has yet been developed. Although **diethyl ether** is perhaps the best known general anesthetic to the layperson, it fails on several counts (flammability, side effects of nausea or vomiting, and relatively slow action). It is quite potent, however, and produces good analgesia and muscle relaxation. The use of ether at present is rather limited, mainly because of its undesirable side effects. **Halothane**, CF_3CHBrCl , comes closest to an ideal inhalation anesthetic at present, but halogenated ethers such as **enflurane**, $\text{CF}_2\text{H-O-CF}_2\text{CHClF}$, are also used.

Local anesthetics are either applied to body surfaces or injected near nerves to desensitize a particular region of the body to pain. The best known of these anesthetics is procaine (Novocain), an aromatic amino-ester (see chapter 13)

The discovery of anesthetics enabled physicians to perform surgery with deliberation and care, leading to many of the advances of modern medicine.



Figure 1.3 — Dr. William, T. G. Morton making the first public demonstration of anesthetization with ether



1.3. Nomenclature of Organic Compounds

The process of naming compounds is called **nomenclature** and a study of organic nomenclature is part of any course in organic chemistry. In the early days of organic chemistry, each new compound was given a name that was usually based on its source or use. Examples include limonene (from lemons), lactose (milk sugar) isolated from milk, palmitic acid isolated from palm oil, pyruvic acid prepared by pyrolysis of grape acid, malic acid was first isolated from unripe apples, glycine (from Greek) is sweat. Even today, this method of naming may be used to give a short, simple name to a molecule with a complex structure. It became clear many years ago, however, that one could not rely on common or trivial names and that a systematic method for naming compounds was needed. Eventually in 1957, internationally recognized systems of nomenclature were devised by a commission of the International Union of Pure and Applied Chemistry; they are known as the **IUPAC systems**. This system is widely used in organic chemistry, biochemistry and pharmacology.

To use a systematic IUPAC nomenclature it is necessary to know the meaning of some terms, such as organic radicals, parent structures and substituents.

Organic radical is a molecular fragment with an odd number of unshared electrons. It is generated by cleaving one or more hydrogen atoms from a molecule. The names of some hydrocarbon radicals are given in table 1.2.

Table 1.2 — The names of some hydrocarbon radicals

| Hydrocarbon radicals | The names of hydrocarbon radicals |
|---|-----------------------------------|
| $-\text{CH}_3; -\text{C}_2\text{H}_5$ | Methyl, Ethyl |
| $\begin{array}{c} -\text{CH}-\text{CH}_3 \\ \\ \text{CH}_3 \end{array}$ | Isopropyl |
| $\begin{array}{c} -\text{CH}_2-\text{CH}-\text{CH}_3 \\ \\ \text{CH}_3 \end{array}$ | Isobutyl |
| $\begin{array}{c} -\text{CH}-\text{CH}_2-\text{CH}_3 \\ \\ \text{CH}_3 \end{array}$ | Secondary butyl |
| $\begin{array}{c} \text{CH}_3 \\ \\ -\text{C}-\text{CH}_3 \\ \\ \text{CH}_3 \end{array}$ | tert-Butyl |
| $-\text{CH}=\text{CH}_2$ | Vinyl |
| $-\text{C}\equiv\text{CH}$ | Ethylyl |
| $-\text{CH}_2-\text{CH}=\text{CH}_2$ | Allyl |
|  | Phenyl |
| $-\text{CH}_2-$  | Benzyl |

Parent structure is the longest chain of carbon atoms or a cycle.

Substituents are functional groups or radicals attached to the parent structure.

According to IUPAC nomenclature the naming of an organic compound is fulfilled in the following order:

(1) a senior functional group and a parent structure are determined. A senior functional group is chosen according to the principle of groups' seniority (Appendix 1);

(2) the parent structure is numbered in such a way that the senior functional group receives the lowest possible number. In heterocyclic compounds the numeration starts from a hetero atom;

(3) give the name of the parent structure, indicating the senior functional group by a suffix. The degree of the parent structure saturation is indicated by suffixes *ane* (the molecular framework is saturated), *ene* (the molecular framework contains a carbon-carbon double bond) and *yne* (the molecular framework contains a carbon-carbon triple bond);

(4) the substituents are named in a prefix in an alphabetic order.

The organic compound is named according to the scheme given in table 1.3.

Table 1.3 — Naming of organic compounds according to IUPAC nomenclature

| The prefix | THE IMPORTANT STRUCTURE | | THE ENDING |
|--|--|---------------------------|------------------------------|
| | root name | suffix | The senior functional groups |
| Hydrocarbon radicals and junior functional groups in alphabetic order. Cl, Br, I, F, NO₂, OR, SR are in prefix only | Parent chain: the longest carbon-carbon chain or a cycle | The degree of saturation: | |
| | | -ane | |
| | | -ene | |
| | | -yne | |

To understand better the given information let's consider the IUPAC names of the following compounds.

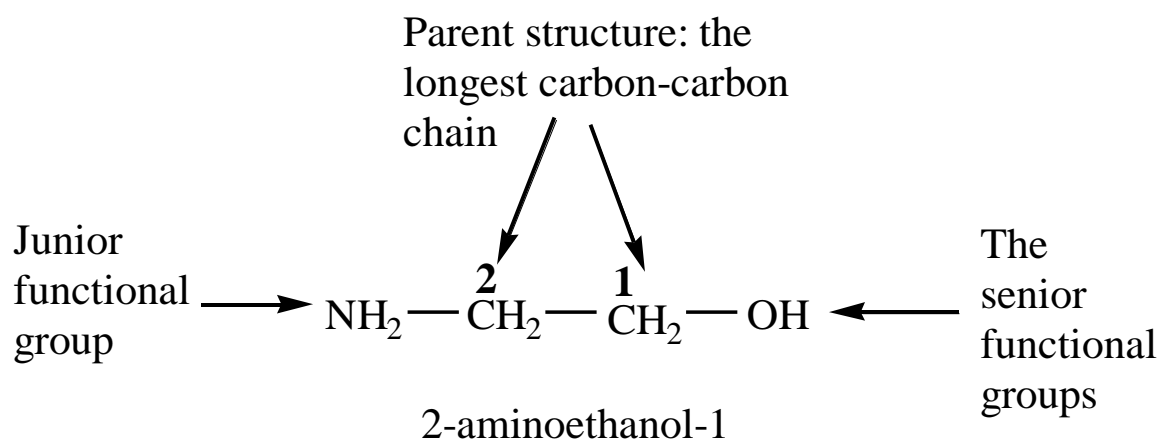

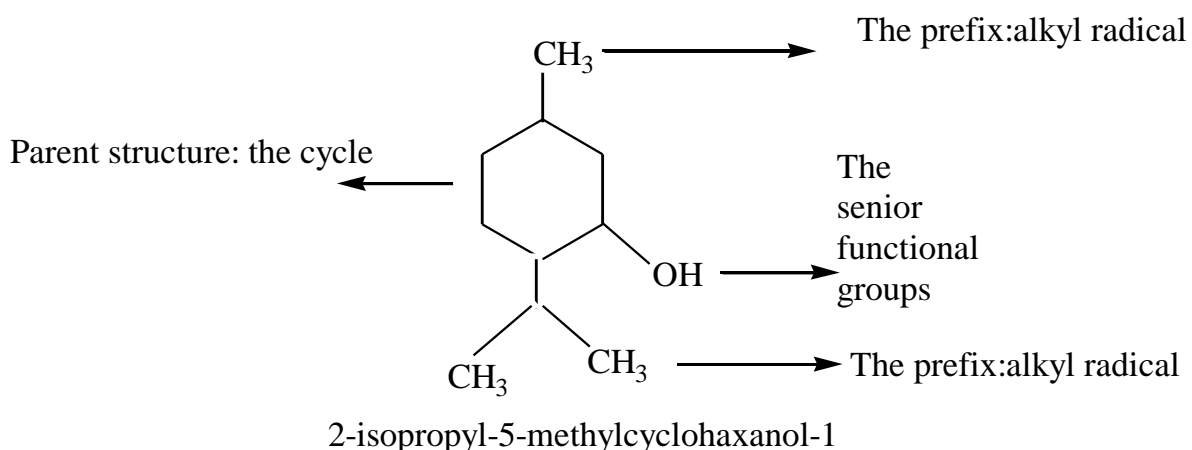
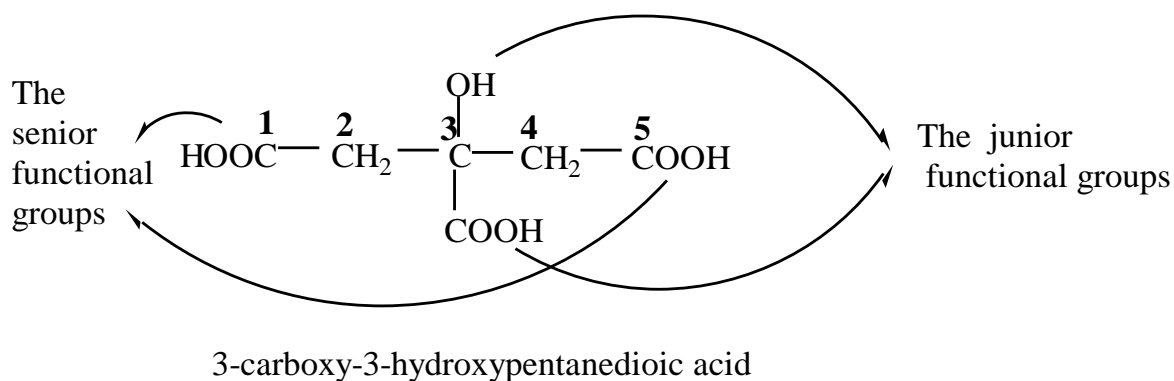
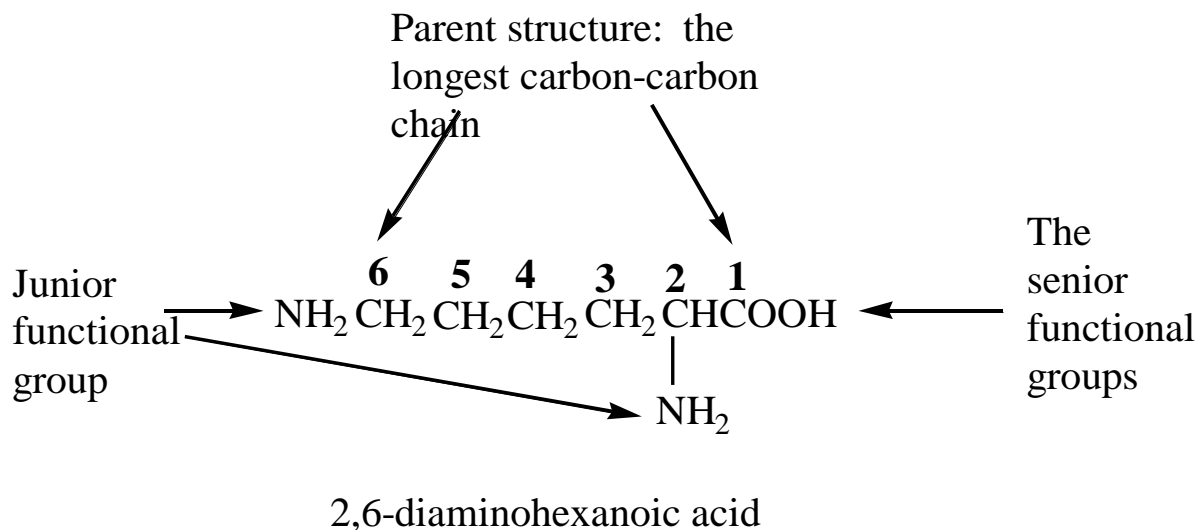

Radical-functional nomenclature is applied not so often as IUPAC systematic nomenclature. Generally it is used for certain classes of organic compounds — alcohols, ketones, ethers and others. The name of a hydrocarbon radical is followed by the name of organic compound's homologous series. For example:

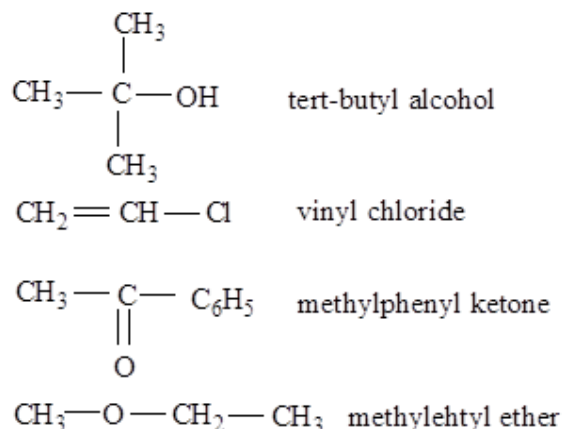

Outlined rules should serve as a constant guide in the follow-up study of specific classes of organic compounds nomenclature and their individual representatives. Knowledge of the general rules of nomenclature is of great importance, because according to them are constructed names of drugs that doctors encountered in professional practice.

1.4. Exercises for the Self-Control

1. Write the structural formulas for the following organic compounds:

- 2-amino-3-phenylpropanoic acid;
- propenal;
- 3,3,4-trimethylhexene-1;
- 2-aminopentanedioic acid;
- 2-amino-4-methylthiobutanoic acid;
- 2-amino-3-hydroxypropanoic acid;
- 3,3-diethyloctyne-1;
- butanone-2;
- 1,1-diethyl-4-isopropylcyclohexane.

2. Give the systematic names to the following organic compounds:

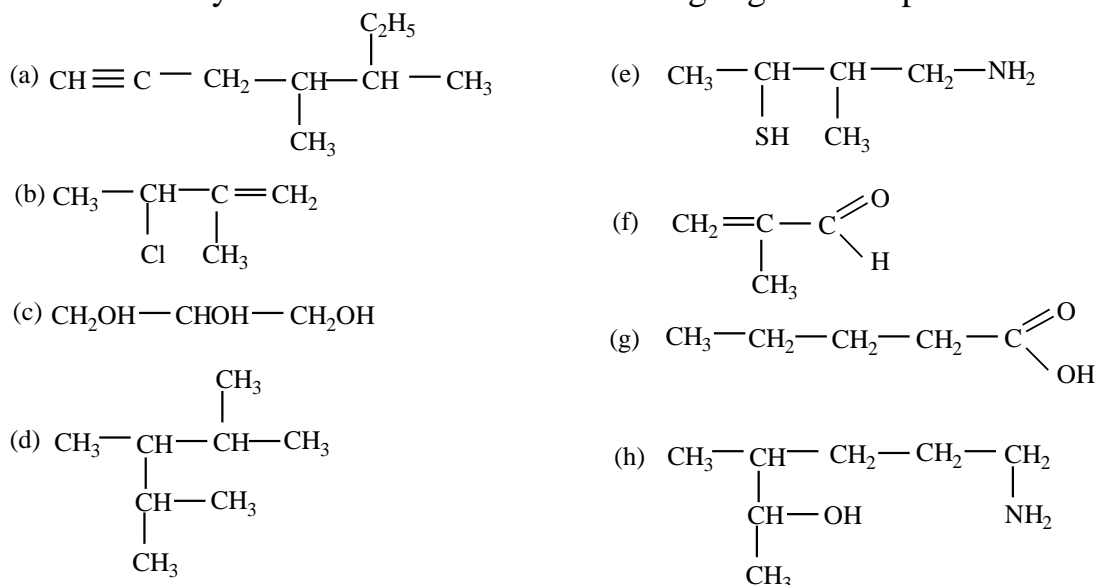

CHAPTER 2

CONFIGURATION AND CONFORMATIONS OF ORGANIC SUBSTANCES

After reading this chapter, you should be able to:

- discuss the main positions of the Butlerov's theory of the chemical structure;
- define isomerism and its types;
- describe conformations and configurations of acyclic and cyclic molecules;
- perform conformational analysis of alkanes and their derivatives;
- fulfill conformational analysis of cycloalkanes and their derivatives.

2.1. The Theory of the Chemical Structure of Organic Compounds

19 September 1861 year on the 36-th convention of German naturalists A.M. Butlerov promulgated his theory in the report «On the Chemical Structure of Substance».

Alexander Butlerov (September 15, 1828 — August 17, 1886) was a Russian chemist, one of the principal creators of the theory of chemical structure (1857–1861), the first to incorporate double bonds into structural formulas, the discoverer of hexamine (1859), and the discoverer of the formose reaction. He first proposed the idea possible tetrahedral arrangement of valence electrons in carbon in 1862.



The main positions of Butlerov's theory are the following:

- all atoms in molecules of organic compounds are bound with each other in determined sequences in accordance with their valence. **Chemical structure** is a certain order in the alternation of atoms in the molecules. Chemical structure is represented by structural and abbreviated structural formulas. For example, the structural formula and the abbreviated structural formula for butane are:

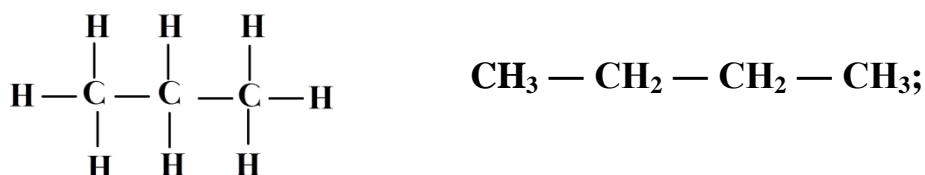

- physical and chemical properties of organic compounds depend not only upon a number of atoms in their molecules but also upon their chemical structure;

- mutual influence of atoms in a molecule significantly affect the properties of organic substances.

2.2. Isomerism and Its Types

Isomerism is the phenomenon of the existence of substances with an identical composition but with different chemical structure or different arrangement of atoms in space (figure 2.1).

Chemists know two important types of isomers:

- structural (constitutional) isomers have the same molecular formula but different structural formulas;
- stereoisomers are molecules with identical attachment of atoms but different arrangement of atoms in space.

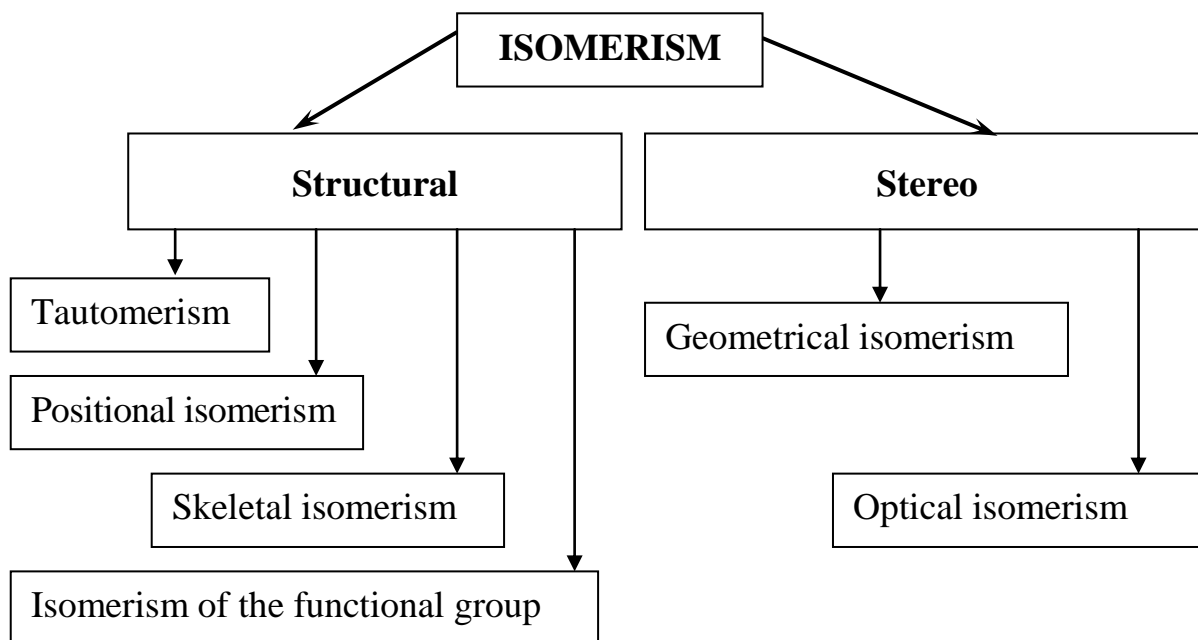
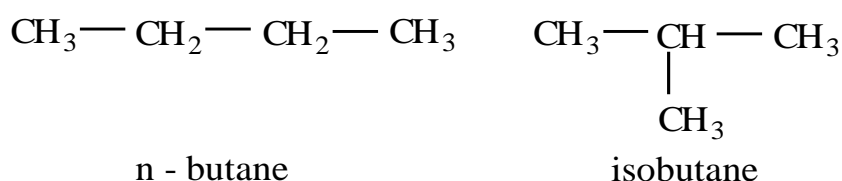

Figure 2.1 — Types of isomerism

The following types of structural isomerism occur:

(a) **skeletal isomerism**: isomers differ in their molecular framework. For example,



(b) **positional isomerism**: isomers differ in position of multiple bonds and functional groups. For example,

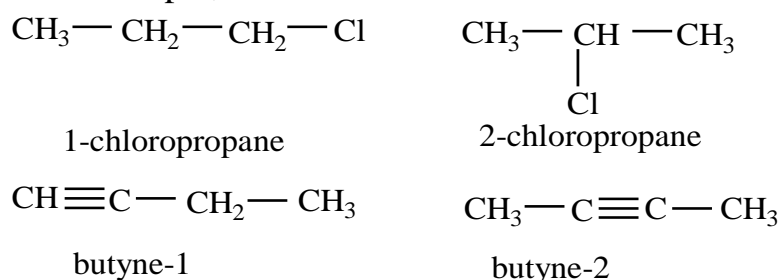

(c) **isomerism of functional groups.** For example, an empiric formula C_3H_8O corresponds both to the alcohol and the ether:



(d) **tautomerism** is a dynamic reversible isomerism. Tautomers are structural isomers that differ in location of a proton and a double bond. Several types of tautomerism are distinguished:

• **keto-enol tautomerism:** aldehydes and ketones may exist as an equilibrium of two forms, called the keto- and the enol-forms:

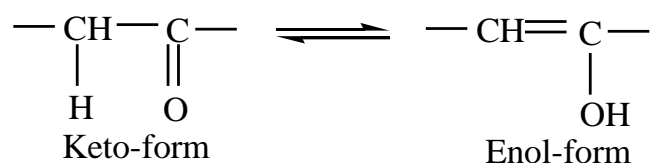

• **lactam-lactim tautomerism:**

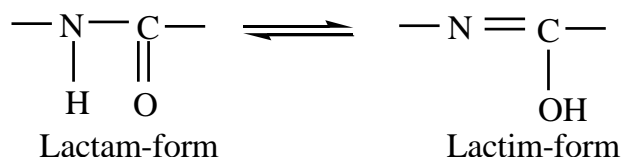

The following types of stereo isomerism occur:

(a) **geometrical isomers** appears in alkenes and their derivatives

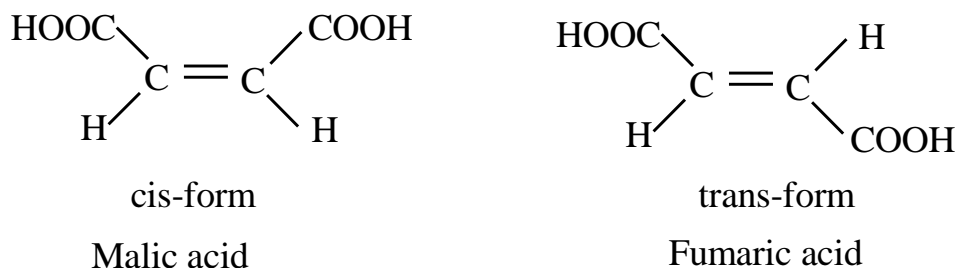

In cis-isomers both substituents are situated at one side of a double bond, but in trans-isomers they are located at different sides. Trans-isomers are more stable than cis-isomers.

(b) **optical isomerism** (we shall discuss this phenomenon in Chapter 12.2).

2.3. Configuration and Conformation of Open-Chain Organic Compounds

In order to characterize the three-dimensional structure of molecules such notations as configuration and conformation are used. **Configuration** is a stereo arrangement of atoms in a molecule without differences generated by the rotation of one carbon atom with respect to the other carbon atom about the ordinary

C-C bonds. Configuration of molecules depends upon a carbon atom's hybridization type. Thus sp^3 -hybridization of carbon atoms in alkanes and their derivatives generates tetrahedral configuration of their molecules with tetrahedral angle between bonds 109.5° .

To represent the configuration of molecules chemists have developed the **stereo chemical formulas** or the **wedge-and-dash representations**. The wedges represent chemical bonds that project out of the plane of a paper toward a viewer. The dashed wedges represent the bonds that are projecting away from a viewer behind the plane. The lines are bonds in the plane of the paper. Stereo structure for methane and its wedge-and-dash representation are given in the figure 2.2:

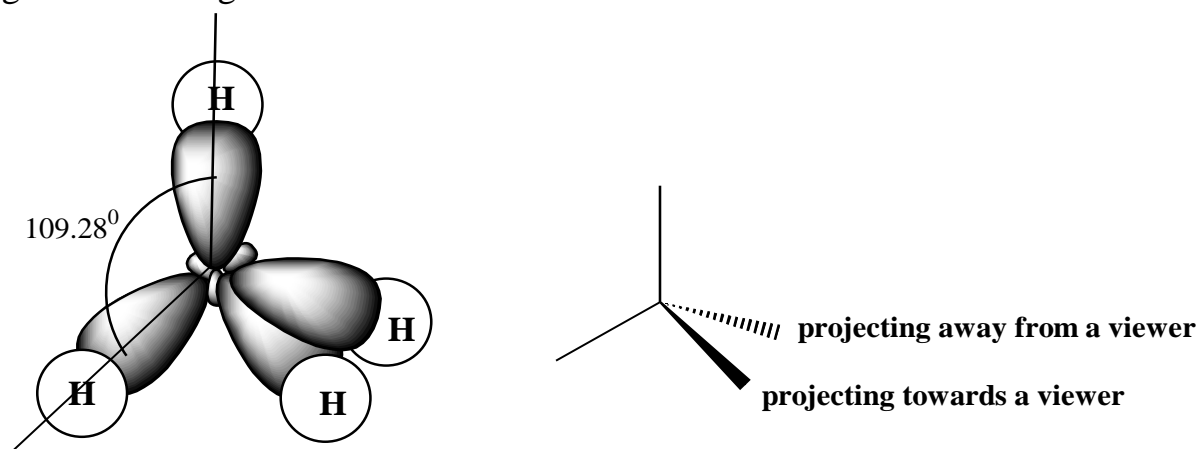

Figure 2.2 — sp^3 -Hybridization of carbon atom and wedge-and-dash representation of methane molecule

Configurational isomers are structures that can be interconverted only by breaking one or more bonds in a molecule (figure 2.3).



Figure 2.3 — A different configuration of a person

Conformations are different shapes of a molecule achieved as the result of carbon atoms rotation about single bonds. Conformers are stereoisomers, which are interconvertible by single bond rotation. Bond rotation allows chains of atoms to adopt a number of conformations (figure 2.4).

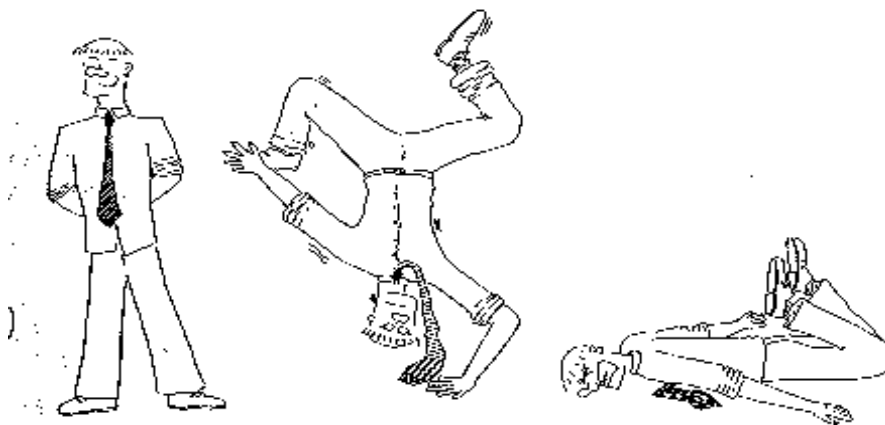

Figure 2.4 — Different configurations of a person
(some being more stable than others)

Structure of conformers is represented by the **Newman projections**. Newman projection shows the two bonded carbon under consideration with one directly in front of the other. In the Newman projection the point represents the front carbon atom; the open circle represents the rear carbon. The bonds connecting the other atoms with the carbons are shown emerging from the point and the circle. There are two main types of conformations: **staggered** and **eclipsed**.

In **the eclipsed conformation** C-H bonds on the front and back carbons are aligned. The angle between hydrogen atoms is zero. In other words, in the eclipsed case the near C-H bond completely blocks the view of the far bonds just as in a solar eclipse the moon blocks the sun as seen from the Earth (figure 2.5).

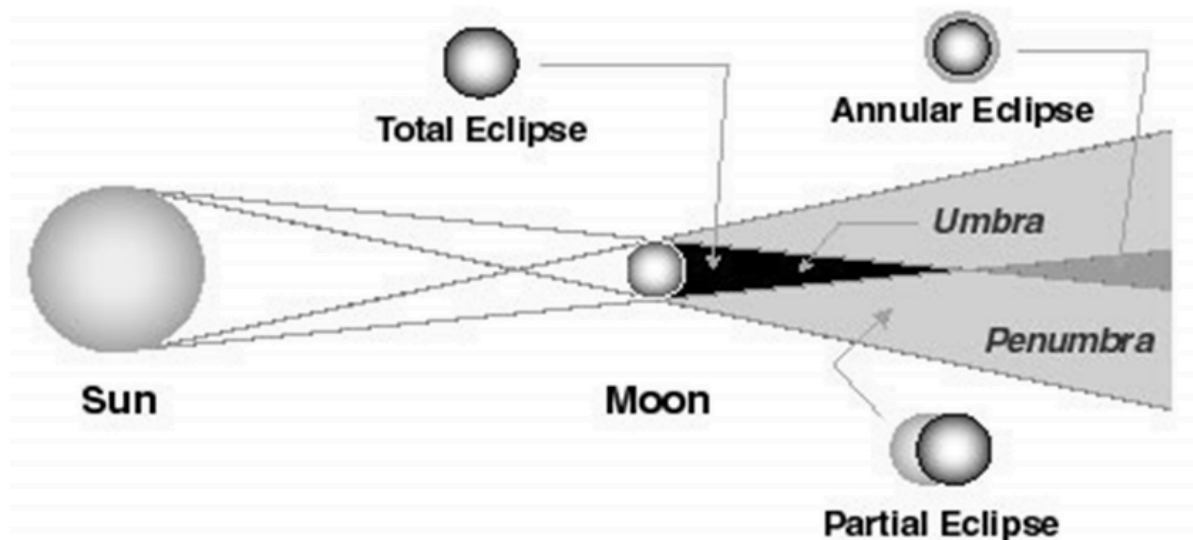

Figure 2.5 — In a solar eclipse the moon blocks the sun as seen from the Earth

By rotating one carbon 60° with respect to the other, we can convert eclipsed conformation into staggered. In the staggered conformation, the far C-H bond appears in the gaps between the near C-H bonds. The angle 60° was assumed as the minimal angle of rotation — **the torsional angle**.

Staggered conformations of molecules with two large substituents fall into two categories: **an anti-form** (a torsional angle between substituents is 180°), and **a gauche-form** (a torsional angle is 60°). In order to find all principle conformations of a molecule we must perform a rotation about a single bond by 360° .

Internal energy of different conformers may differ greatly. Conformers are the most stable with lest energy. The increase in energy is due to some types of strain: a torsion strain and a Van der Waals strain.

Torsion strain is the result of repulsion of nearby electron pairs. It takes place in eclipsed conformations. Van der Waals strain is the result of repulsion between two large radicals or functional groups.

To better understand such concepts as the configuration and conformation of molecules, we'll consider the spatial structure of the ethane molecule. This kind of operation is called **a conformational analysis** of the molecule.

The conformational analysis of the ethane molecule involves several steps.

In step 1 we draw a structural formula of a molecule in order to represent its chemical structure $\text{CH}_3 - \text{CH}_3$.

In step 2 we draw its wedge-and-dash representation in order to reflect a tetrahedron configuration of a molecule

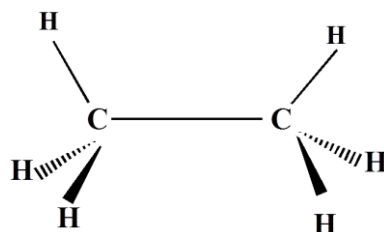

In step 3 we draw the Newman projections for eclipsed and staggered conformation of ethane molecule:

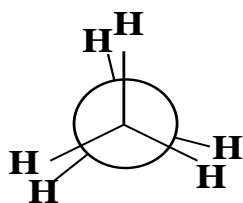

Eclipsed conformation (I)

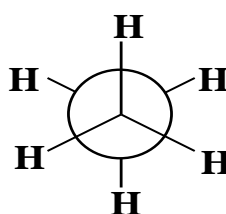

Staggered conformation (II)

A staggered conformation of ethane is more stable than an eclipsed conformation, because the staggered conformation allows for a maximum separation of the electron pairs in the molecular orbitals of the $\text{C} - \text{H}$ bonds. In other words, it is free of torsion strain.

Thus the staggered conformations correspond to the energy minima (E_{min}), and the eclipsed conformations correspond to the energy maxima (E_{max}). Since these energy levels differ from one another only by 12 kJ/mol , an easy transition from one conformation to another occurs. Thus, ethane is an equilibrium mixture of two conformations. Figure 2.6 represents an energy diagram that shows how the internal energy of ethane changes as one of its methyl groups rotates with respect to the other.

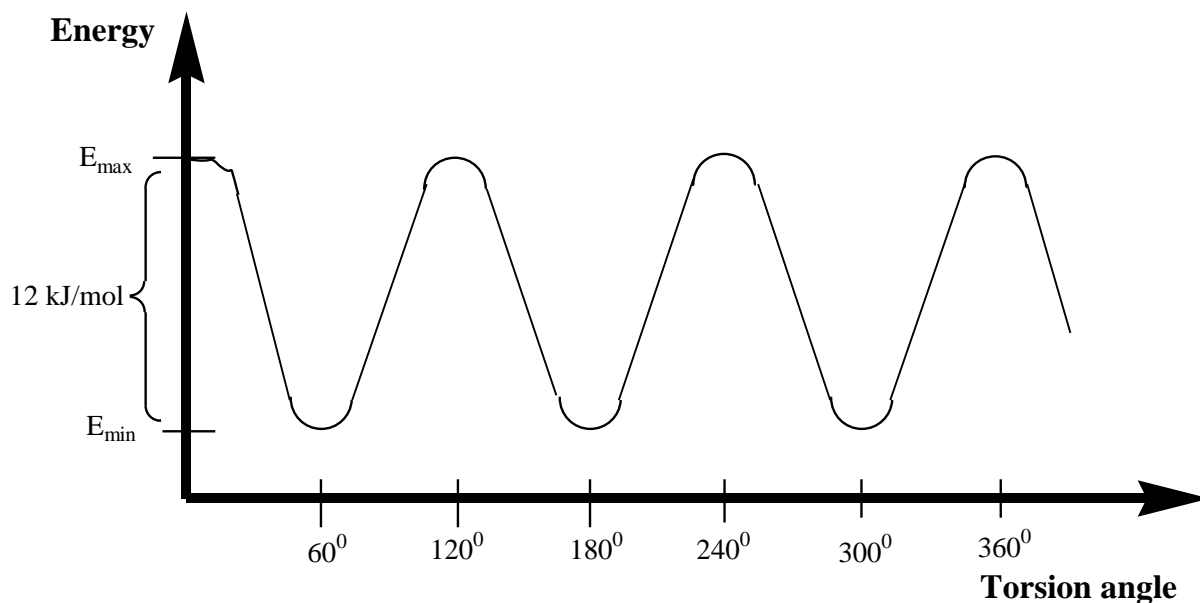
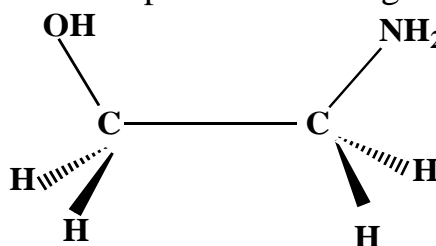
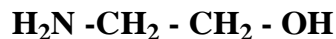
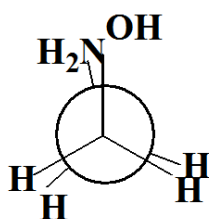

Figure 2.6 — Energy diagram for rotation in ethane.
The rotational barrier E is 12 kJ/mol

The conformational analysis of colamine involves the same steps as ethane analysis. Its structural formula and wedge-and-dash representation are given below:



The gradual rotation of rear carbon about C-C single bond results in formation of four distinct conformations of colamine.



I – Eclipsed – 1

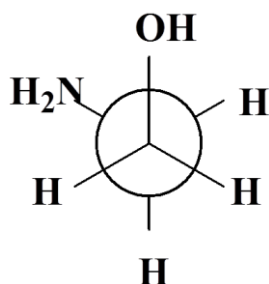

II – Gauche-form

The eclipsed-1 conformation is characterized by maximum energy (E_{max}) since it exhibits both torsion and van der Waals strains. Van der Waals strain appears as the result of amino- and hydroxyl groups repulsion.

This Newman projection represents of colamine molecule gauche-form. The angle between amino- and hydroxyl groups is 60° . The internal energy of a given conformation is less than energy of eclipsed-1 conformation, because it is free of torsion strain but still exhibits van der Waals strain. Let's mark its energy as E_{min} .

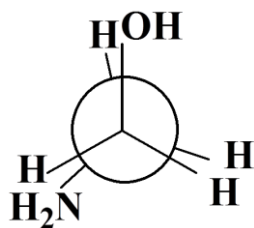

III – Eclipsed – 2

This Newman projection represents the eclipsed–2 conformation of colamine molecule. The angle between amino- and hydroxyl groups is 120° . Its internal energy is less than energy of eclipsed–1 conformation, because it is free of van der Waals strain but it is greater than energy of gauche-form since it exhibits the torsion strain. Let's mark its energy as E'_{\max} . ($E'_{\max} > E_{\max}$)

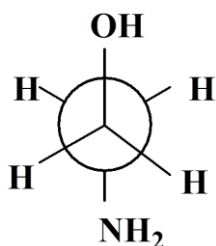

IY – Anti-form

This Newman projection represents the anti-form of colamine molecule. The angle between amino– and hydroxyl groups is 180° . Anti-form is the most stable conformation because it is free of torsion and van der Waals strains. Its energy is E_{\min} . ($E'_{\min} > E_{\max}$).

Figure 2.7 represents an energy diagram that shows how the internal energy of colamine changes as one of its functional group rotates with respect to the other.

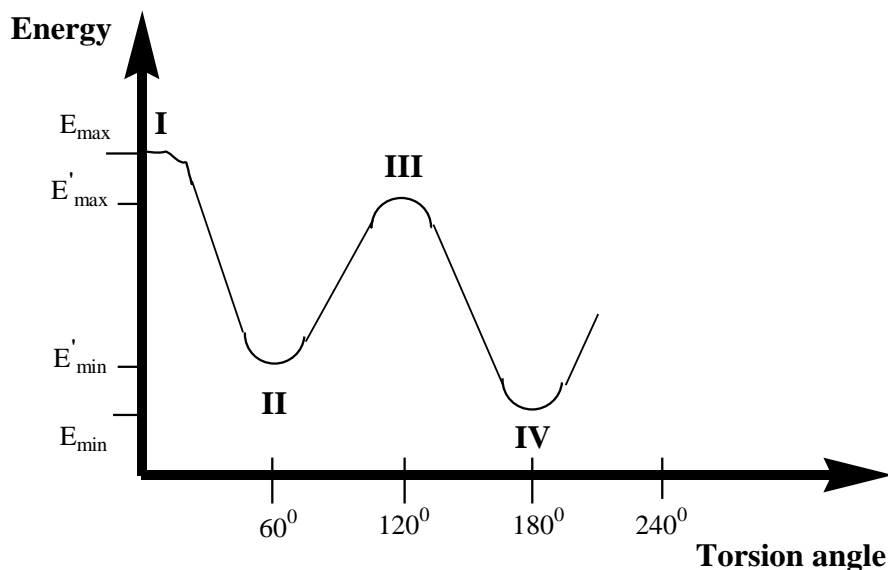
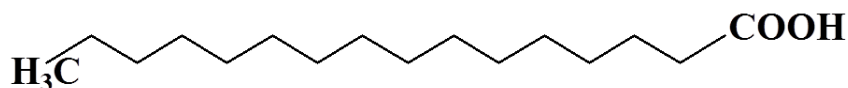

Figure 2.7 — Energy diagram for rotation colamine

When carbon-carbon chain is long, rotations about several single bonds become possible. As the result molecules can adopt a great number of different shapes (conformations). X-ray crystallography method reveals that preferable is zigzag conformation of molecules. A preferable conformation of palmitic acid is



2.4. Conformation of Cyclic Compounds

In 1885 Adolph von Bayer declared that the carbon skeletons of the cycloalkanes were planar. He stated that their stability depends upon angles between covalent bonds: the cyclic stability relates to how closely the C-C-C angles come to 109.5° . If deviation from the tetrahedral value is large cycles are not stable. He called this destabilizing factor an **angle strain**.

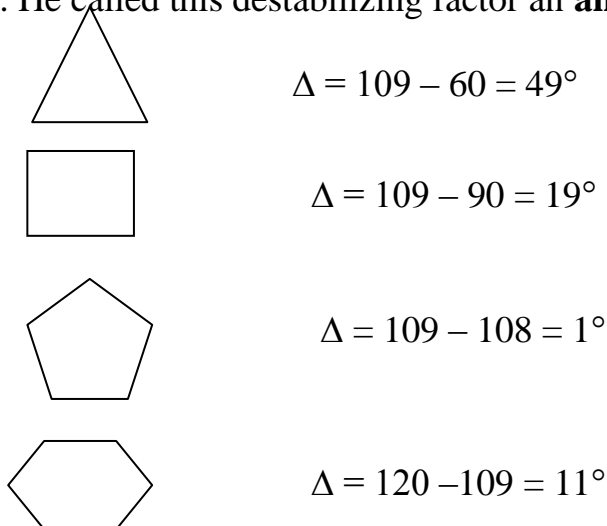

According to Bayer the less strained cycle is cyclopentane but it was proved that cyclohexane is the most stable ring widespread in nature. Six-membered rings have been studied in great details and it was proved that they are not planar and may exist in two conformations: **chair** and **boat** (figure 2.8). Both conformations are free of angle strain because all angles are 109.5° . In 1943 Odd Hassle of the Oslo University established the chair form as the most stable conformation on cyclohexane. Its energy is 35 kJ/mol less than the bath conformation energy.

Thus, the more stable conformation is chair conformation, which is angle and torsions strain free.

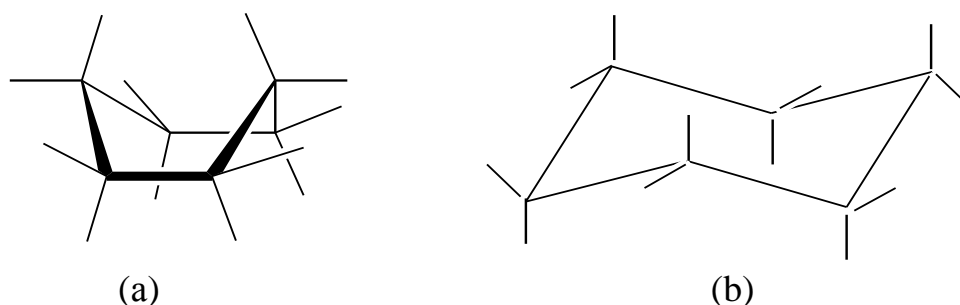

Figure 2.8 — Conformations of cyclohexane (a) boat and (b) chair

In the chair conformation the hydrogen in cyclohexane fall into two sets, called axial and equatorial. Three axial hydrogens lie above and three lie below the average plane of the carbon atoms; the six equatorial hydrogens lie approximately in that plane.

A motion can convert one chair conformation into another chair conformation in which all-axial hydrogens have become equatorial and visa versa (figure 2.9).

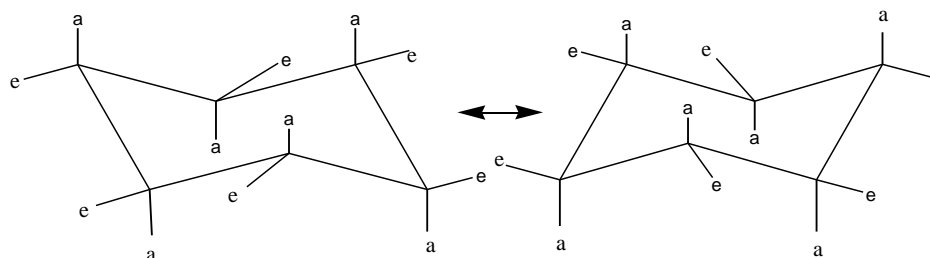

Figure 2.9 — Chair Inversion

A substituent group may be in axial or equatorial position, but equatorial position is preferable (figure 2.10).

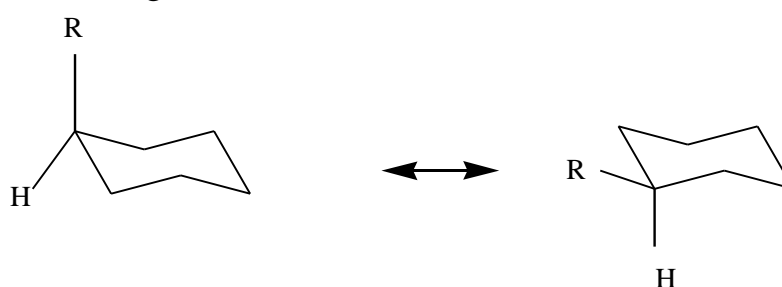

Figure 2.10 — Axial (R) or equatorial (H) positions

The six-membered ring in the chair conformation is a common structural feature of many organic molecules, including sugar molecules like glucose, where one ring carbon is replaced by an oxygen atom (figure 2.11).

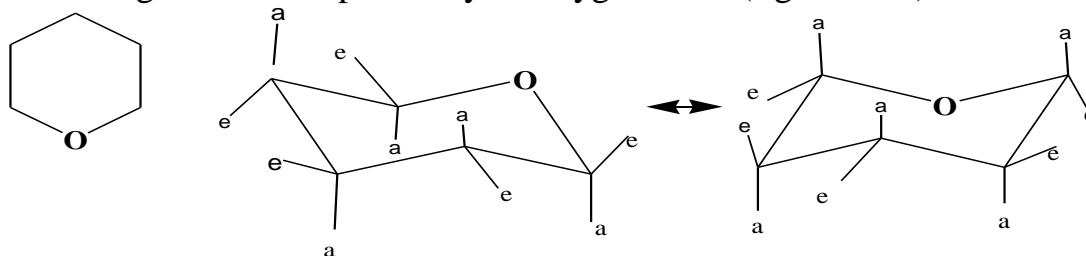

Figure 2.11 — Oxygen contain ring of glucose

2.5. Exercises for the Self-Control

1. Describe chemical structure, configuration and conformations for 1, 2–dibromoethane. Draw an energy diagram for its conformers.
2. Describe chemical structure, configuration and conformations of ethandiol–1, 2. Draw the energy diagram of its conformers.
3. Describe chemical structure, configuration and conformations of 2–aminoethanthiol–1. Draw the energy diagram for its conformers.
4. Describe chemical structure, configuration of a substituted carbon atom and most stable conformation of methyl cyclohexane.
5. Describe chemical structure, configuration of a substituted carbon atom and most stable conformation of 1, 3-dichlorocyclohexane.

CHAPTER 3 CONJUGATED AND AROMATIC SYSTEMS

After reading this chapter, you should be able to:

- define conjugated systems and types of conjugation. Give examples of conjugation in bioactive compounds;
- describe aromatic systems and criteria for aromaticity;
- give classification of aromatic compounds and list their most important properties;
- prove aromaticity of benzoic structures such as naphthalene, anthracene and phenanthrene;
- prove aromaticity of heterocycles such as pyridine and pyrrole;
- prove aromaticity of non-benzoic structures such as cyclopentadienyl anion and cycloheptatrienyl cation;
- define inductive and resonance effects of electron-donating and electron-withdrawing groups in molecules of organic compounds.

3.1. Conjugated Systems

Among unsaturated hydrocarbons and their derivatives conjugated systems are distinguished for their high stability, therefore they are wide spread in nature. **Conjugated systems** are distinguished by having an alternating sequence of single and double bonds. For example, butadiene -1, 3:



Every carbon atom in its molecule is sp^2 -hybridized. Three sp^2 -orbitals lie in a plane and are directed to the corners of an equilateral triangle. An angle between them is 120° . Three valence electrons are placed in the three sp^2 -orbitals. The fourth valence electron is placed in the remaining p_z -orbital, whose axis is perpendicular to the plane formed by the three sp^2 -hybrid orbitals. In butadiene-1, 3 (figure 3.1) each carbon atom contributes one p_z -orbitals to the π -orbital system, which involves four carbon atom nuclei.

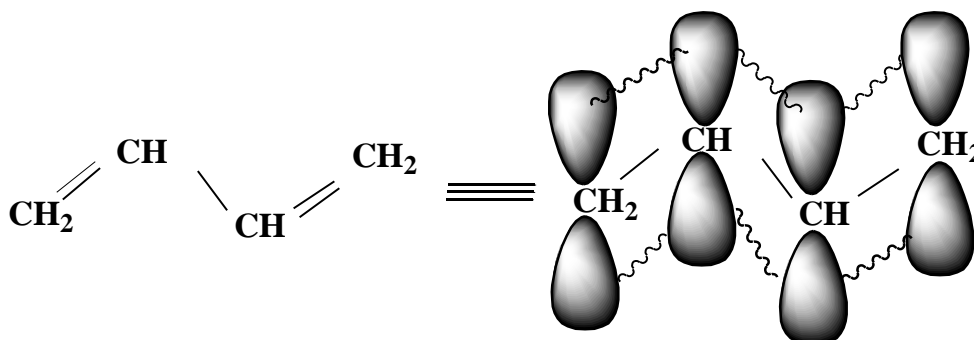
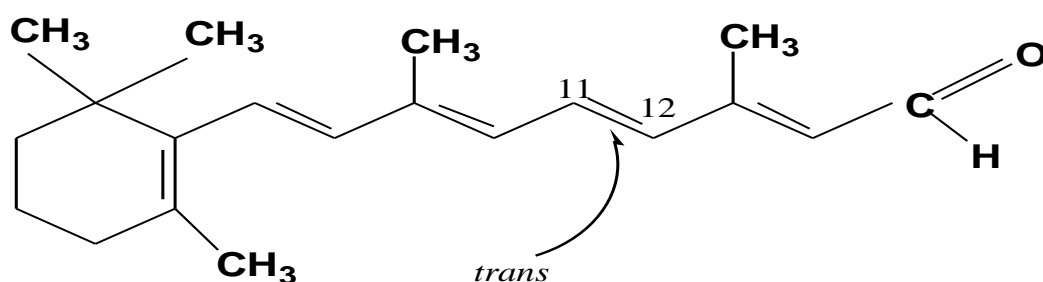
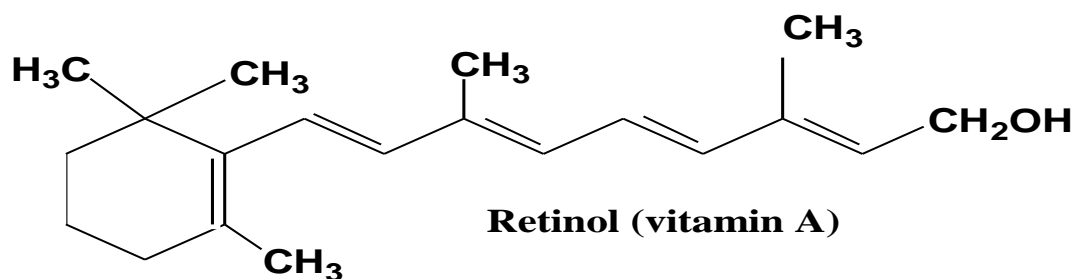
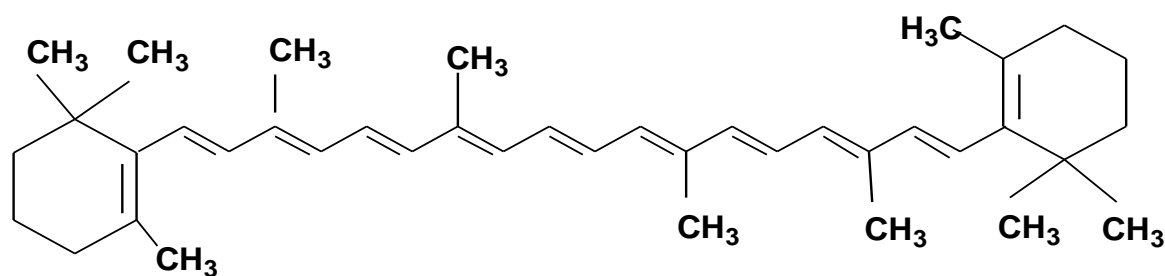

Figure 3.1 — Conjugated system of butadiene-1, 3

The π -bond which molecular orbital involves three or more nuclei is called a **delocalized π -bond**. The formation of an extended π -orbital system leads to equalization of bond length and electric charges and also stabilizes a molecule. The more nuclei are involved in a conjugation the greater is stabilization energy. **Stabilization energy** (E_s) is a difference between energy levels of a conjugated system and an analogue system with isolated π -bonds. The greater is stabilization energy the higher is stability of conjugated systems.

For butadiene-1, 3 stabilization energy is not large (~ 15 kJ/mol), but it is much greater for β -carotene — a yellow-orange pigment found in carrots and many other plants. This hydrocarbon has 11 carbon-carbon double bonds in conjugation. β -Carotene is the biological precursor of the unsaturated alcohol vitamin A (also called retinol) and an unsaturated aldehyde retinal—a key substance involved in vision (figure 3.2).



Retinal (plays a key role in a process of vision)

Figure 3.2 — Conjugated systems in nature

These bioactive substances are stable and wide spread in nature due to conjugation.

The Chemistry of Vision



Color in organic molecules is usually associated with extended conjugated systems of double bonds. A good example is β -carotene, a yellow-orange pigment found in carrots and many other plants. This $C_{40}H_{56}$ hydrocarbon has 11 carbon-carbon bonds in conjugation. It is the biological precursor of the C_{20} unsaturated alcohol vitamin A (also called retinol), which in turn leads to the process involved in vision, 11-*cis*-retinal, that the conversion of vitamin A to 11-*cis*-retinal involves not only oxidation of the alcohol group ($-\text{CH}_2\text{OH}$) to an aldehyde ($-\text{CH}=\text{O}$), but also *trans* \rightarrow *cis* isomerism at the $C_{11} - C_{12}$ double bond. *Cis-trans* isomerism plays a key role in the process of vision.

The rod cells in the retina of the eye contain a red, light-sensitive pigment called rhodopsin. This pigment consists of the protein opsin combined at its active site with 11-*cis*-retinal. When visible light with the appropriate energy is absorbed by rhodopsin, the complexed *cis*-retinal is isomerized to the *trans* isomer. This process is fantastically fast, occurring in only picoseconds (10^{-12} seconds). As you can see from their structures, the shapes of the *cis* and *trans* isomers are very different.

The *trans*-retinal complex with opsin (called metarhodopsin-II) is less stable than the *cis*-retinal complex, and it dissociates into opsin and *trans*-retinal. This change in geometry triggers a response in the rod nerve cells that is transmitted to the brain and perceived as vision.

If this were all that happened, we would be able to see for only a few moments, because all of the 11-*cis*-retinal present in the rod cells would be quickly consumed. Fortunately, the enzyme *retinal isomerase*, in the presence of light, converts the *trans*-retinal back to the 11-*cis*-isomer, so that the cycle can be repeated. Calcium ions in the cell and its membrane control how fast the visual system recovers after exposure to light. They also mediate the way in which cells adapt to various light levels. The following sequence summarizes the visual cycle:

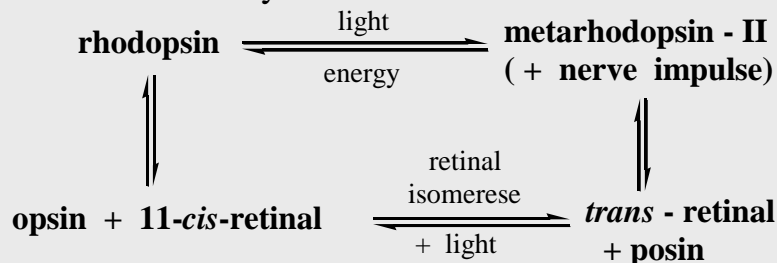

This representation is simplified because there are actually several additional intermediates between rhodopsin and the fully dissociated *trans*-retinal and opsin. In the liver, β -carotene is converted into vitamin A first and then into 11-*cis*-retinal.

There are two types of conjugation. π , π -Conjugation takes place, when there is alternating sequence of single and double bonds in a molecule. For example, butadiene-1, 3, which structure was discussed beforehand:

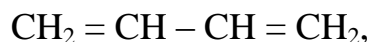

and hexatriene-1,3,5:

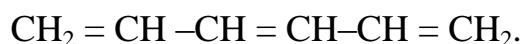

π , p -Conjugation occurs when π -bond is located nearby an atom containing a non hybridized p -orbital with a lone electron pair. For example, vinyl chloride



or divinyl ether

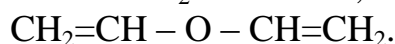

3.2. Aromatic Systems

The most stable are cyclic conjugated systems known as aromatic substances. The discussion of aromaticity is best started by outlining the discovery of benzene and its properties. In 1825 M. Faraday pyrolyzed whale oil and obtained a colorless liquid with empirical formula C_6H_6 . The substance was named benzene.

In 1865 Kekulé suggested that benzene was two rapidly equilibrating cyclohexatriene isomers. Benzene has been shown to be planar, with all the C-C bonds of equal distance, resists normal reactions of alkenes, and is much more thermodynamically stable than expected.

Later it was proved that benzene is a π , π -conjugated system with a delocalized π -bond (figure 3.3).

Friedrich August Kekulé (7 September 1829 — 13 July 1896) was a German organic chemist. From the 1850s until his death, Kekulé was one of the most prominent chemists in Europe, especially in theoretical chemistry. He was the principal founder of the theory of chemical structure.



The π -orbital electronic structure of benzene is orbital overlap

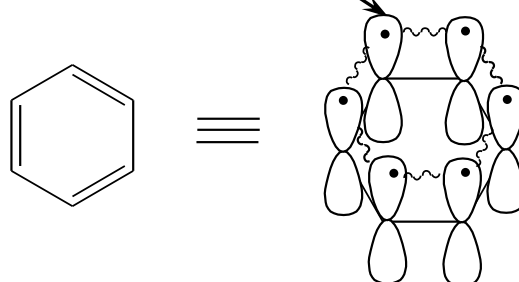
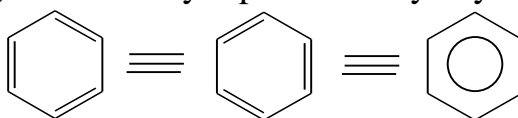

Figure 3.3 — π , π - Conjugated system of benzene

Benzene can be diagrammatically represented by any of the following:



The electron density of a delocalized π -bond is equally distributed along the whole cyclic system. Its maximum density is above and below the cycle. Stability of benzene that arises due to this type of electron delocalization is ~ 120 kJ/mol and is known as aromatic stabilization.

Systems other than benzene may also be aromatic systems. All aromatic systems must satisfy the following **criteria for aromaticity**. They must be:

- (1) cyclic and planar due to sp^2 -hybridization of all atoms in a cycle;
- (2) containing a continuous orbital overlap;
- (3) having $4n+2$ π -electrons involved in a delocalized π -bond (Huckel's rule), where n equals to 0, 1, 2, 3, 4.

Aromatic compounds exhibit the following general properties:

- high boiling liquids or solids Insoluble in water, soluble in organics;
- highly hydrophobic;
- not acid or basic. (pK_a approximately 37);
- more stable than expected for a system having multiple bonds;
- usually behaves as an electron source during chemical reactions;
- undergoes substitution rather than addition reactions;
- their chemistry depends critically on the substituent present on the aromatic system. Unsubstituted systems are not metabolized well, many are carcinogenic. Unsubstituted aromatic systems occur infrequent in natural systems;
- substituted aromatics and heteroaromatic compounds are very common in natural products and bioactive substances.

There are three types of aromatic compounds: (a) benzoic (naphthalene, anthracene, and phenanthrene); (b) non-benzoic (cyclopentadienyl anion, cycloheptatrienyl cation) and (c) heteroaromatic (pyridine, pyrrole, imidazole and others).

The following fused systems such as naphthalene, anthracene and phenanthrene, are benzene derivatives thus they are defined as benzoic structures. They obey all criteria for aromaticity and exhibit all properties, typical for

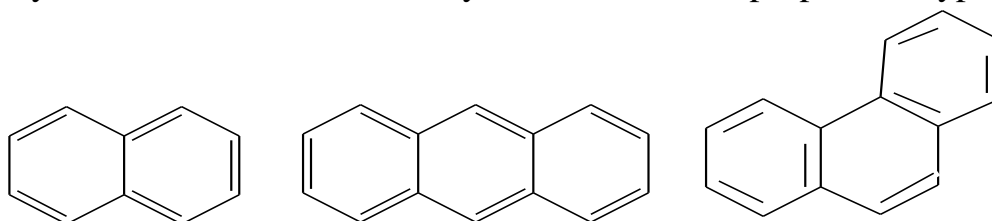

arenes:

Naphthalene

Anthracene

Phenanthrene

$$4n+2=10 \pi\text{-electrons}$$
$$n = 2$$

$$4n+2=14 \pi\text{-electrons}$$
$$n = 3$$

$$4n+2=14 \pi\text{-electrons}$$
$$n = 3$$



Polycyclic Aromatic Hydrocarbons and Cancer

Certain polycyclic aromatic hydrocarbons are carcinogenic (that is, they produce cancers). They can produce a tumor on mice in a short time when only trace amounts are painted on the skin. These carcinogenic hydrocarbons are present not only in coal tar but also in soot and tobacco smoke and can be formed in barbecuing meat. Their biological effect was noted as long ago as 1775 when soot was identified as the cause of the high incidence of scrotal cancer in chimney sweeps. A similar occurrence of lung and lip cancer is common in habitual smokers.

The way these carcinogens produce cancer is now fairly well understood. To eliminate hydrocarbons, the body usually oxidizes them to render them more water soluble, so that they can be excreted. The metabolic oxidation products seem to be the real culprits in causing cancer. For example, one of the most potent carcinogens of this type is benzo[a]pyrene. Enzymatic oxidation converts it to the diol-epoxide shown below. The diol-epoxide reacts with cellular DNA, causing mutations that eventually prevent the cells from reproducing normally.

Benzene itself is quite toxic to humans and can cause severe liver damage, but toluene, although not harmless, is much less toxic. How can this different behavior of two very similar compounds be possible? To eliminate benzene from the body, the aromatic ring must be oxidized, and intermediates in this oxidation are damaging. However, the methyl side chain of toluene can be oxidized to give benzoic acid, which can be excreted. None of the intermediates in this process causes health problems.

Although some chemicals may cause cancer, others can help prevent or cure it. Many substances inhibit cancer growth, and the study of cancer chemotherapy has contributed substantially to human health.

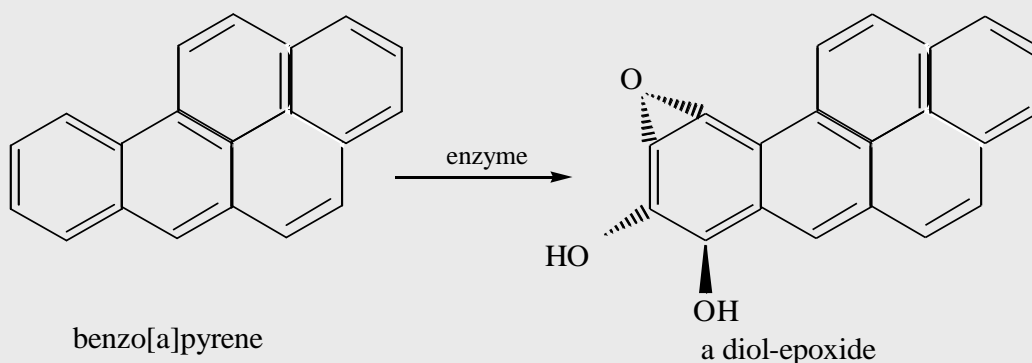

Pyridine is an aromatic heterocycle which can be directly related to benzene; i.e. replacement of a CH by a heteroatom (figure 3.4).

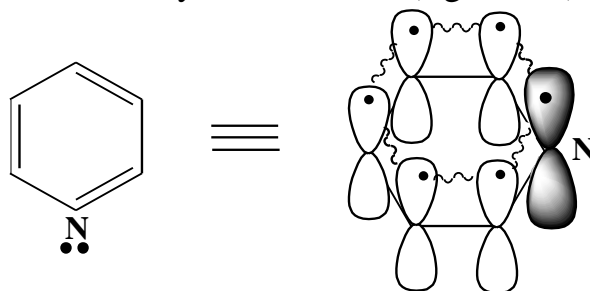

Figure 3.4 — π , π -Conjugated system of pyridine

Pyridine displays the properties expected for an aromatic compound. Its aromaticity becomes clear after revising an electron structure of nitrogen atom in its molecule (figure 3.5). Two sp^2 -hybridized orbitals contain one electron, and one – a lone electron pair. p_z -Orbital is filled with only one electron which is contributed into a delocalized π -bond.

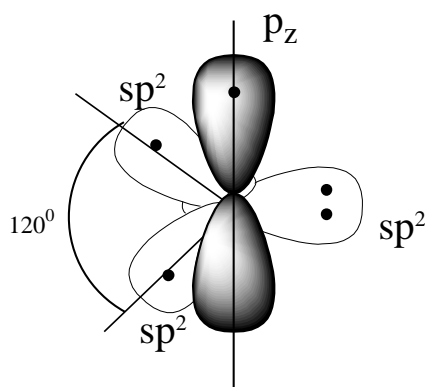

Figure 3.5 — Electron structure of pyridine nitrogen

Pyridine satisfies the criteria for aromaticity. It is a cyclic and planar π , π -conjugated system which an expanded π -bond contains 6 electrons. Thus the Huckel's rule is fulfilled: $4n + 2 = 6\pi$ electrons, where $n = 1$.

Nitrogen's lone-pair does not participate in the aromatic sextet and therefore is similar to other amine lone-pairs (basic, nucleophilic). Nitrogen atom which electronegativity is higher than that of carbon shifts electron sextet towards itself, thus reducing electron density of a ring. Pyridine and similar structures are defined as **π -insufficient systems**. Their electron density is lower than that of benzene. Pyridine cycle is a compartment of NAD, vitamin B₆ and vitamin PP. It's also contained in a great number of medicines.

Pyrrole is a five-membered heterocyclic compound widely occurred in nature. It displays the properties expected for an aromatic compound. Its aromaticity becomes clear after revising an electron structure of nitrogen atom in its molecule (figure 3.6). Three sp^2 -hybridized orbitals contain one electron, and p_z -orbital is filled with a lone electron pair which is contributed into a delocalized π -bond.

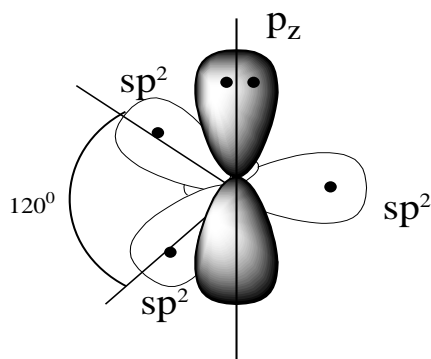

Figure 3.6 — Electron structure of pyrrole nitrogen

Pyrrole satisfies all criteria for aromaticity. It is a cyclic and planar p, π -conjugated system which an expanded π -bond contains 6 electrons. Thus the Huckel's rule is fulfilled: $4n + 2 = 6\pi$ electrons, where $n = 1$ (figure 3.7).

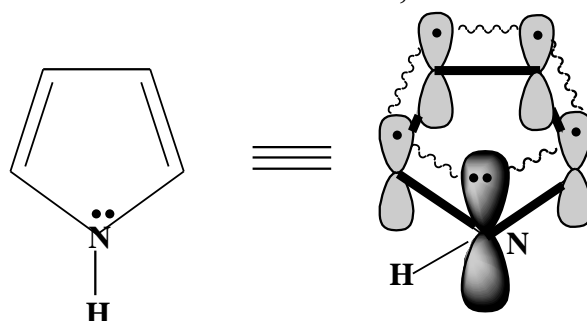
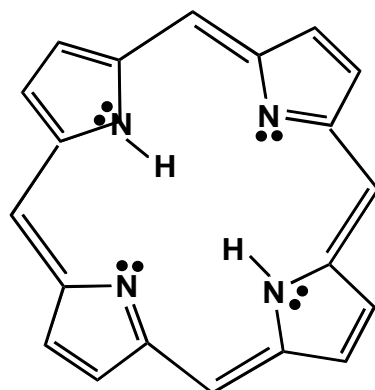

Figure 3.7 — p, π -Conjugated system of pyrrole

Pyrrole is a **super-aromatic system** because a number of electrons involved in conjugation exceed a number of nuclei. Electron density of its ring is higher than electron density of a benzene ring.

Pyrrole ring is a compartment of porphine, the most important component of hemoglobin, cytochromes and chlorophyll. Porphine is a conjugated system which involves four pyrrole cycles and 26 π -electrons. Its stabilization energy is about 840 kJ/mol.



Huckel's $4n+2$ π -electrons can be achieved not only in pyrrole but also in some other five-membered heterocycles. To achieve this, the heteroatom contributes its 'lone-pair' to the aromatic system (figure 3.8). These systems are all reasonable stable and well known.

These systems have a lone-pair in the aromatic sextet

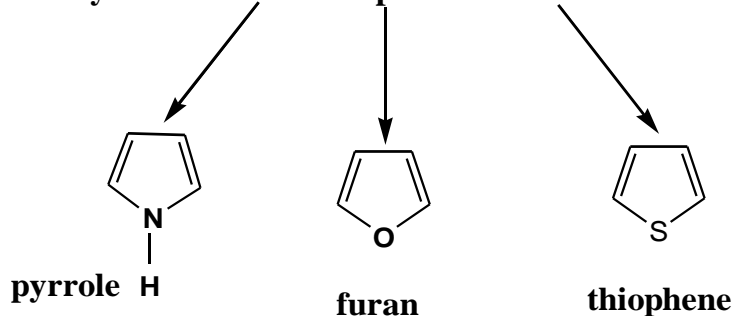
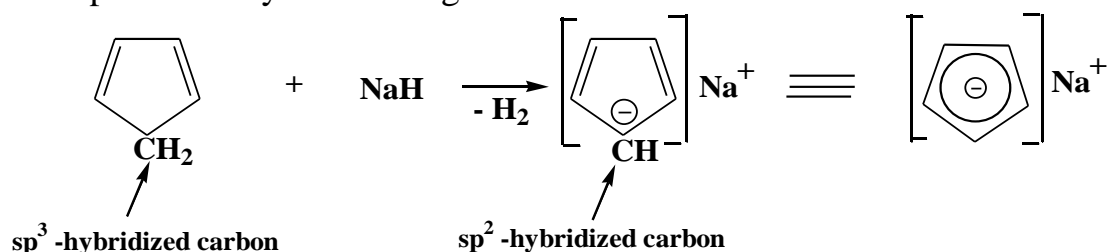

Figure 3.8 — Super Heteroaromatic systems with five-membered cycles

Cyclopentadienyl anion and **cycloheptatrienyl cation** are bright examples of non-benzoic aromatic structures. The formation of cyclopentadienyl anion can be represented by a following scheme:



This cyclic anion satisfies all the criteria for aromaticity (figure 3.8).

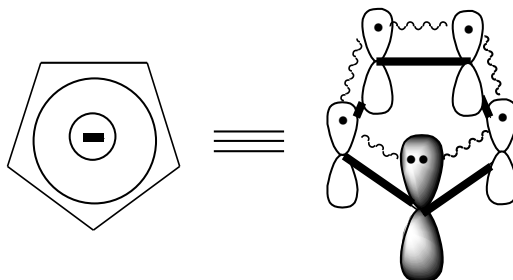

Figure 3.8 — p, π -Conjugated system of cyclopentadienyl

Cyclopentadienyl anion is an aromatic compound, because it is cyclic and planar π, p -conjugated system. Four sp^2 -hybridized carbon atoms contribute one electron into conjugation while negatively charged carbon gives two electrons into the formation of an expanded electron system. Thus the Huckel's rule is fulfilled: $4n+2 = 6\pi$ electrons, where $n = 1$.



Cyclopentadienyl anion is a compartment of ferrocene, applied in medicine to treat iron deficiency.

This medicine exhibits a sandwich — like structure; it is involved into a process of blood formation.

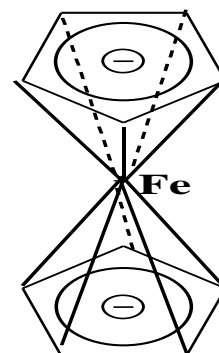

Formation of **cycloheptatrienyl cation** can be represented by a scheme:

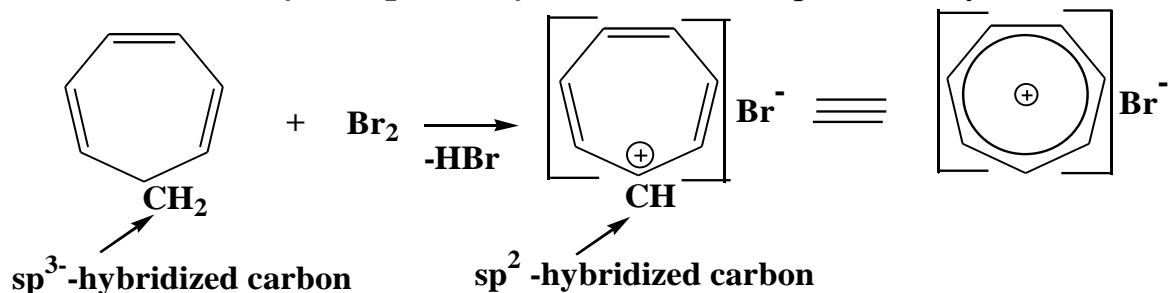

Six sp^2 -hybridized carbon atoms contribute one electron into conjugation while positively charged carbon gives no electrons into the formation of an expanded π -electron system. This system satisfies the criteria for aromaticity (figure 3.9).

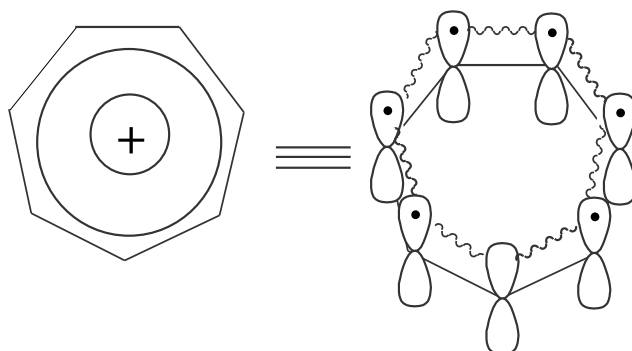

Figure 3.9 — π -Conjugated system of cycloheptatrienyl cation

Cycloheptatrienyl cation is an aromatic system, because it is cyclic planar π , p-conjugated system that contains 6 electrons in a continuous orbital overlap. Thus $4n+2 = 6\pi$ electrons, where $n= 1$ (the Huckel's rule is fulfilled).



Cyclopentadienyl anion and cycloheptatrienyl cation are fused in a molecule of a bioactive substance azulene.

Two terpenoids, vetivazulene (4,8-dimethyl-2-isopropylazulene) and guaiazulene (1,4-dimethyl-7-isopropylazulene), that feature the azulene skeleton are found in nature as constituents of pigments in mushrooms, guaiac wood oil, and some marine invertebrates.

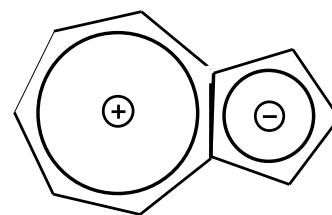

3.3. Inductive and Resonance Effects

The mutual influence of atoms in molecules can be explained by a theory of electrons' shifting. There are two type of electron's shifting in molecules: inductive and resonance effects.

Inductive effect (I) is a transmission charge effect of a substituent by electrostatic introduction through the systems of σ -bonds. This is simply effect of electronegativity as it is attenuated through 3–4 σ -bonds. Inductive effect may be positive (+I) or negative (–I) and substituents can be inductively **donating** or **withdrawing**.

Alkyl radicals (CH_3- , C_2H_5- , C_3H_7- and other) are electron donating substituents which exhibit positive inductive effect. They increase electron density of chains. These groups are donating substituents (+I).

Electron withdrawing substituents (–I) are those groups containing electro-negative atoms: Hal ($\text{Cl}-$, $\text{Br}-$ and other), $-\text{NO}_2$, $-\text{NH}_2$, $-\text{COOH}$, $-\text{OR}$, $-\text{SR}$, $-\text{SH}$. These groups decrease electron density of molecules.

For example, chlorine atom is a substituent in 1-chlorobutane molecule. It exhibits negative inductive effect, which is represented by a system of straight arrows. This effect disappears rapidly after 3 – 4 bonds:

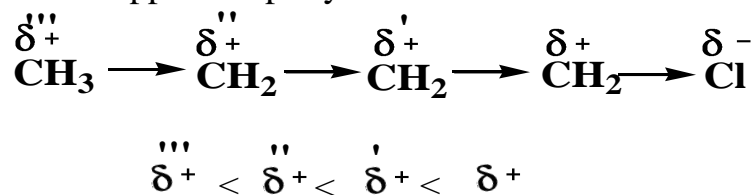

Resonance effect (R) is distributed from a substituent to chain only in a conjugated system. A substituent ought to be a part of a conjugated system. This effect is represented by a system of curved arrows. Resonance effect is stronger than inductive since it does not disappear along the whole conjugated system.

Electron donating substituents (+R) are groups which contain lone electron pairs: $-\text{OH}$, $-\text{OR}$, $-\text{SH}$, $-\text{NH}_2$, $-\text{Hal}$. They contribute these electron pairs into conjugation thus increasing electron density of a chain.

Electron withdrawing substituents (–R) are groups which contain double bonds: $-\text{NO}_2$, $-\text{SO}_3\text{H}$, $-\text{COOH}$, $-\text{CHO}$. They attract electrons toward themselves thus decreasing electron density of a chain.

The signs of inductive and resonance effects of radicals and functional groups are given in Appendix 3. To better understand the mechanism of the inductive and resonance effects of substituents on the distribution of electron density in the molecules of organic compounds, we'll consider a few examples.

Example. Represent inductive and resonance effects of substituents in propenal and methyl vinyl ether molecules.

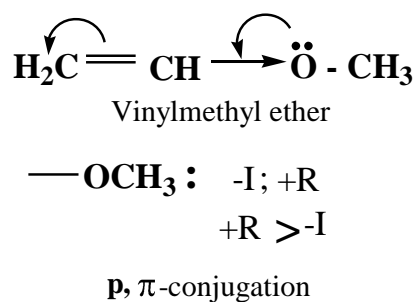
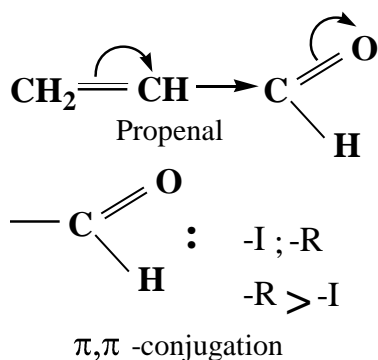

Example. Represent inductive and resonance effects of substituents in para-amino benzoic acid molecule:

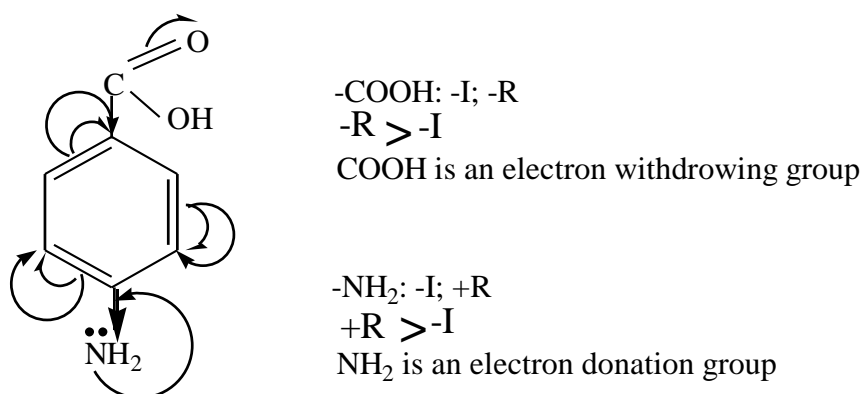

Electronic effects of the substituents are an important factor that allows a qualitative estimate of the distribution of electron density in the molecule, and to predict its chemical properties. Each atom that carries a partial electric charge is able to behave as a reactionary center in a molecule.

3.4. Exercises for the Self-Control

1. What type of conjugation (π , π - or p , π -) takes place in isoprene (2-methyl-butadiene-1, 3) molecule?
2. Write a structural formula of azulene and prove its aromaticity.
3. Give the structural formula for imidazole. Describe electron structures of pyridine and pyrrole nitrogen atoms. Prove aromaticity for imidazole.
4. Represent inductive and resonance effects of substituents in the following molecules:

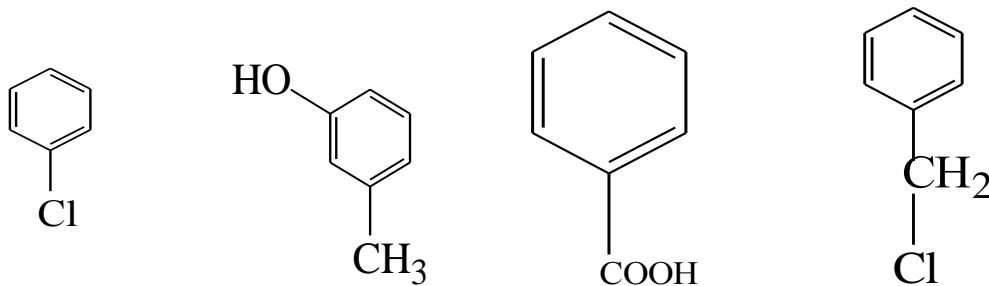

CHAPTER 4

CLASSIFICATION AND MECHANISM OF ORGANIC REACTIONS

After reading this chapter, you should be able to:

- give classification to chemical reactions in organic chemistry;
- know the descriptive terminology that applies to organic reactions;
- understand the relationship between a reaction profile and a reaction mechanism;
- recognize when a reaction is substitution, elimination, or addition;
- describe electrophilic and nucleophilic reagents;
- define most important intermediates (carbocations, carbanions and radicals).

4.1. Organic Reaction Terminology

A typical chemical reaction requires a set of **reagents** or **starting materials**. Organic chemists are mostly interested in those reagents that contain carbon. They call them substrates. **A substrate is a reacting molecule, which gives its carbon atom to form a new chemical bond.**

Products are the substances that result from the reaction of the substrate with other reagents. There are two categories of products: the product of interest and the **by-product**. The product of interest is the compound formed from the substrate. The by-products are any other products and are often of little interest to practicing organic chemists.

Chemical reaction and chemical synthesis are the «really interesting stuff that organic chemistry is all about». But before you get to those things, you need to review some material from chemical thermodynamics and chemical kinetics.

From the point of view of chemical thermodynamics the driving force of chemical reactions is the tendency to the formation of new substances with a lower free energy and greater stability. From the point of view of chemical kinetics most reactions in organic chemistry involve several elementary steps and run through several transition states and several intermediates.

An elementary step is a collision of reagents' particles which produce molecules of a product. A sequence of elementary steps that leads to product formation is defined as a **reaction mechanism**.

A transition state (also defined as an activated complex) is an energetically excited state that is intermediate between reagents and products in a chemical reaction. The structure of the transition state is important, because it shows how the molecules are interacting. A formula of a transition state is generally written within brackets to underline instability of a given particle. In a transition state the chemical bonds in a reagent's molecule are not broken yet, and the new bonds are not formed yet. In order to reflect the statement that bonds are in the process of breaking and formation, they are represented by dotted lines. For ex-

ample, in the reaction of chloro acetic acid with hydroxide anion, the transition state involves the formation of a bond between the OH and C, as the bond breaks between Cl and C:

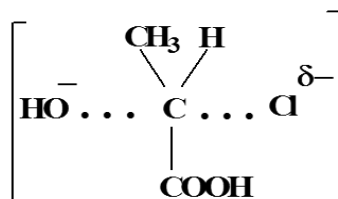

We can follow the changes in energy as the reaction progresses with the help of potential energy profiles. A typical energy profile for stepwise reaction is represented in figure 4.1.

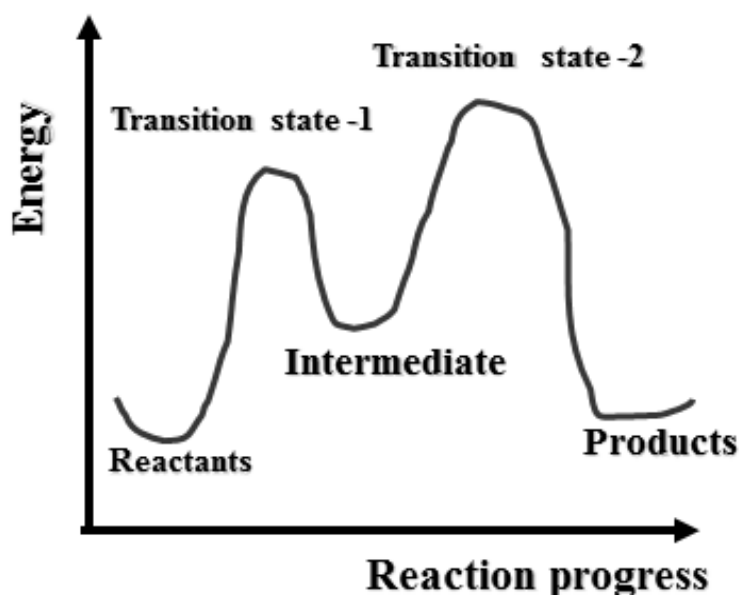

Figure 4.1 — Potential energy profile for stepwise reactions

The points on the curve, corresponding to the highest energy levels represent the transition states of the reaction. The reaction profile includes a **reaction intermediate** between two transition states. Some intermediates are sufficiently stable to be isolated and examined; others are so reactive that chemists can only infer their existence through cleverly designed experiments.

The most important intermediates are:

- (1) **carbocations** — particles, which contain positively, charged carbon atoms;
- (2) **carbanions** — particles, which contain negatively, charged carbon atoms;
- (3) **radicals** — particles, which contain unpaired electrons. Most radicals are extremely reactive.

Carbocations are classified according to the type of carbon atom that carries positive electric charge. There are:

- primary carbocations, e. g. CH_3^+ , C_2H_5^+ ;
- secondary carbocations, e. g. $(\text{CH}_3)_2\text{CH}^+$;
- tertiary carbocations, e. g. $(\text{CH}_3)_3\text{C}^+$.

The stability of carbocations alters in a following series (figure 4.2):

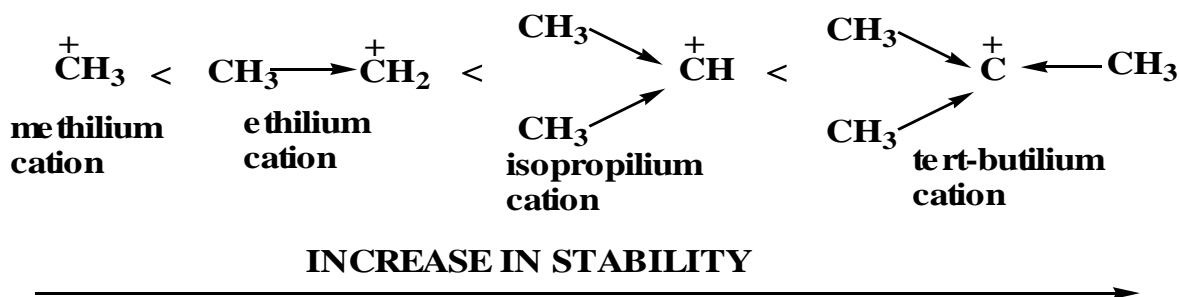

Figure 4.2 — Stability of carbocations

Delocalization of electric charge is the reason for stability of carbocations. The rate of chemical reactions depends upon intermediate's stability.

Carbanions are alkyl or aryl groups with a negatively charged carbon atom. The greater is delocalization of their negative charge the greater is stability. The most stable are aromatic carbanions, for example, cyclopentadienyl anion:



Estimating the differences in the energy levels of reagents, intermediates, transition states and products can help you roughly predict the rate of a reaction.

The rule is that the less stable the transition state, the higher its energy and the slower its rate of a reaction. This rule is important because the highest energy level on a reaction profile indicates the overall reaction rate for that reaction. The step of the reaction involving the highest-energy transition state is the **rate-determining step**.

4.2. Classification of Reagents Involved into the Chemical Reactions

The reagents in organic reactions fall into two categories: electrophilic and nucleophilic particles.

Electrophilic reagents or **electrophiles** are electron-poor reagents or electron pair acceptors. Electrophilic reagents are:

(a) molecules, which contain vacant orbitals, such as SO_3 , AlCl_3 , SnCl_4 , FeBr_3 , BF_3 (they are defined as Lewis acids);

(b) cations, for example, protons (H^+), ions of metals (Met^+), SO_3H^+ , NO_2^+ , NO^+ ;

(c) molecules with low electron density of atoms, for example, halogenated compounds $\text{R}^{\delta+}\text{---Hal}^{\delta-}$, halogens (Cl_2 , Br_2 , I_2), and carbonyl compounds:

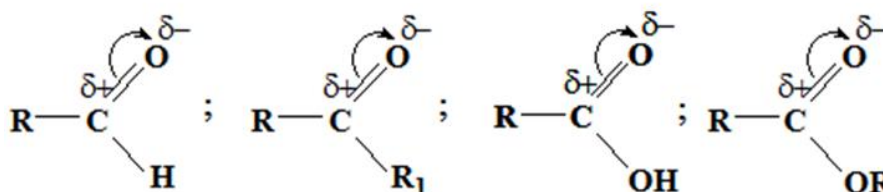

Nucleophilic reagents or nucleophiles are electron-rich reactants or electron pair donors. They are:

(a) molecules with lone electron pairs:

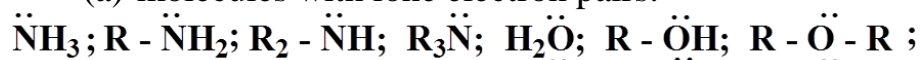

(b) anions: OH^- ; CN^- ; NH_2^- ; RCOO^- ; RS^- ; Cl^- ; Br^- ; I^- ; HSO_3^- ;

(c) compounds with multiple bonds, for example,

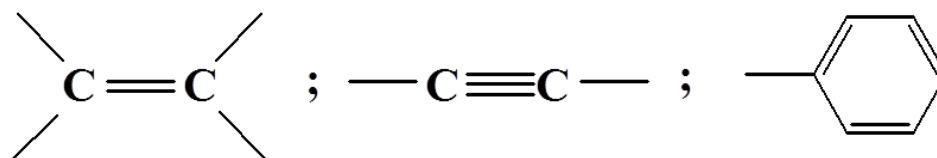

Electrophiles (E) tend to react with electron-rich regions of substrate molecules. Nucleophiles (Nu) tend to react with electron-deficient centers in the substrate molecules:

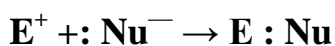

4.3. Classification of Chemical Reactions in organic chemistry

Organic reactions are classified in several ways.

According to their direction there are three types of processes:

- substitution (S);
- addition (A);
- elimination (E).

In a **substitution reaction**, an incoming atom or a group of atoms replaces a leaving atom or a group of atoms. For example, chlorine atom displaces hydrogen atom in the benzene ring in the reaction of benzene chlorination:

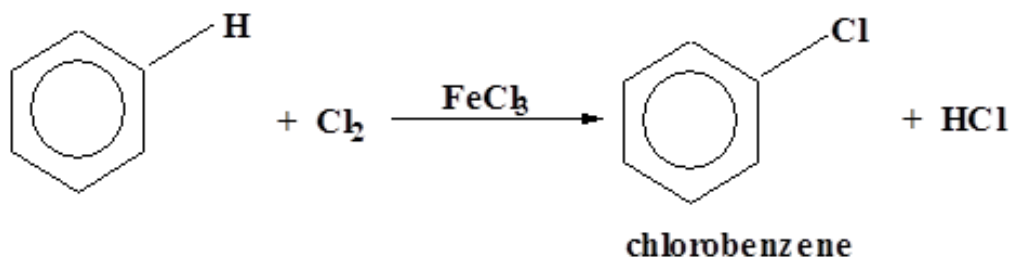

In an **addition reaction**, pairs of atoms or groups of atoms add to a multiple bond. For example, hydrogen atoms add to carbon atoms in the reaction of an alkene hydrogenation:

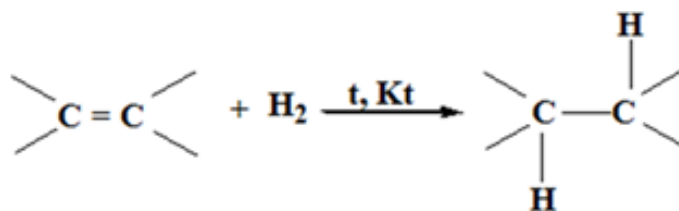

In an **elimination reaction**, a pair of atoms or a group of atoms leaves the substrate. The substrate then forms a multiple bond or forms a cyclic structure. For example, acid catalyzed dehydration of isopropyl alcohol is bright example of such reactions:

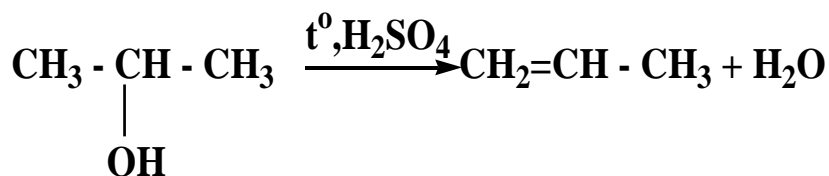

According to the type of bonds' cleavage and bonds' formation there are **heterolytic** and **homolytic reactions**.

Heterolysis (from Greek different) it's a bond cleavage where one of the two atoms involved leaves with both of the bonding electrons. Homolysis (from Greek «same») is a bond cleavage where one of the two atoms involved leaves with one of the bonding electrons (figure 4.3).

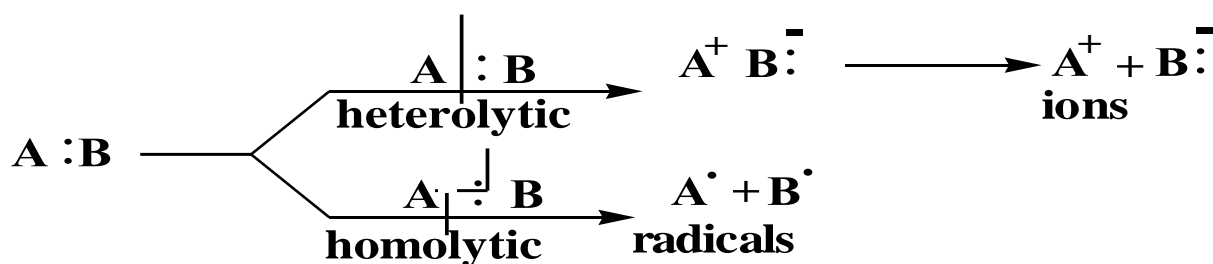

Figure 4.3 — Types of bonds' cleavage

The products of heterolysis are ions, that is why heterolytic reactions are defined as **ionic reactions**. Ionic reactions involve ions as intermediates.

The products of homolysis are **radicals**, which may be atoms or molecules, and contain an unpaired electron. Homolytic chemical reactions, involving formation of radicals, are **radical or chain reactions**.

According to **molecularity of rate — determining step** the reactions are:

- monomolecular — involve only one particle;
- bimolecular — involve two particles;
- termolecular — involve three particles.

Molecularity can't exceed three since probability of four particles collision is negligibly low.

4.4. Exercises for the Self-Control

1. Classify each of the following reactions as substitution, addition, or elimination.

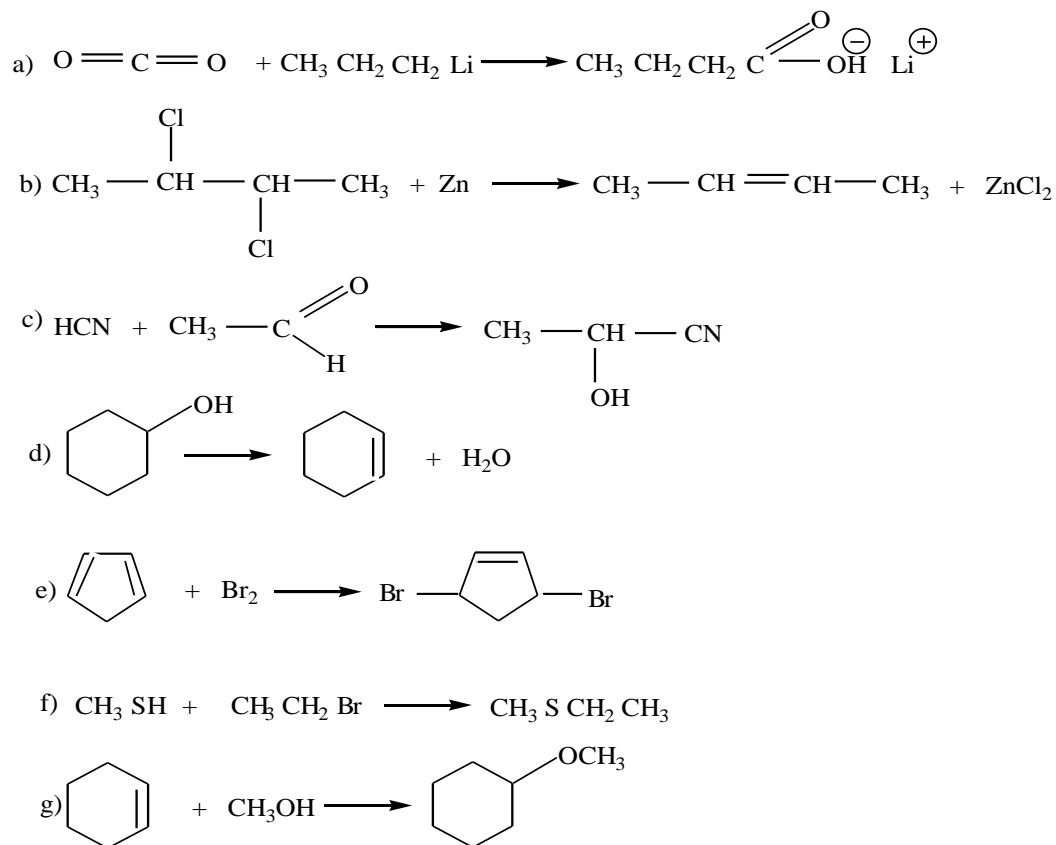

2. Each of these molecules is nucleophilic. Identify the nucleophilic center in them.

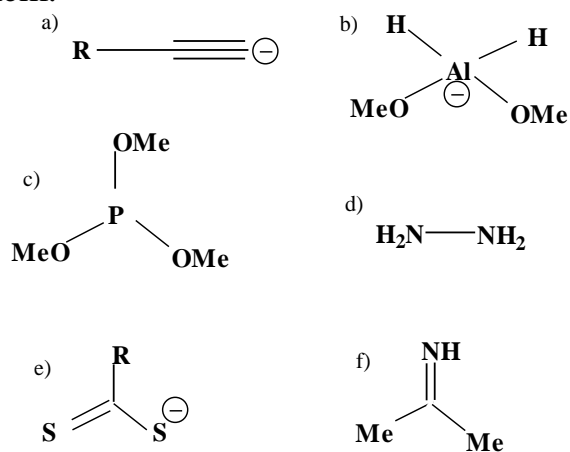

3. Each of these molecules is electrophilic. Identify the electrophilic center in them.

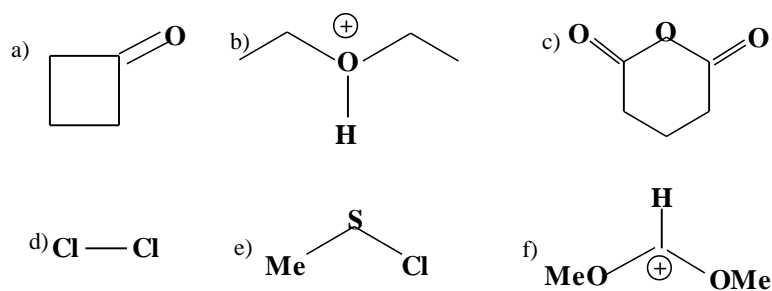

CHAPTER 5

ACIDITY AND BASICITY OF ORGANIC COMPOUNDS

After reading this chapter, you should be able to:

- define acids and bases according to Bronsted theory;
- give classification for acids according to the origin of acidic centers in their molecules;
 - characterize acidity of organic substances according to stability of conjugate bases;
 - describe the ways to increase stability of conjugate bases and enhance acidity of organic molecules;
 - discuss classification of organic bases and factors which effect their basicity;
 - define the methods to compare basicity of substrates;
 - describe acid-base duality of organic compounds and its biological role *in vivo*.

5.1 Acidity and Basicity Rewired

Originally a substance was identified as an acid if it exhibited the properties shown by other acids: a sour taste (the word acid is derived from the Latin *acidus* meaning "sour") and the abilities to turn blue vegetable dyes red, to dissolve chalk with the evolution of gas, and to react with certain "bases" to form salts. It seemed that all acids must therefore contain something in common and at the end of the eighteenth century, the French chemist Lavoisier erroneously proclaimed this common agent to be oxygen (indeed, he named oxygen from the Greek *oxus* "acid" and *gennao* "I produce").

Later it was realized that some acids, for example, hydrochloric acid, did not contain oxygen and soon hydrogen was identified as the key species. However, not all hydrogen-containing compounds are acidic, and at the end of nineteenth century it was understood that such compounds are acidic only if they produce hydrogen ions H^+ in aqueous solutions — the more acidic a compound, the more hydrogen ions are produced.

This was refined once more in **1923** by **J.N. Bronsted** who proposed simple definitions for acids and bases:

- **an acid is a species having a tendency to lose a proton;**
- **a base is a species having a tendency to accept a proton.**

For all acids and all bases acid-base interaction may be represented as:

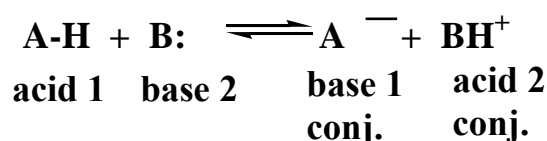

where $\text{A-H} / \text{A}^-$ and $\text{BH}^+ / \text{B:}$ are conjugate pairs of acids and bases.

Johannes Nicolaus Brønsted (February 22, 1879 – December 17, 1947) was a Danish physical chemist. In 1906 he published the first of his many papers on electron affinity, and simultaneously with the English chemist T. M. Lowry introduced the protonic theory of acid-base reactions in 1923. He became known as an authority on catalysis by acids and bases and was the namesake of the Brønsted catalysis equation.

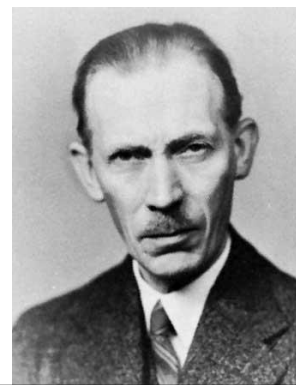

The strength of an acid is measured quantitatively by its acidity constant (acid ionization constant) K_a , which characterizes equilibrium in aqueous solutions of acids:

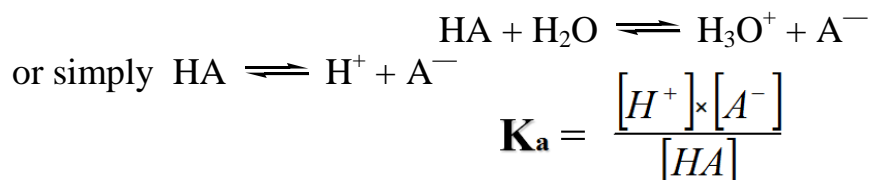

The greater K_a the stronger is an acid. Like pH, this is also expressed in a logarithmic form as $\text{p}K_a$.

$$\text{p}K_a = -\log K_a$$

Because of the minus sign in this definition, the lower the $\text{p}K_a$, the larger the equilibrium constant K_a , is and hence the stronger the acid. Basicity constant K_b characterizes strength of bases, but most often basicity of a substrate is measured by K_a of conjugate acid BH^+ , because there is an inverse relationship between the strength of an acid and its conjugate base:

- the stronger the acid HA , the weaker its conjugate base, A^- ;
- the stronger the base A^- , the weaker its conjugate acid AH .

5.2. Acidity of Organic Compounds

The most important factor in the strength of an acid is the stability of the conjugate base — the more stable the conjugate base, the stronger the acid. An important factor in the stability of the conjugate base is electronegativity of an element involved in an *acidic center (EH)* — the greater electronegative the element, the more stable the conjugate base. According to this acidic centers are arranged in the order of increasing acidity in a following way:

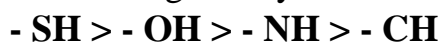

Ways to stabilize conjugate anions (A^-) include:

- (a) delocalizing the negative charge over conjugate base (anion);
- (b) solvating of substrates' molecules;
- (c) spreading out the charge over electron-withdrawing groups by the polarization of chemical bonds. In other words:

- all electron-withdrawing groups increase acidity;
- all electron-donating groups decrease it.

Four main types of organic acids may be distinguished:

OH-acids (alcohols, phenols, carboxylic acids);

SH-acids (thiols, thiophenols);

NH-acids (amines, amides, heterocyclic compounds);

CH-acids (hydrocarbons and their derivatives).

We'll begin the study of the acidic properties of organic substrates with the comparative characteristics of the OH-acids strength. **Carboxylic acids** are the strongest OH-acids due to high stability of carboxylate anions, which are stabilized through resonance. It was proved that negative charge is spread equally over the two oxygens, so each oxygen atom carries only half of the negative charge:

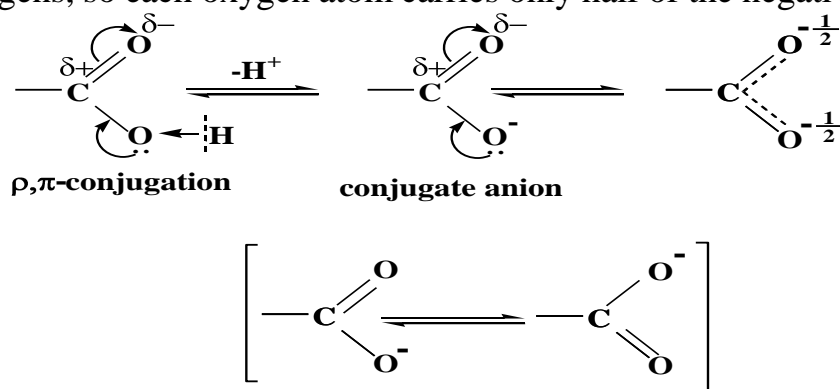

The strength of carboxylic acids can vary depending on what other groups are attached to the molecule. Thus, alkyl radicals, which exhibit positive Inductive effect, are electron-donating substituents and reduce acidity:



$\xrightarrow{\hspace{10em}}$
 decrease in acidity

Acidity of carboxylic acids can be enhanced by introduction of halogen atoms, which exhibit negative Inductive effect and are electro-withdrawing substituents:

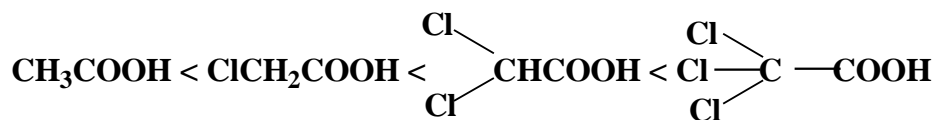

$\xrightarrow{\hspace{10em}}$
 increase in acidity

Increase in a distance between electron-withdrawing substituents and carboxylic groups reduce acidity:

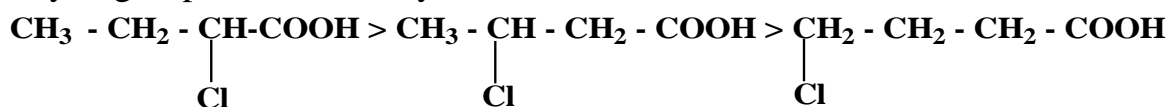

$\xrightarrow{\hspace{10em}}$
 decrease in acidity

Alcohols are weak OH-acids because alkoxide anions are unstable since their negative charge is localized on oxygen atom:



Localization of negative electric charge on oxygen is the response to the positive inductive effects of alkyl radicals. Alcohols have nearly the same acidity as water (table 5.1).

Table 5.1 — pKa of some alcohols

| Compounds | pKa |
|-------------------------------------|-------|
| H ₂ O | 15.74 |
| CH ₃ OH | 15.56 |
| C ₂ H ₅ OH | 16.6 |
| CCl ₃ CH ₂ OH | 12.24 |

Like acids alcohols interact with alkali metals with hydrogen gas evolution:

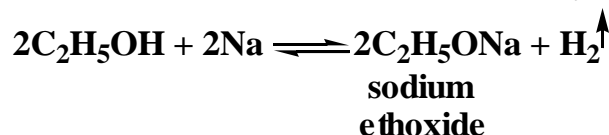

But alcohols don't interact with metal hydroxides because of their very low acidity. Metal alkoxides are easily decomposed by water, that also proves weak acidity of alcohols:

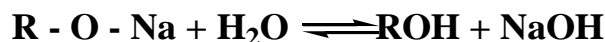

Polyhydric alcohols exhibit higher acidity than alcohols with only one hydroxyl group. They interact with metal hydroxides to form chelate coordination compounds:

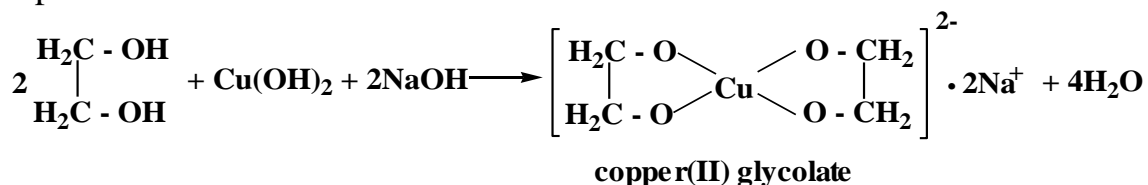

This is a test reaction on polyhydroxy alcohols. The resulting complex paints a solution in a bright blue color.

Phenols are the third group of OH-acids. They exhibit higher acidity than alcohols but lower than carboxylic acids. Their phenoxide anions are partially stabilized through resonance: negative charge of phenoxide ion is spread over the anion due to a negative resonance effect of a benzene ring:

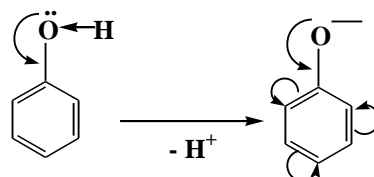

We can compare acidity of phenols and alcohols by comparing stability of their conjugate bases:

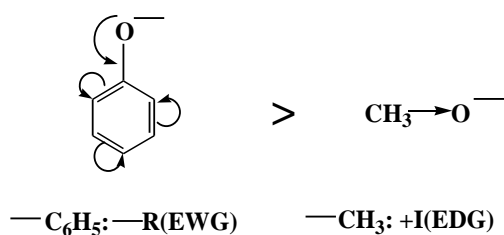

Stability of phenoxide anions is much greater than stability of alkoxide anions since benzene rings are the electron withdrawing substituents while alkyl radicals are electron donating groups.

Phenols can easily undergo interaction with alkali metals and their hydroxides:

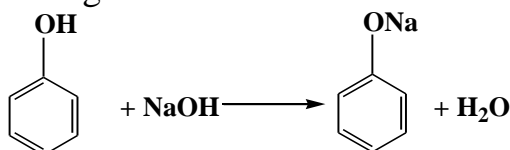

Introduction of functional groups changes acidity of phenols. The substituents in the ortho- and para- positions of the benzene ring have the greatest influence on their acidity:

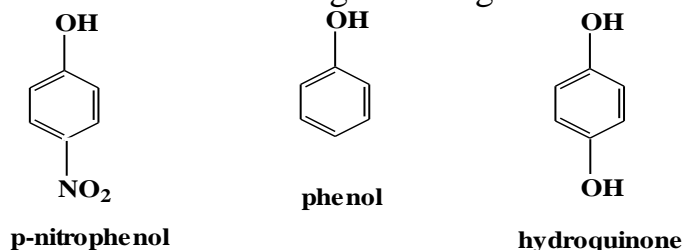

Let's compare acidity of given phenols by comparing stability of their conjugate bases:

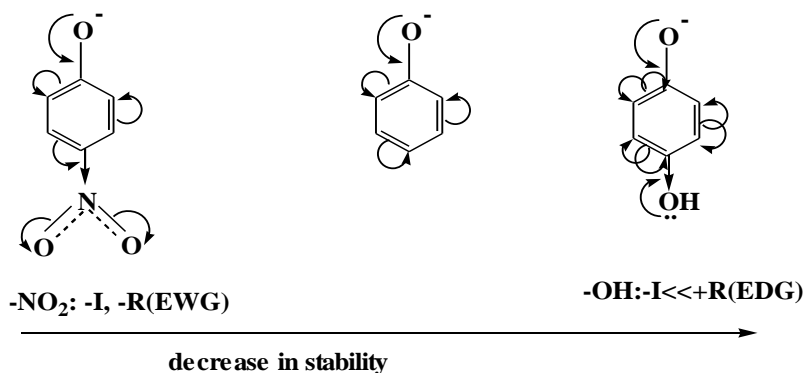

Thus, p-nitro phenol exhibits the highest acidity and hydroquinone — the lowest one in a given series:

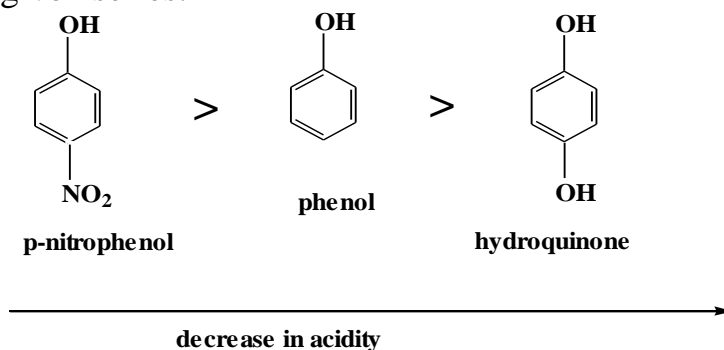



Biologically Important Alcohols and Phenols

The hydroxyl group appears in many biologically important molecules. Four metabolically important unsaturated primary alcohols are 3-methyl-2-buten-1-ol, geraniol, 3-methyl-3-buten-1-ol, and farnesol (figure 5.1).

The two smaller alcohols contain a five-carbon unit, called an **isoprene unit**, that is present in many natural products. This unit consists of a four-carbon chain with a one-carbon branch at carbon 2. These five-carbon alcohols can combine to give geraniol (10 carbons), which then can add yet another five-carbon unit to give farnesol (15 carbons). Note the isoprene units, marked off by dotted lines, in the structures of geraniol and farnesol.

Compounds of this type are called **terpenes**. Terpenes occur in many plants and flowers. They have 10, 15, 20, or more carbon atoms and are formed by linking isoprene units in various ways.

Geraniol, as its name implies, occurs in oil of geranium but also constitutes about 50 % of rose oil, the extract of rose petals. Geraniol is the biological precursor of a-pinene, a terpene that is the main component of turpentine.

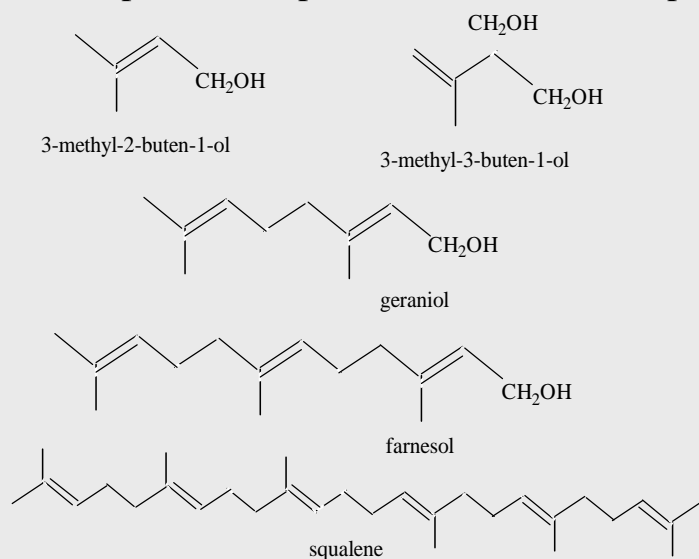

Farnesol, which occurs in the essential oils of rose and cyclamen, has a pleasing lily-of-the-valley odor. Both geraniol and farnesol are used in making perfumes.

Figure 5.1— Biologically important alcohols and phenols

Combination of two farnesol units leads to **squalene**, a 30-carbon hydrocarbon present in small amounts in the livers of most higher animals. Squalene is the biological precursor of steroids.

SH-acids are stronger than OH-acids, containing the same substituents. They can interact with metal hydroxides and metal oxides:

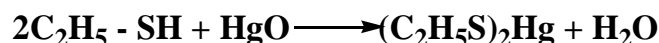
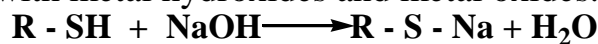

Their ability to form stable compounds with heavy metals is used in medicine. SH-acids are applied to bind and remove heavy metals and radio nuclides from a human body. British anti lewisite (BAL) was used during World War I as antidote for arsenic containing poison:

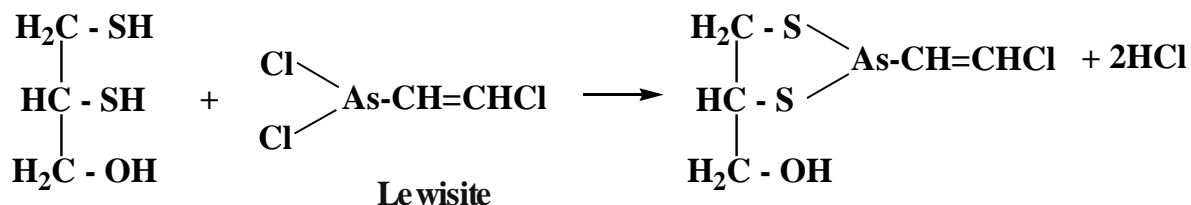

2,3-dimercapto
propanol
BAL

Later it was applied as useful antidote in mercury, lead and cadmium poisoning. Nowadays another thiol — unithiol is used to heal heavy metals poisoning and alcoholism:

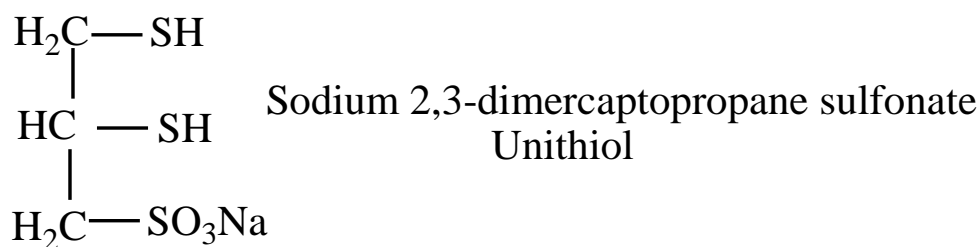

NH-acids are weaker than SH- and OH-acids. Still they are able to interact with alkali metals with hydrogen gas elimination:

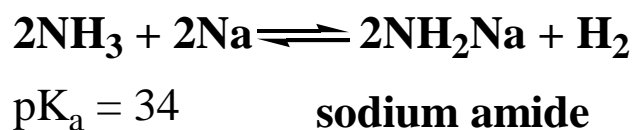

Acidity of aromatic amines is higher than acidity of aliphatic amines:

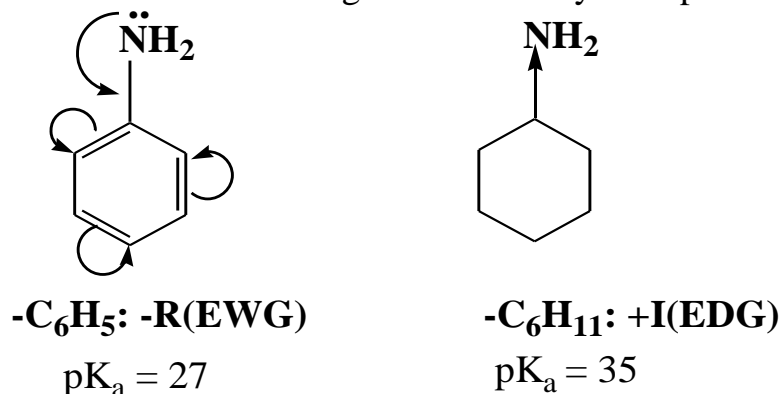

Among NH-acids heterocyclic aromatic compounds exhibit the highest acidity:

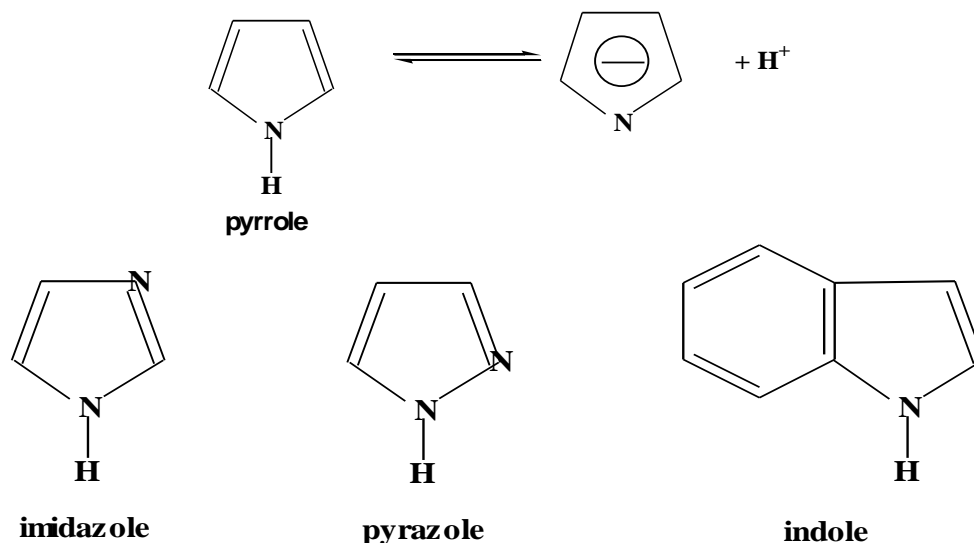

CH-acids are the weakest organic acids due to low electronegativity of carbon atoms. They exhibit very high pK_a values which testify to their low acidity (table 5.2).

Table 5.2 — pK_a of CH-acids

| Compounds | pK_a |
|------------------------|---------------|
| CH_4 | 40.0 |
| C_2H_6 | 50.0 |
| CH_3Cl | 10.2 |

Alkynes exhibit the highest acidity among hydrocarbons and their derivatives. They are involved in substitution of hydrogen atoms by metals:

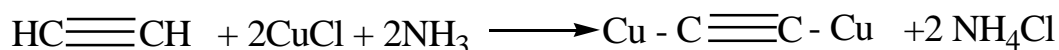

5.3. Basicity of Organic Compounds

Bases are proton acceptors. Two types of organic bases can be distinguished: π -bases, and n-bases. π -Bases (unsaturated and aromatic hydrocarbons) are very weak; they accept protons with the formation of unstable π -complexes:

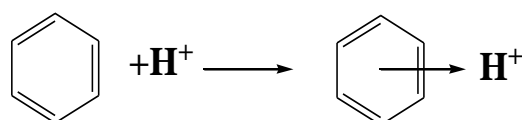

n-Bases contain atoms with lone electron pairs. Atom with a lone electron pair is defined as a **basic center (B:)**. They accept protons according to the scheme:



When an electron pair is localized on an atom B — it is available for protonation and a substrate exhibits strong basicity. When electron pair is delocalized — it is less available for protonation and a substrate exhibits low basicity.

n-Bases are classified according to their basic centers. Thus we can distinguish three types of n-bases:

Ammonium Bases



Oxonium Bases



The general classification of organic bases is given in figure 5.2.

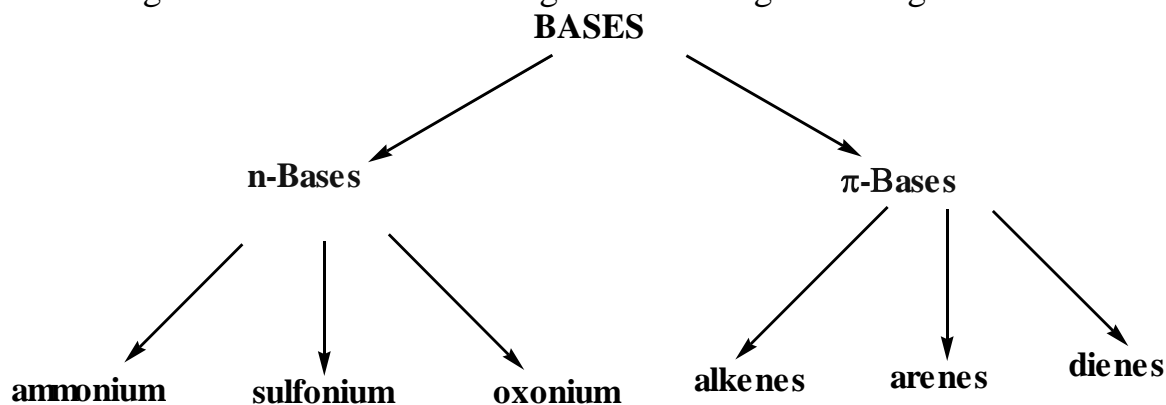
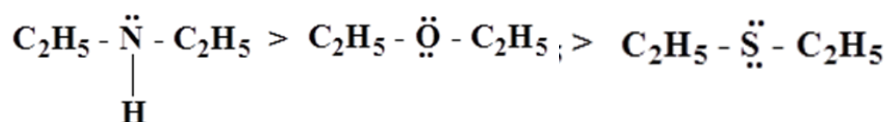

Figure 5.2 — Types of organic bases

Basicity of n-bases depends upon electronegativity of basic centers: the lower electronegativity of an atom, the stronger the base. Substrates containing different basic centers but identical substituents may be arranged in the following order of decreasing basicity:



Another factors effecting basicity are:

(a) solvating of substrates: the higher is solvation, the stronger is a base;
 (b) addition of substituents. The effect of substituents on basicity of substrates can be expressed by the following rule:

- all electron-donating groups increase basicity;
- all electron-withdrawing groups decrease basicity.

Amines are the strongest organic bases. They interact with acids to form salts:

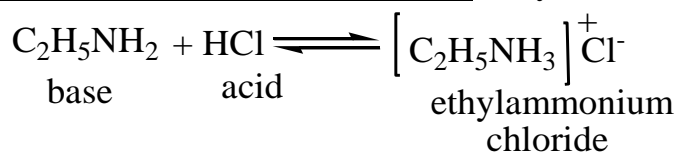

Secondary aliphatic amines are stronger than primary, because they contain two electron-donating substituents

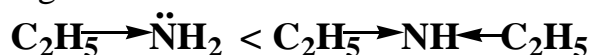

Basicity of aliphatic amines is greater than basicity of aromatic amines because alkyl radicals behave as electron-donating substituents while aryl radicals are electron-withdrawing groups:

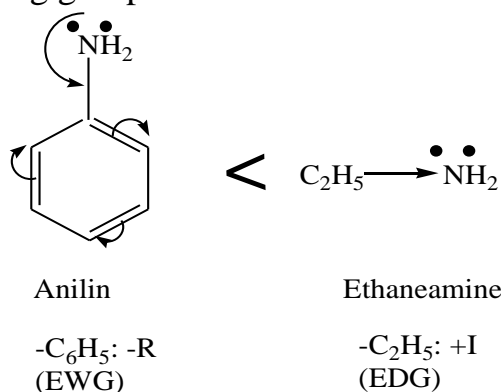

In substrates which contain several basic centers only the strongest one undergoes protonation. For example, novocain interacts with hydrochloric acid according to the following reaction:

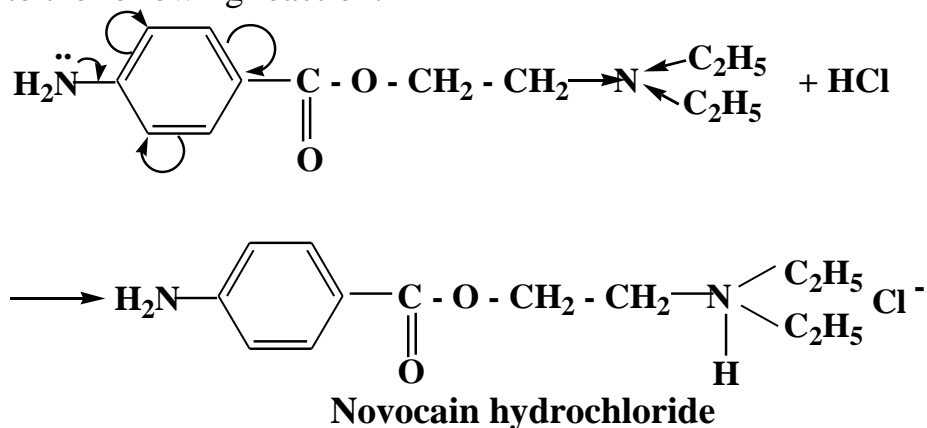

5.4 Amphoteric Properties of Organic Compounds

Most organic compounds exhibit amphoteric (or amphiprotic) properties, because they contain both acidic and basic groups in their molecules. A common example of amphoteric substances are amino acids that contain acidic carboxyl groups (-COOH) and basic amino groups (-NH₂).

In an aqueous solution at a certain compound-specific pH, this structure may change so that a proton from the COOH, carboxylic acid group, transfers to the NH₂, amino group, leaving an ion with both a negative charge and a positive charge, resulting in a net neutral charge because the number of protonated ammonium groups with a positive charge and deprotonated carboxylate groups with a negative charge are equal.

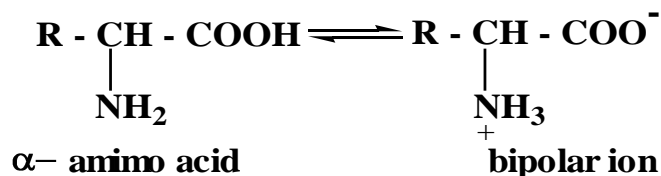

This ion is called a zwitterion (German meaning mongrel ion or hybrid ion). The zwitterion form of amino acids is the most stable form in the human body.

When adding an alkali to an amino acid solution, the hydrogen ion is removed from the acidic carboxyl group:

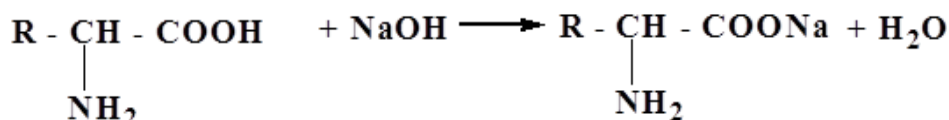

When adding an acid to an amino acid solution, the hydrogen ion is added to the basic NH₂⁻ group:

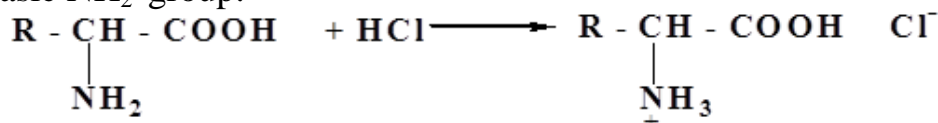

Amino acids interact with acids and bases to form salts.

Alcohols also exhibit acid-base duality, reacting with metal amides and sulfuric acid according to the following equations:

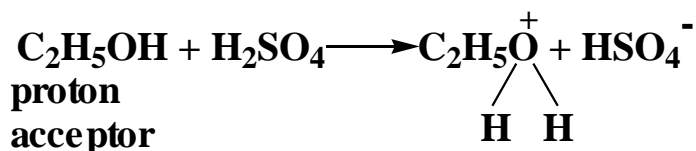
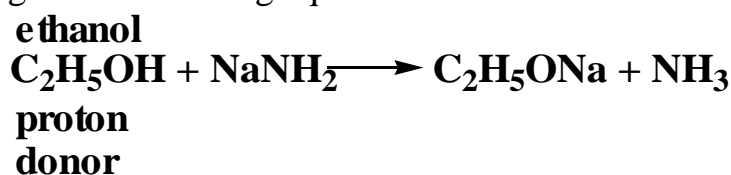

Acid-base duality is a specific feature of a large number of hetero aromatic compounds. For example, in the imidazole molecule pyridine nitrogen behaves as a basic center, while pyrrole nitrogen bounded to hydrogen atom is an NH acidic center:

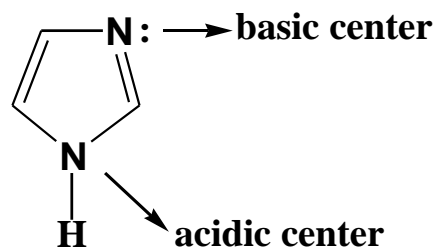

Acidic NH center in imidazole molecule is involved into reaction with an alkali:

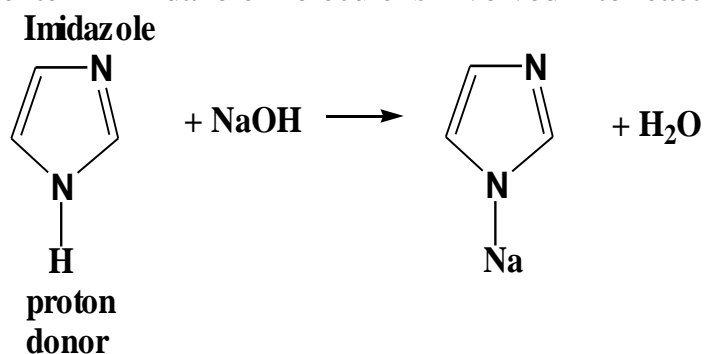

Basic center in its molecule is readily protonated, reacting with acids:

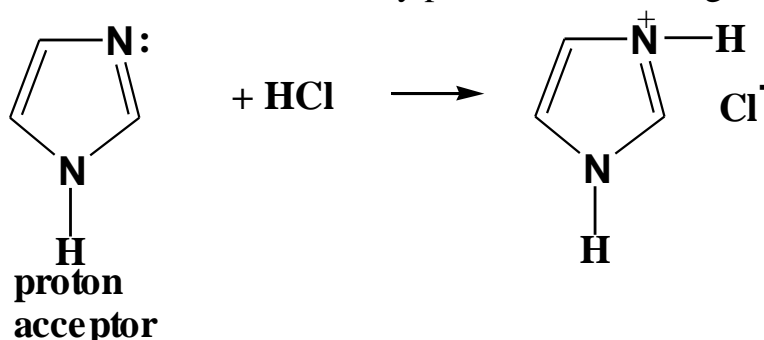

Peculiarities of imidazole structure explain an important role of some of its derivatives in enzymatic reactions. So imidazole cycle ability to donate a proton due to the NH group and to accept a proton due to the pyridine nitrogen atom makes it a participant the acid-base catalysis *in vivo*.

According to Bronsted theory of acids and bases, amphoteric properties of organic compounds are responsible for their association through **hydrogen bonds**. Such an association is typical for alcohols, carboxylic acids, some hetero cyclic compounds and other bioactive substrates. The examples of alcohols molecules and imidazole cycles associations are given below:

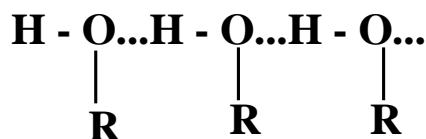

Association of alcohols molecules

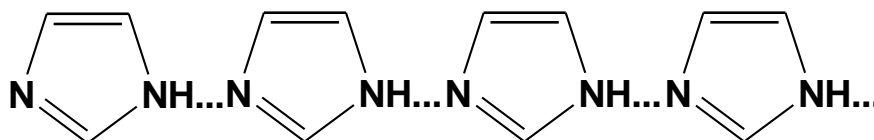

Association of imidazole molecules

Such associations of molecules affect physical properties of substances.



The alkaline acid diet is a nutritional approach based on the premise that optimal health demands that the acid and alkaline levels in the body must be in balance. Ingested food controls these levels, with each food supplying a different degree of acidity. The level of acidity is called the hydrogen potential (pH). Acids release hydrogen ions when dissolved in water and alkaline substances, or bases, do not. Sometimes it is easy to identify acidic foods by their taste, but this is not a fool-proof method. Lemons, for example, taste very acidic but are actually alkaline-forming when digested (figure 5.3).

Normal pH for the human body is about 7.4. If pH levels rise above about 7.7 or fall below 7, death or severe medical problems can result. In order to maintain an appropriate level, the body has buffers and checks that keep pH in balance. Eating improperly may put strain on the body as it tries to maintain this pH. The acid alkaline balance diet seeks to help the body maintain a proper pH.

Acidity is measured with a numerical pH scale that indicates a window of acceptable levels. When the body's biochemical balance falls outside this window, it is either in a state of acidosis, or too much acid; or alkalosis, which indicates alkaline levels are too high. Either of these conditions can have detrimental effects on health, but the most common issue is acidosis. Acidosis can interrupt enzyme processes, cause inflammation of tissues, promote tumor growth, or result in the loss of minerals such as potassium, magnesium, calcium, and sodium. An alkaline acid diet is meant to prevent these issues.

When planning an alkaline acid diet, one must first become familiar with typical acid levels in foods. The best rule to follow is to eat a balanced, varied diet with the primary focus on low alkaline foods like squash, soybeans, millet, wild rice, quinoa, and strawberries, and low acid foods such as sweet potatoes, blue berries, whole milk, oysters, and cottage cheese. High acid foods such as beef, pork, processed cheeses, peanuts, and coffee should be consumed in smaller quantities. High alkaline foods such as raw spinach, broccoli, raisins, and herbal teas should be eaten in moderation as well.



Figure 5.3 – Spinach is highly alkaline

Symptoms that may indicate the need for an alkaline acid diet to restore the body's biochemical balance are: fatigue, weakness, insomnia, mental fogginess, joint pain, water retention, muscle aches, and headaches. To confirm an alkaline acid imbalance, pH test strips can be purchased. These allow the individual to check acid levels in saliva and urine. In addition to selecting low acid and low alkaline foods for the alkaline acid diet, one should also reduce the amount of food eaten in one sitting and chew well to ensure the alkaline properties of saliva are able to successfully break down acids before they enter the digestive system.

5.5. Laboratory Work

ACIDITY AND BASICITY OF ORGANIC COMPOUNDS

Test 1. Preparing of sodium ethoxide and its hydrolysis

Pour 1 mL of ethyl alcohol C_2H_5OH into a dry test tube and add a small piece of sodium metal into it.

Collect the liberated hydrogen gas and bring it closer to a burner. You'll hear a bang, typical for hydrogen and oxygen interaction under heating.

Dissolve white sodium ethoxide precipitate in 2–4 mL of distilled water and add one drop of 1 % phenolphthalein solution. Explain why a prepared solution is colored pink? Write the equation of chemical reactions you have carried out:

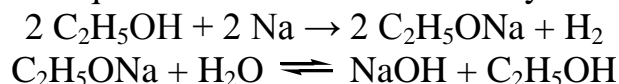

Test 2. Copper (II) glyceroxide preparing

Pour 5 drops of 2 % copper (II) sulfate solution into a test tube and treat it by 5 drops of 10 % sodium hydroxide solution. It will result in a blue copper (II) hydroxide precipitate formation. Dissolve this precipitate in glycerol. Mark the color of an obtained solution. This reaction is a test on alcohols containing more than one hydroxyl groups (polyhydric alcohols). Write the equations of fulfilled reactions.

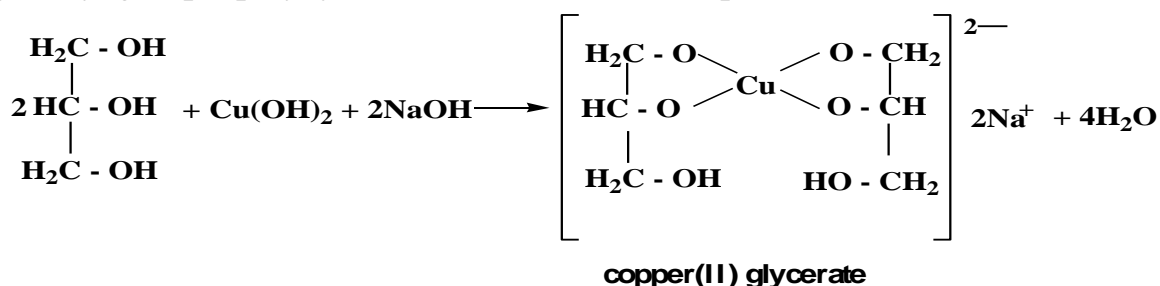

Test 3. Sodium phenoxide preparing

Dissolve 2–3 crystals of phenol in distilled water and treat the prepared emulsion by 10 % sodium hydroxide solution. What can you see? Add some drops of 10 % hydrochloric acid into it. Describe your observations. Write the equations of chemical reactions you have carried out:

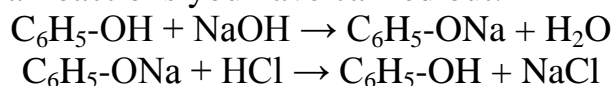

Test 4. Test reaction on phenol with iron (III) chloride

Dissolve 2–3 crystals of phenol in 2–3 mL of distilled water and add 1–2 drops of 3 % iron (III) chloride solution. Mark the color of a prepared solution. Write the equation of a performed reaction.

5.6. Exercises for the Self-Control

1. Compare acidity for the following compounds. Rank the following compounds in order of increasing acidity and explain the reasons for the observed acidity order:

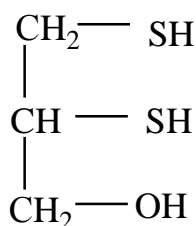

BAL

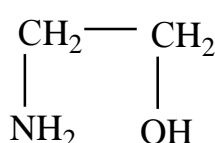

Calamine

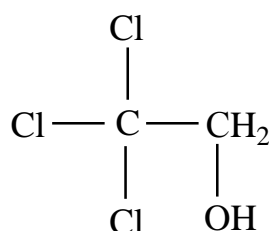

2,2,2-trichloroethanol-1

2. Rank the following compounds in order of increasing acid strength: phenol, *p*-nitro phenol, *p*-aminophenol. Explain the reason for your choice on the base of corresponding phenoxide ions stability.

3. What compound does exhibit the greater acidity: ethyl alcohol or ethyl thiol? Explain your decision based on stability of corresponding anions.

4. Compare basicity for the following compounds. Rank the following compounds in order of increasing basicity and explain the reasons for the observed basicity order

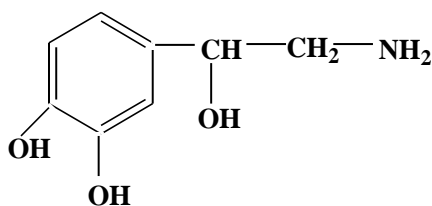

Noradrenalin

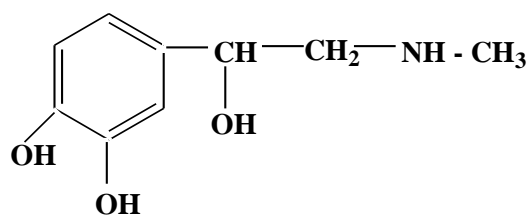

Adrenaline

5. Which are the stronger bases — aliphatic or aromatic amines? Do you expect Anesthesine to be a stronger or weaker base than ephedrine? Explain.

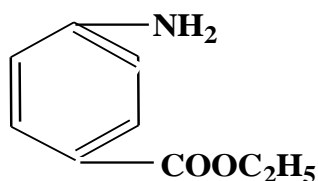

Anesthesine

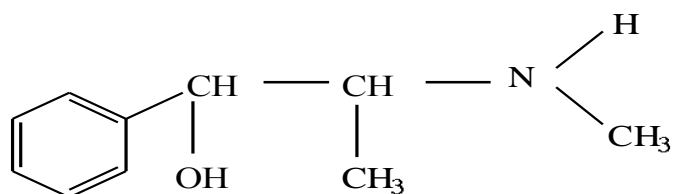

Ephedrine

PART II
GENERAL REGULARITIES OF ORGANIC COMPOUNDS
REACTIVITY AS THE CHEMICAL BASIS
OF THEIR BIOLOGICAL FUNCTIONING

CHAPTER 6
REACTIONS OF RADICAL SUBSTITUTION — S_R

After reading this chapter, you should be able to:

- define radicals and the methods of their generation;
- discuss three steps in the mechanism of radical substitution reactions;
- explain regioselectivity of alkane's bromination;
- describe radical reactions *in vivo*.

6.1. Radical Substitution at sp³-hybridized Carbon Atom

Radical substitution reactions are typical for saturated hydrocarbons: alkanes and cycloalkanes. Their molecules contain only sp³-hybridized carbon atoms hence only nonpolar C–C bonds and practically nonpolar C–H bonds present in them. These covalent bonds are very stable and can't be broken heterolytically under the effect of electrophilic and nucleophilic reagents. Thus saturated hydrocarbons are inert in most chemical processes. Actually they are active only in radical reactions that involve free radicals as intermediates.

There are three general ways of generating radicals:

- covalent bond cleavage under the effect of high temperature (thermolysis);
- covalent bond cleavage under the effect of light energy (photolysis);
- covalent bond cleavage under the effect of oxidation–reduction reactions.

Most radicals are extremely reactive since unpaired electrons are desperate to be paired up again. This means that radicals usually have a very short lifetime; they don't survive long before undergoing a chemical reaction.

Radical substitution reactions are chain reactions and there are three distinct phases in them:

- **initiation:** generation of radicals,
- **propagation:** the step where the products of the reaction are formed,
- **termination:** radicals are removed from the reaction mixture.

In general the mechanism of a hypothetical S_R reaction may be represented in a following way:

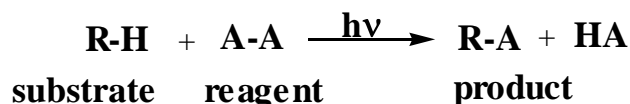

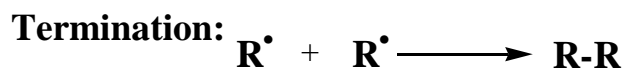
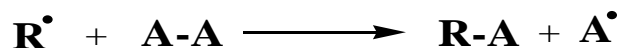

6.2. Halogenation of Alkanes

The bright examples of radical substitution are halogenation of alkanes. Most active alkanes react with chlorine to give alkyl chlorides. This type of reaction is important industrially since it is one of the few that allows compounds containing functional groups to be made from alkanes. For example, cyclohexane plus chlorine gas, in the presence of light, gives cyclohexyl chloride and hydrogen chloride:

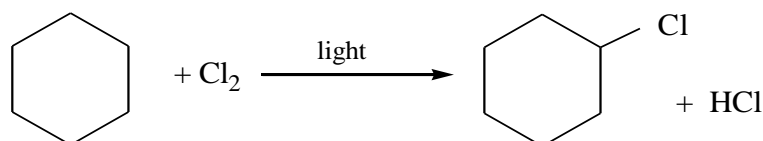

The mechanism of the reaction involves three phases typical for most radical processes:

Initiation:

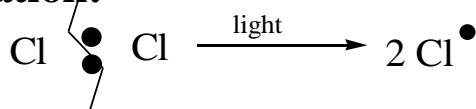

Propagation:

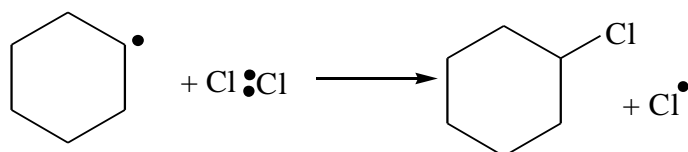
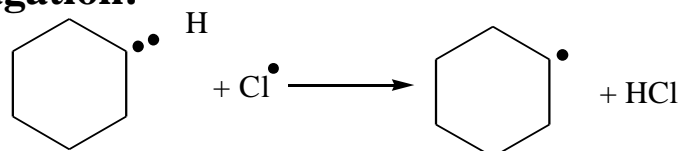

Termination:

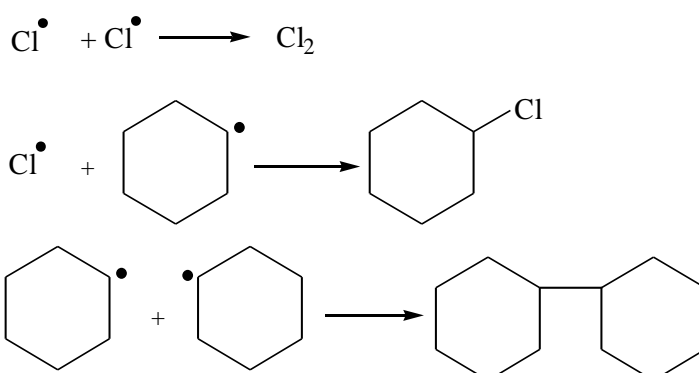

In this reaction only one product can be formed because all 12 hydrogen atoms are equivalent in cyclohexane molecule. For other alkanes, this may not be the case, and mixtures of alkyl chlorides can result. For example, propane is chlorinated to give a mixture of alkyl chlorides containing 45 % 1-chloropropane and 55 % 2-chloropropane:

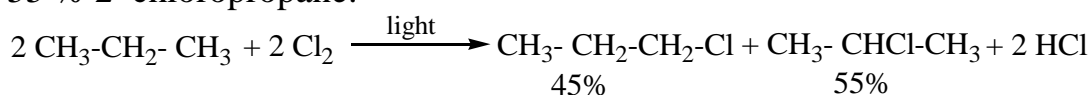

How can we explain the ratios of products that are formed? The key is to look at the relative stabilities of the radicals involved in the reaction and the strengths of the bonds that are formed and broken. The table 6.1 shows the bond dissociation energy that is the energy required to break the bond in a homolytic fashion, generating alkyl and hydrogen radicals. Note how the bonds get weaker as we move down the table 6.1.

Table 6.1. — Bond dissociation energy of different C-H bonds in saturated hydrocarbons

| A type of C-H bond | Bond dissociation energy, kJ/mol |
|--------------------------------------|----------------------------------|
| CH ₃ -H | 435 |
| CH ₃ CH ₂ -H | 410 |
| (CH ₃) ₂ CH-H | 397 |
| (CH ₃) ₃ C-H | 380 |

Thus most stable is the bond between carbon primary – H, and less stable is the bond carbon tertiary – H:

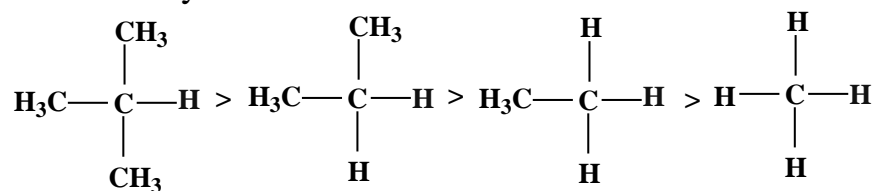

In a given series from left to right there is an increase in carbon-hydrogen bond energy thus it becomes clear why products of substitution at tertiary and primary carbons predominate in the mixture of alkyl chlorides.

Bromination is much more selective in comparison with chlorination because reactivity of bromine is much less than reactivity of chlorine.

A specific feature of alkanes' bromination is its **regioselectivity**. Regioselectivity is a preferable running of the reaction by one of several reactionary centers in the molecule. For example, propane bromination results in only one main product — 2-bromopropane production. Hydrogen atom is substituted at secondary carbon only:

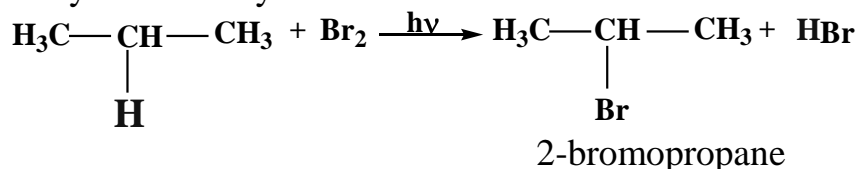

Mechanism S_R

Initiation:

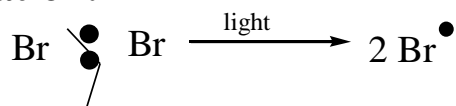

Propagation:

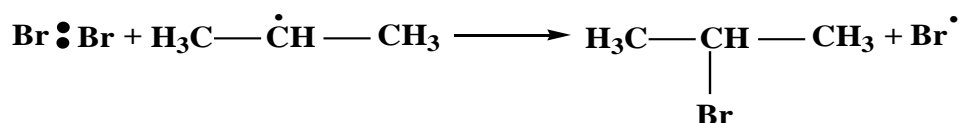
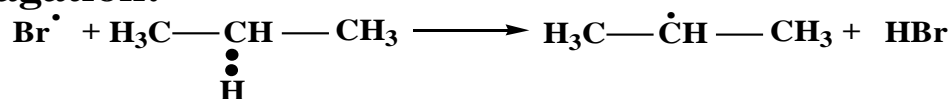

Termination:

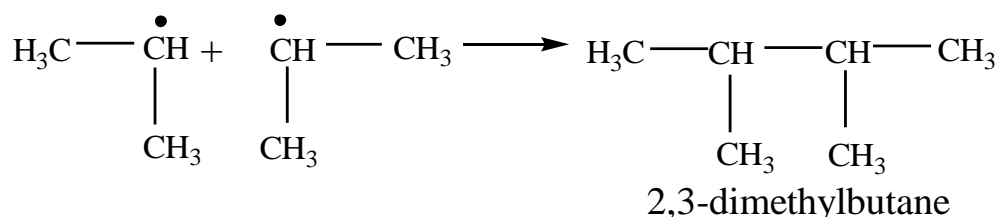
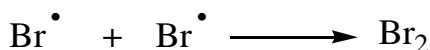
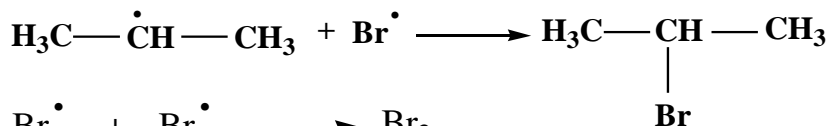

Consider the examples of alkane's chlorination and bromination reactions, following conclusions can be drawn:

- bromine radicals are less reactive than chlorine radicals;
- bromine radicals tend to be more selective in its reactions, and prefers to react with the weaker R-H bonds;
- the more reactive chlorine radical is less discriminating in what it reacts with.

Radical substitution reactions occur *in vivo*. Radicals are generated in the process of redox processes.



Free radicals, also known simply as radicals, are organic molecules responsible for aging, tissue damage, and possibly some diseases. These molecules are very unstable, therefore they look to bond with other molecules, destroying their health and further continuing the damaging process. Antioxidants, present in many foods, are molecules that prevent free radicals from harming healthy tissue.

Radicals do play a key role in several biological processes. They play a part in the work of the white blood cells called phagocytes, which "eat" bacteria and other pathogens in the body. They also are believed to be involved in a process called redox signaling, where they are thought to act as cellular messengers.



The Problem with Radicals. Some molecules are unstable. They do not have an even number of electrons, so they are always searching for an extra electron they can "steal" to become stable. Out in the world, this is a normal process, but in the body, it can result in unnecessary and unwanted damage.

Cigarette smoking creates free radicals.

Free radicals are "free" because they float around until they stabilize, and "radical" in the sense that there are a wide variety of molecules from which they can take an electron. The damage doesn't stop there, however, as the new molecule, say a piece of a cell wall, is now also missing an electron and has become another free radical. This snowball effect can wreak havoc on healthy tissue.

6.3. Exercises for the Self-Control

1. Write equations for all steps (initiation, propagation, termination) in free radical bromination of

- propane;
- isobutane.

2. Write equations for all steps (initiation, propagation, termination) in free radical chlorination of cyclopentane.

3. Write the structures of all possible products of monobromination of n-pentane. Note the complexity of the product mixture compared to that from the corresponding reaction with cyclopentane.

4. Using structural formulas write equations for the following reactions and name each organic product:

- the monobromination of n-butane;
- the monobromination of isooctane;
- the monochlorination of isobutene.

CHAPTER 7

ELECTROPHILIC ADDITION TO UNSATURATED HYDROCARBONS— A_E

After reading this chapter, you should be able to:

- discuss mechanism of electrophilic addition to a multiple bond;
- consider reactions of alkenes hydrogenation, halogenation, hydro halogenation and hydration;
- define Markovnikov's rule and give the examples of hydration and hydrohalogenation of unsymmetrical alkenes;
- explain the reason why unsaturated compounds which contain electron-withdrawing substituents give anti-Markovnikov's products;
- explain peculiarity of electrophilic addition to conjugated dienes.

7.1. The Mechanism of Electrophilic Addition to a Multiple Bond — A_E

This type of chemical reactions is typical for alkenes and other unsaturated hydrocarbons such as dienes and alkynes. The carbon-carbon double or triple bond, because of its π -electrons, is a nucleophile. It can act as a supplier of π -electrons to an electrophilic reagent. Thus unsaturated hydrocarbons and their derivatives behave as nucleophilic substrates that add electrophiles in the three step process. The π -bond is weaker than σ -bond, thus it is π -electrons that are involved in addition to alkenes and other unsaturated compounds.

Step 1. An electrophile is attracted to the double bond of a substrate by electrostatic forces. It results in formation an unstable π -complex

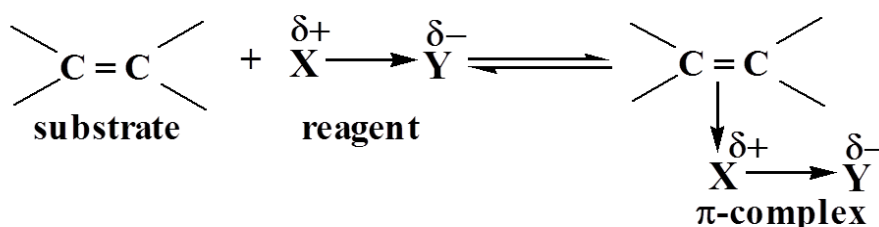

Step 2. The two π -electrons are used to form a σ -bond between the reagent and one of the two carbon atoms. The other carbon acquires a positive charge, producing a σ -complex (or carbocation):

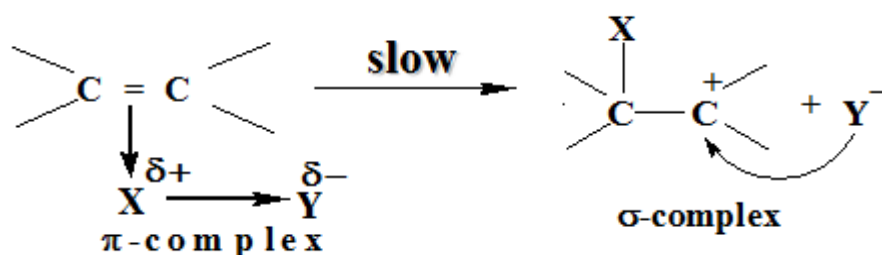

Step 3. The resulting carbocation is extremely reactive; it rapidly combines with some nucleophile, producing a molecule:

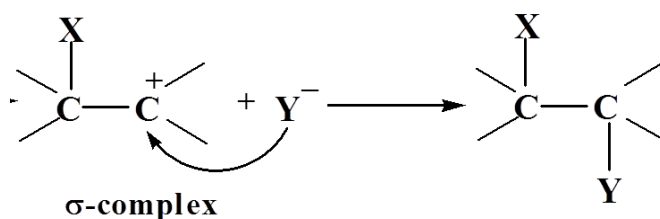

Examining the mechanism of electrophilic addition reaction you have verified that two groups actually add to the double bond. These groups are the electrophile and the nucleophile. The electrophilic portion of the reagent first adds to the double bond, followed by the addition of the nucleophilic portion of the reagent. The electrophilic and nucleophilic parts of a reagent add either to the opposite sides of the substrate, an **anti** addition, or to the same side of the substrate, a **syn** addition (figure 7.1). Most electrophilic addition reactions favor anti stereochemistry.

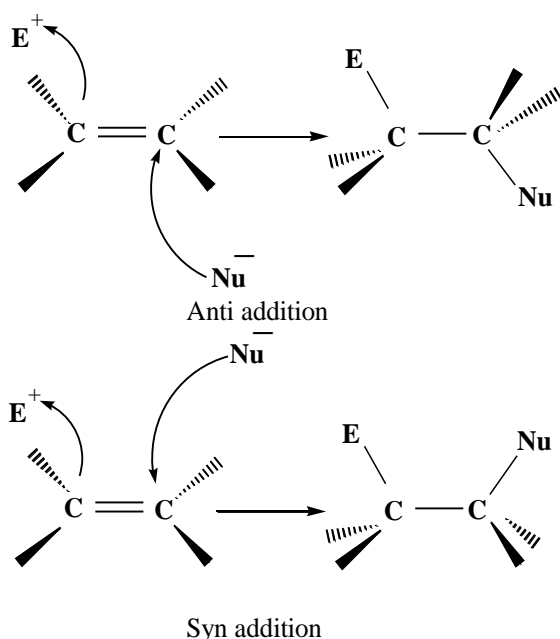
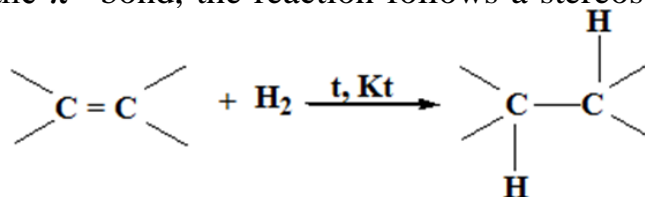

Figure 7.1 — Anti addition means the electrophile and nucleophile add 180° apart.
With a syn addition they add 0° apart

7.2. Electrophilic Addition to Alkenes and Alkynes

Addition of hydrogen (hydrogenation)

Adding hydrogen to a double or triple bond is called a reduction reaction. As the hydrogen adds to the π -bond, the reaction follows a stereospecific anti addition to the bond:



A direct addition of hydrogen requires the presence of a metal catalyst such as platinum, palladium, rhodium, or nickel.

Addition of halogens (halogenation)

Halogens readily add to alkenes to form vicinal dihalides. Of the various halogens, chemists commonly use bromine and chlorine. They do not use fluorine because it reacts explosively and produces many side reactions. They do not use iodine because vicinal diiodides decompose readily.

The addition of bromine can be used as a chemical test for the presence of unsaturation in an organic compound. Bromine solutions in tetra chloromethane are dark reddish-brown, and the unsaturated compound and its bromine adduct are usually both colorless. As the bromine solution is added to the unsaturated compound, the bromine color disappears:

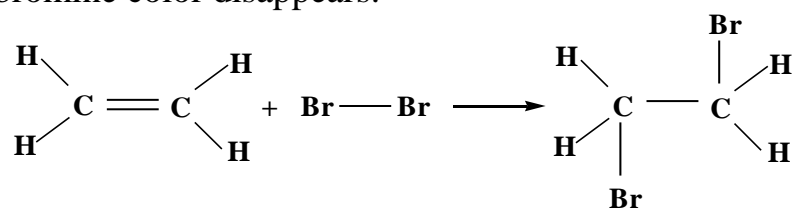

The mechanism of bromination involves polarization of bromine molecule under the effect of a substrate, and a formation of an intermediate bromonium cation, which is a three membered ring with considerable ring strain. This ring strain combined with the positive charge on the halogen atom makes the cation very electrophilic thus in the next step it readily adds bromide anion, forming a stable dibromide:

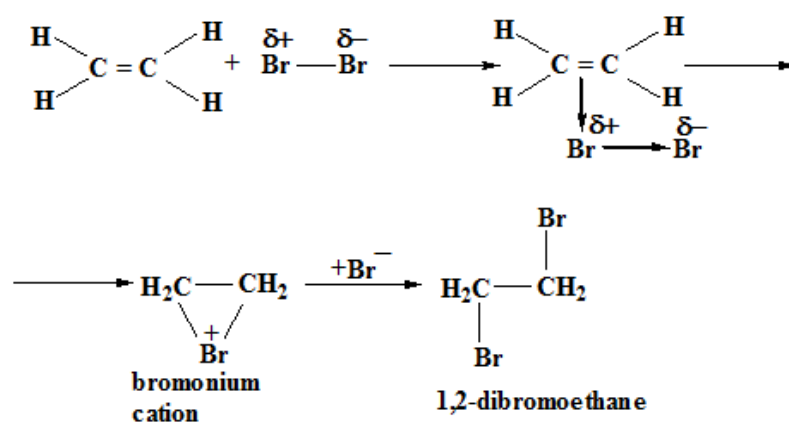

Addition of hydrogen halides (hydro halogenation reactions)

Hydrogen halides add to the π -bond of alkenes to form alkyl halides. Chemists perform hydrohalogenation reactions by bubbling the gaseous hydrogen halide through the reaction mixture in a non-nucleophilic solvent.

The hydrogen ion (or proton) adds to one carbon of the double bond, and the remainder of the acid becomes connected to the other carbon:

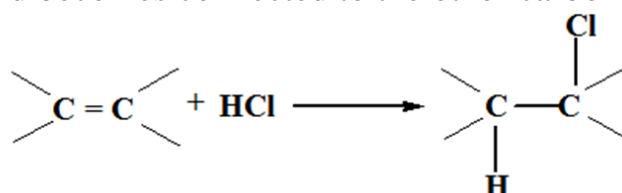

Addition of water (hydration)

Under acidic conditions, water adds to alkenes to form alcohols in an acid-catalyzed hydration reaction:

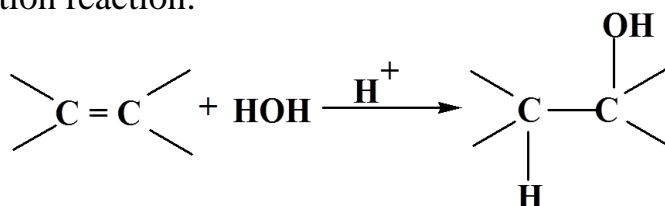

Hydration is a vital biochemical process, which occurs in all biological systems. The mechanism of ethene acid-catalyzed hydration (figure 7.2) involves three main steps:

- protonation that results in the carbocation formation;
- addition of water molecule that gives an oxonium cation;
- deprotonation or return of a catalyst.

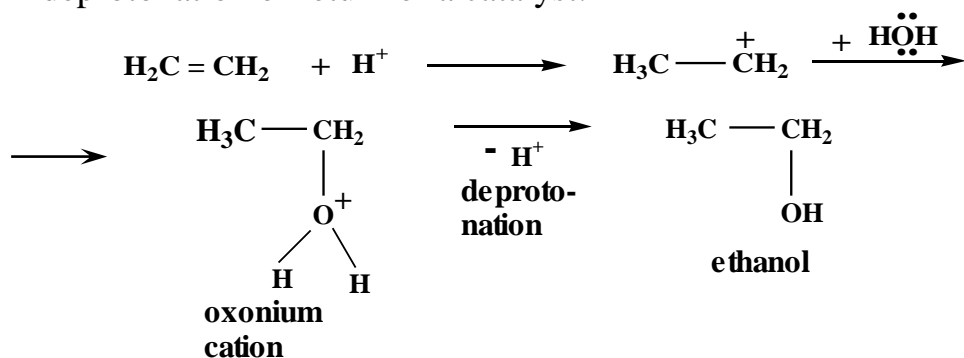
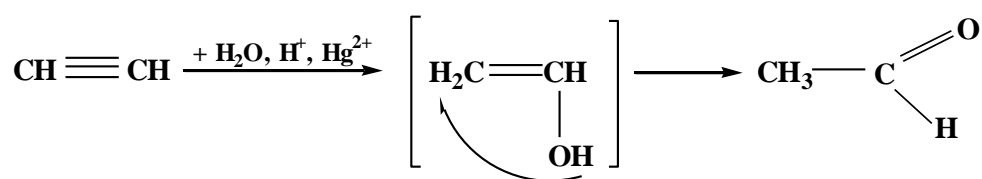

Figure 7.2 — The mechanism of ethene acid catalyzed hydration

Acid-catalyzed hydration reactions take place with alkyne substrates. Their acid-catalyzed hydrolysis is slow, but speeds up when mercury (II) salts are used as a catalyst. The initial product of a hydration reaction is a vinyl alcohol, but the vinyl alcohol rapidly tautomerizes to form a carbonyl compound:



7.3. The Addition of Unsymmetrical Reagents to Unsymmetrical Alkenes and Alkynes

The addition of unsymmetrical reagents to unsymmetrical alkenes and alkynes obey **Markovnikov's rule (1870)**: when an unsymmetrical reagent adds to an unsymmetrical alkene or alkyne, the hydrogen bonds to a carbon of the multiple bond that has the greater number of hydrogen atoms attached to it.

Vladimir Markovnikov (December 22, 1837 — February 11, 1904) was a Russian chemist. He is best known for Markovnikov's rule, elucidated in 1869 to describe addition reactions of H–X to alkenes. Markovnikov also contributed to organic chemistry by finding carbon rings with more than six carbon atoms, a ring with four carbon atoms in 1879, and a ring with seven in 1889. Markovnikov also showed that butyric and isobutyric acids have the same chemical formula (C₄H₈O₂) but different structures; i.e., they are isomers.



Markovnikov's rule readily translates to the modern understanding of chemical mechanisms. The electrophile adds to the double bond in such a way that the most stable carbocation intermediate forms (secondary carbocations are more stable than primary):

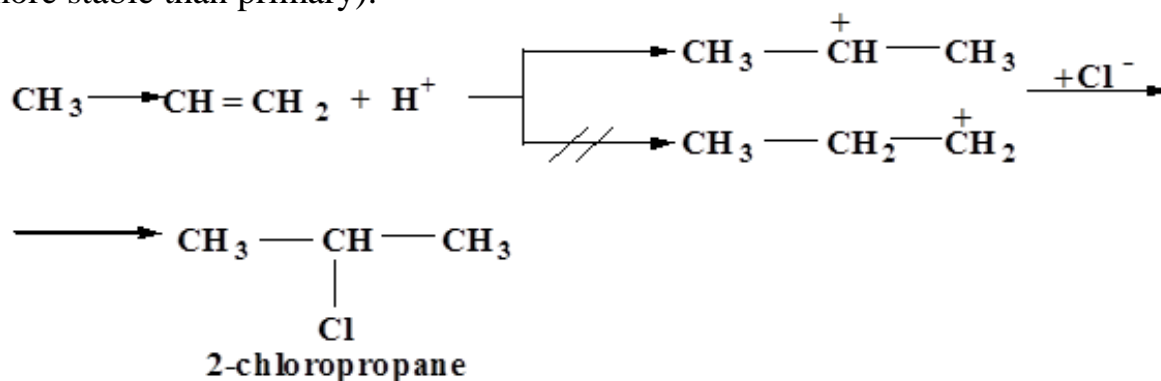

Thus, in modern terms, Markovnikov's rule states that the electrophile adds to the double bond in such a way to form the most stable carbocation.

However it was noticed that hydrohalogenation and hydration of unsaturated compounds which contain electron-withdrawing substituents **gives anti-Markovnikov's products**. Thus hydration of unsaturated carboxylic acids doesn't obey the Markovnikov's rule and a nucleophile is always attached to the β -carbon atom. This can be explained by the destabilization of the carbocation with the positive charge on the α -carbon atom due to the partial positive charge on the carbonyl atom of the carboxyl group.

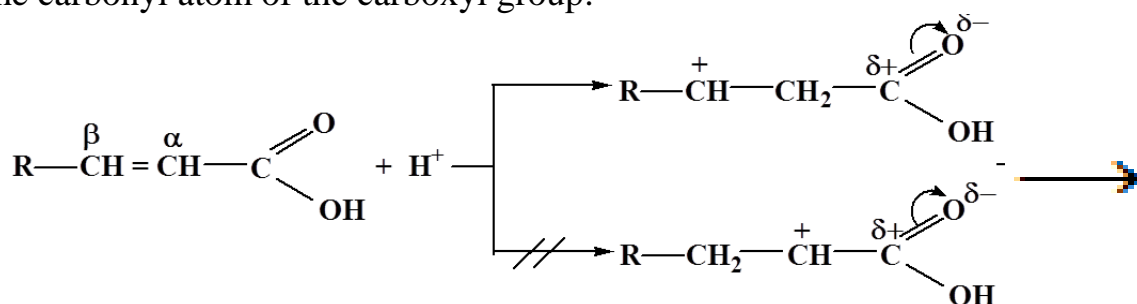

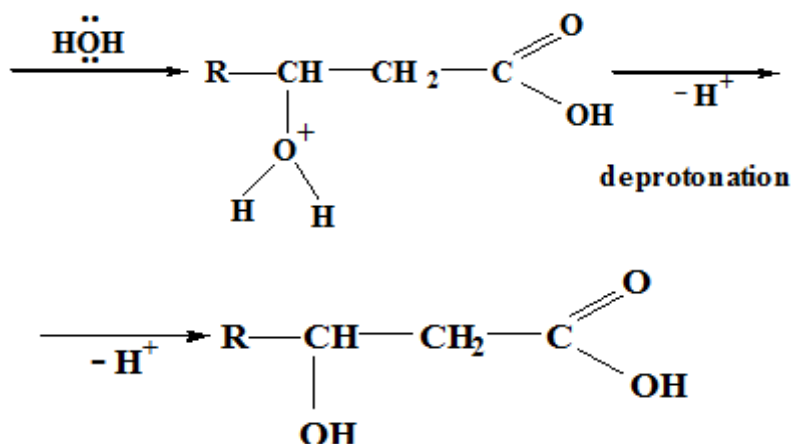

Hydration of unsaturated acids *in vivo* is a step in β -oxidation of fatty acids.

7.4. Electrophilic Addition to Conjugated Systems

The most striking result is obtained when conjugated dienes undergo electrophilic addition to the delocalized π -bond. Two products are isolated from a product mixture:

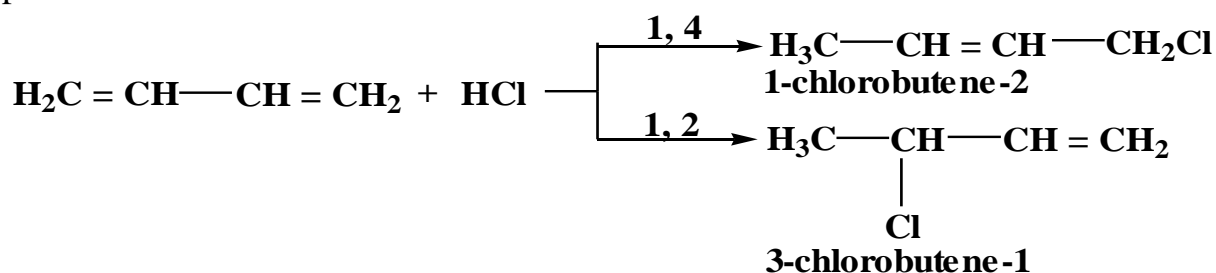

Thus we come to believe that electrophilic addition reaction with a conjugated diene, the reaction has two possible pathways. The first possible pathway adds the HCl across one of the double bond. This reaction is called a **1, 2-addition** reaction. The second possible pathway adds the HCl to the ends of the diene. This is called a **1, 4-addition**, or a **conjugate** addition, reaction.

This phenomenon can be explained by a formation of two identical carbocations stabilized through resonance:

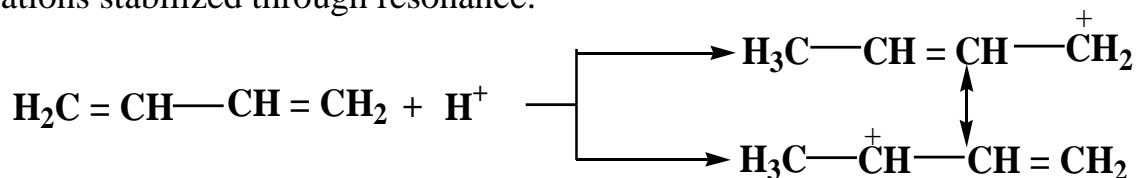

In this reaction, the chemists control the reaction pathway by controlling the temperature. Table 7.1 summarizes the change in the ratio of 1, 2- and 1, 4-addition products in the reaction of butadiene-1, 3 with HCl according to reaction temperature.

Table 7.1 — The effect of reaction temperature on the ratio of 1, 2- and 1, 4-addition to butadiene-1, 3

| Temperature (°C) | 1,2-Addition (%) | 1,4-Addition (%) |
|------------------|------------------|------------------|
| - 78 | 81 | 19 |
| + 25 | 56 | 44 |
| + 45 | 15 | 85 |

7.5. Exercises for the Self-Control

1. Arrange the following compounds in order of increasing rate of acid-catalyzed hydration reaction: 2-methylpropene, propene-1, and 3-methylbutene-1. What is the product in each case?

2. Write an equation for the acid catalyzed addition of water to propene. Describe the mechanism for this reaction. Which compound is more reactive towards electrophilic addition: propene or ethene? Why?

3. Write an equation for HBr addition to butene-1. Describe the mechanism of this reaction.

4. Write an equation for the addition of H₂ to butene-2. Describe the mechanism of this reaction.

5. Write the equation of a chemical reaction for isoprene (2-methylbutadiene-1, 3) bromination with one mole of bromine. Explain, why the product of 1, 4-addition is preferable.

CHAPTER 8 THE REACTIONS OF ELECTROPHILIC AROMATIC SUBSTITUTION — S_E

After reading this chapter, you should be able to:

- discuss mechanism of electrophilic aromatic substitution;
- define ring-activating and ring-deactivating substituents;
- explain the role of catalysts in aromatic substitution reactions;
- give the examples of ortho, para and meta-directing substituents;
- consider electrophilic substitution in heteroaromatic compounds.

8.1. The Mechanism of Electrophilic Aromatic Substitution — S_E

The most common reactions of aromatic compounds involve substitution of other atoms and groups for ring hydrogen. These reactions are known as aromatic substitution reactions. All aromatic compounds are nucleophilic substrates due to high electron density of aromatic rings; therefore they are attacked by electrophilic reagents. Mechanism of S_E reactions involves three stages.

Step 1. Attack by an electrophile on the aromatic ring and formation of an unstable π -complex:

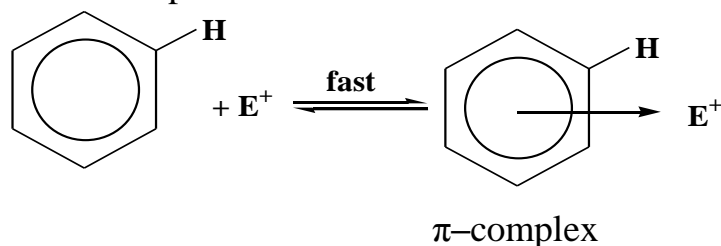

Step 2. π -Complex slowly transforms into σ -complex (the cation). To form an σ -bond with a ring carbon two π -electrons from aromatic π -system pass to the vacant orbital of an electrophile. The ring carbon becomes sp^3 -hybridized:

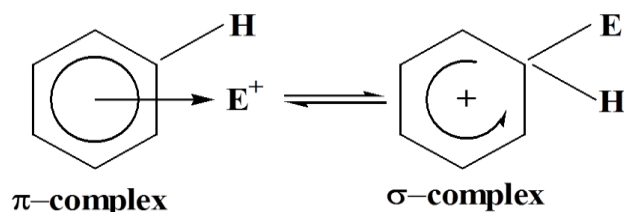

Step 3. σ -Complex is unstable because it is not aromatic. In order to restore the aromaticity a proton is removed from a sp^3 -hybridized carbon atom:

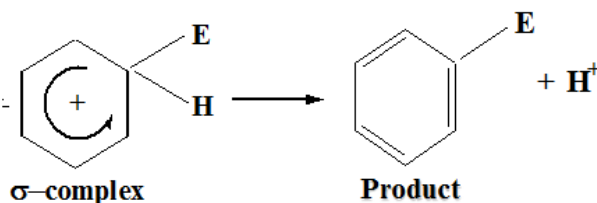

The main types of aromatic substitution reactions are:

1. Halogenation (chlorination, bromination) is a substitution of hydrogen in the benzene ring by a halogen:

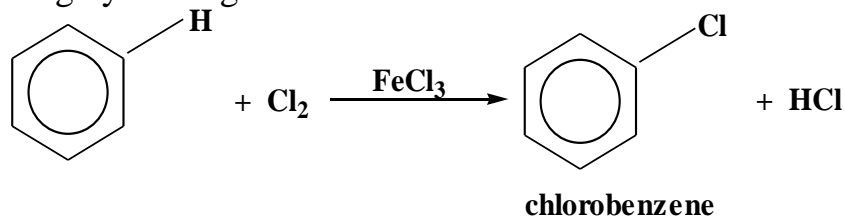

Chlorine itself is a very reactive electrophile. It is indeed a dangerous compound and should be handled only with special precautions. Even so it is able to react with benzene in the presence of a catalyst only. Salts $FeCl_3$, $FeBr_3$, $AlCl_3$ catalyze halogenation, which are well-known Lewis acids.

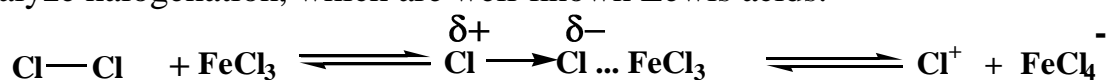

The role of catalysts in aromatic substitution reactions is to generate electrophiles.



Halogenation of aromatic compounds occurs *in vivo*. Thus iodination of α -amino acid tyrosine results in formation of 3-iodotyrosine and 3,5-diiodotyrosine, which are precursors of a thyroid glands hormone thyroxin:

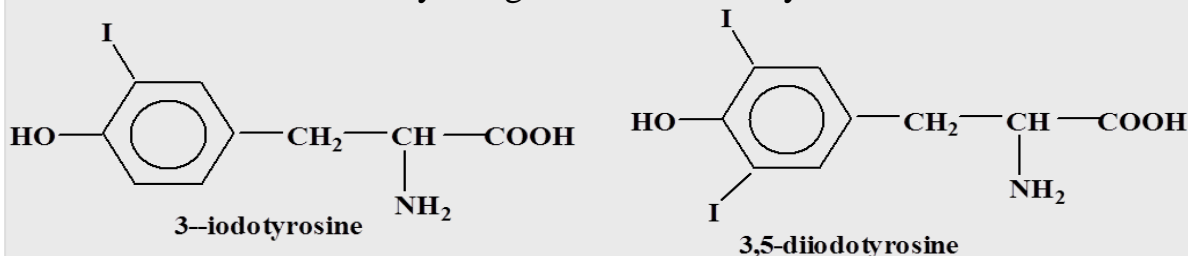

2. Nitration. Perhaps the most important of all the reactions in this chapter is nitration, the introduction of a nitro group into an aromatic system. Aromatic nitration requires very powerful reagents, the most typical being a mixture of concentrated nitric and sulfuric acids:

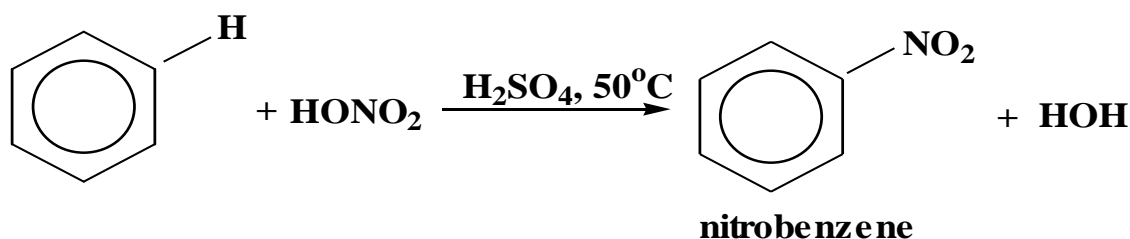

The first step is the formation of a very powerful electrophile known as a nitronium cation NO_2^+ . It is prepared by the interaction of nitric acid with the strong acids. Sulfuric acid is the stronger and it protonates the nitric acid on the OH group so that a molecule of water can leave:

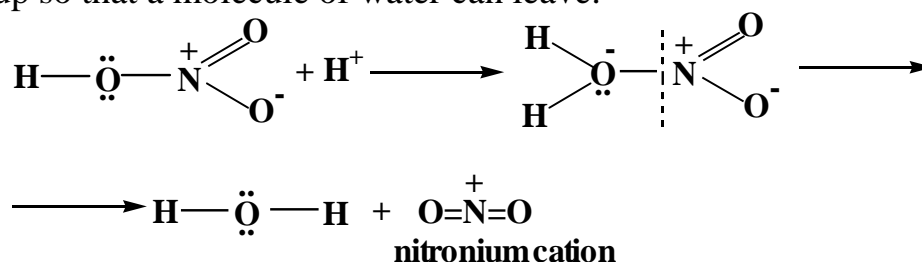

In general:

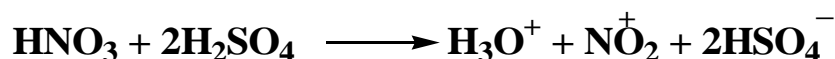

3. Sulfonation. Sulfonation of benzene is carried out with concentrated sulfuric acid containing an excess of sulfur trioxide dissolved in it:

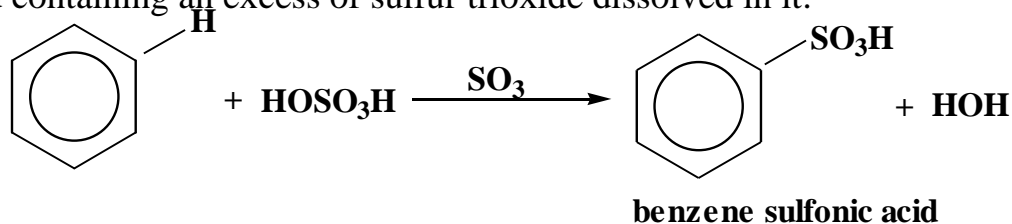

Suggest that it SO_3 the sulphonating agent, thus the reaction doesn't require a catalyst since SO_3 is a strong electrophile (figure 8.1).

Mechanism of benzene sulfonation can be represented by the following scheme:

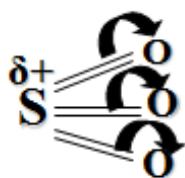
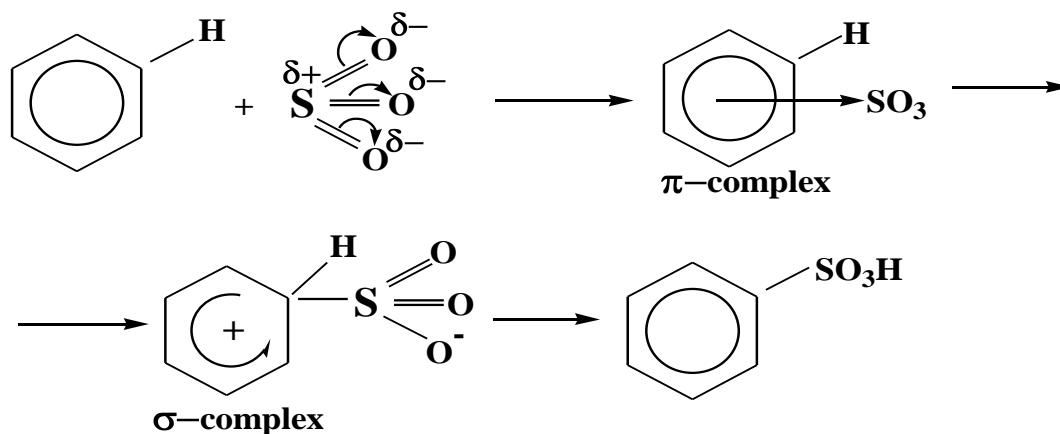
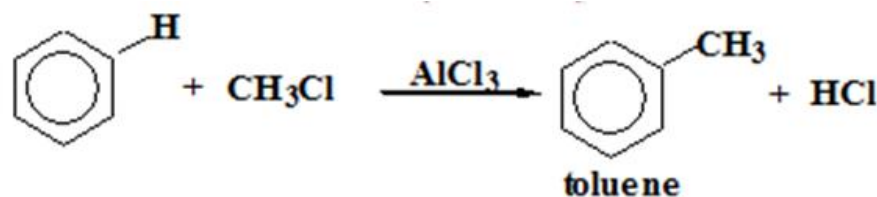
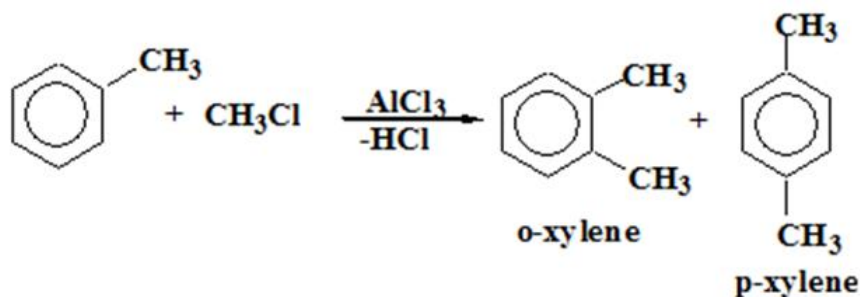

Figure 8.1 — Distribution of electron density in sulfur trioxide molecule

4. Friedel–Crafts Alkylation. Alkylation reaction is a general method for producing benzene homologues — alkyl benzenes. Charles Friedel (1832–1899), a French chemist, and James Crafts (1839–1917), an American mining engineer, worked together in Paris where in 1877 they discovered the Friedel–Crafts reaction:



Alkylation seldom stops at the stage of mono substitution, and proceeds further as a first alkyl group introduced into a benzene molecule activates it in the electrophilic substitution reactions:



The role of AlCl_3 as a catalyst becomes clear from the following scheme:

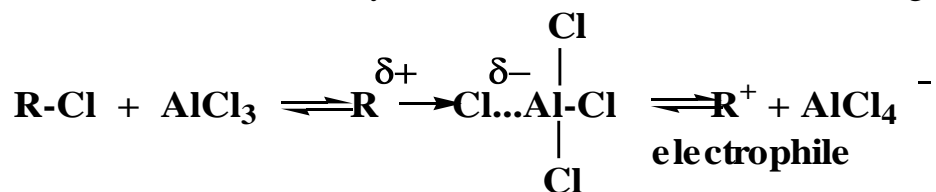

In alkylation reactions in addition to the alkyl halides some other sources of carbocations may be used, e.g. alkenes in an acidic medium:

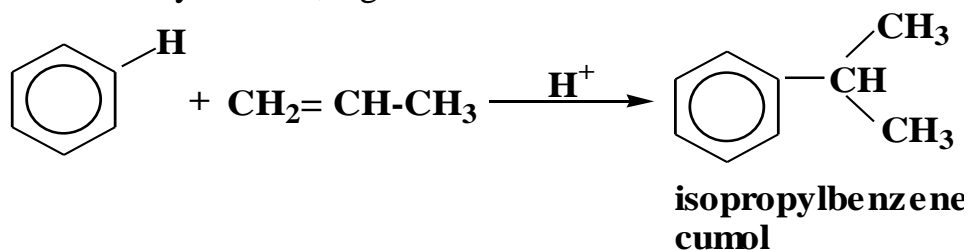

5. Friedel–Crafts Acylation. This reaction provides a useful general route to aromatic ketones. The electrophile is an acyl cation generated from an acid derivative, usually an acyl halide:

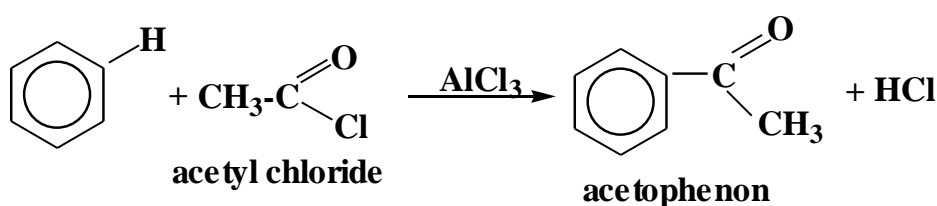

8.2. Ring–Activating and Ring–Deactivating Substituents

Further examination of aromatic substitution reactions requires an understanding of how substituents already present on an aromatic ring effect further substitution reactions. For example, consider the relative nitration rates of the following compounds, all under the same reaction conditions:

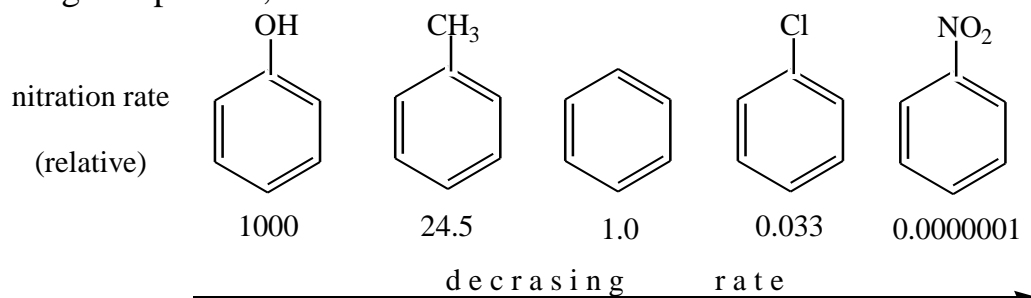

Taking benzene as the standard, we see that some substituents (for example, OH and CH_3) speed up the reaction, and other substituents (Cl and NO_2) retard the reaction. We know from other evidence (Chapter 3.3) that hydroxyl and methyl groups are electron donating substituents while chloro and nitro groups are electron withdrawing substituents.

These observations support the electrophilic mechanism for substitution. If the reaction rate depends on the electrophilic attack on the aromatic ring, the substituents that donate electrons to the ring will increase its electron density, hence speed up the reaction; substituents that withdraw electrons from the ring will decrease electron density in the ring and therefore slow down the reaction.

The experimental evidence proved that such substituents determine:

- the rate of substitution — whether it will occur slower or faster than for benzene;

- the position taken by a new substituent.

In general, substituents fall into one of two categories.

The electron-donating substituents exhibiting positive inductive (+I) or positive resonance (+R) effects increase electron density of a benzene ring and are considered to be **ring-activating substituents**. Such substituents direct the new electrophiles at ortho- and para positions of an aromatic ring:

The bright examples of **ortho, para-directing groups** are:

- alkyl radicals ($-\text{CH}_3$, $-\text{C}_2\text{H}_5$);
- functional groups with unshared electron pairs ($-\text{NH}_2$, $-\text{NHR}$, $-\text{NR}_2$, $-\text{OH}$, $-\text{OR}$, and halogens).

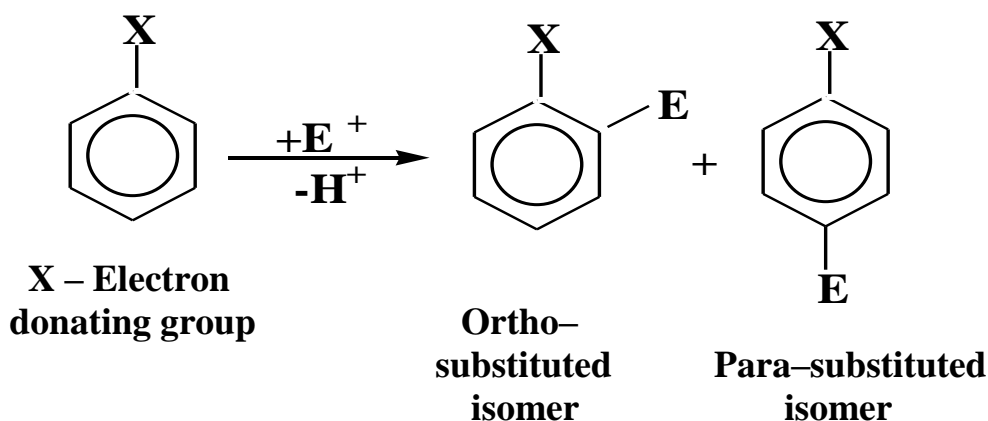

For example, bromination of toluene proceeds much quicker than that of benzene and gives a mixture of ortho-, para-substituted products:

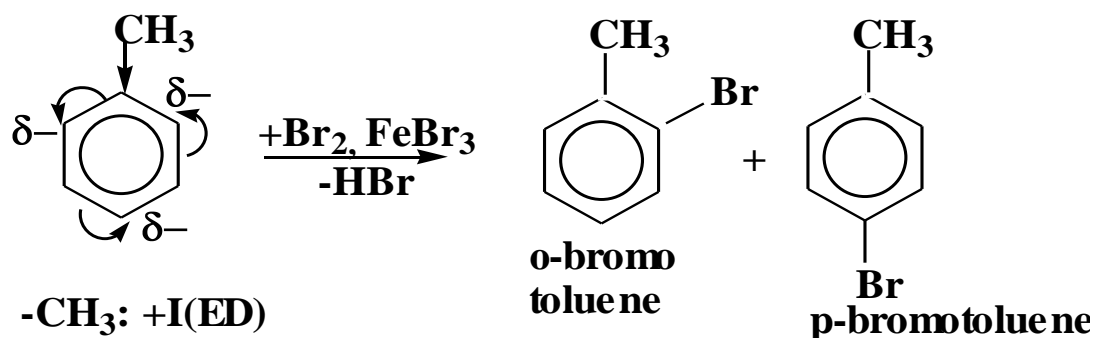

Aniline (phenyl amine) is even more reactive towards electrophiles than toluene, because nitrogen lone electron pair is contributed to the aromatic π -system and highly increases its electron density. Bromination of aniline is very vigorous and rapidly gives 2, 4, 6-tribromoaniline without any catalysts:

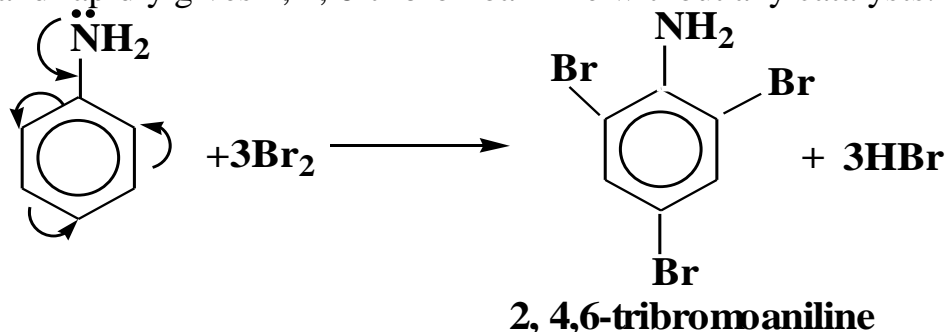

The **electron-withdrawing substituents** exhibiting negative inductive ($-I$) or negative resonance ($-R$) effects decrease electron density of a benzene ring and are considered to be **ring-deactivating substituents**. Such substituents direct the new electrophiles at meta-positions of an aromatic ring:

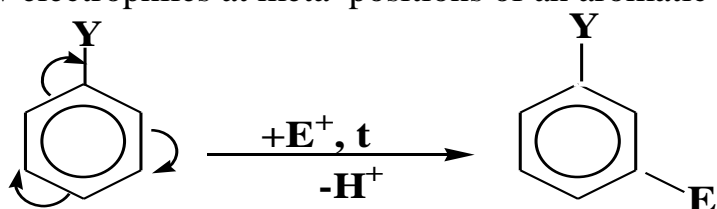

The bright examples of **meta-directing groups** are $-\text{NO}_2$, $-\text{SO}_3\text{H}$, $-\text{CN}$, $-\text{CHO}$; $-\text{COOH}$. For example, bromination of benzoic acid proceeds slowly and gives only one main product — meta-bromobenzoic acid

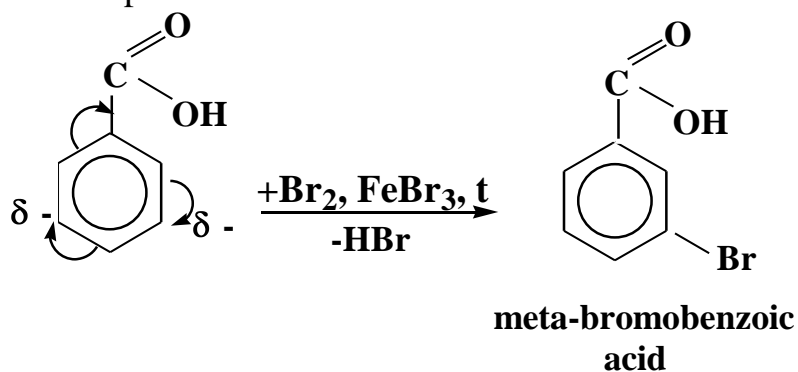

8.3. Electrophilic Aromatic Substitution in Polycyclic Aromatic Hydrocarbons

Polycyclic aromatic hydrocarbons are contained in coal tar, which is a by-product of coke production by heating coal in the absence of air. Naphthalene, C_{10}H_8 , was the first pure compound to be obtained from the higher boiling fractions of coal tar. It was isolated because it sublimates from the tar as a beautiful colorless crystalline solid, mp 80°C . Naphthalene is a planar molecule with two fused benzene rings. The two rings share two carbon atoms:

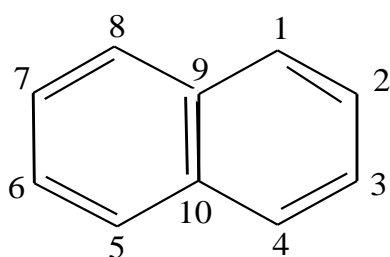

naphthalene

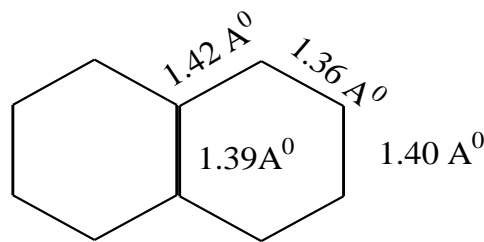

bond lengths in
naphthalene

The bond lengths in naphthalene are not all identical, but they all approximate the bond length in benzene (0.139 nm). Although it has two six-membered rings, naphthalene has resonance energy somewhat less than twice that of benzene, about 60 kcal/mol. Because of its symmetry, naphthalene has two sets of equivalent carbon atoms: C-1, C-4, C-5, and C-2, C-3, C-6, and C-7. Like benzene, naphthalene undergoes electrophilic substitution reactions (halogenation, nitration, and so on), usually under somewhat milder conditions than benzene. Although two monosubstitution products are possible, substitution at C-1 usually predominates:

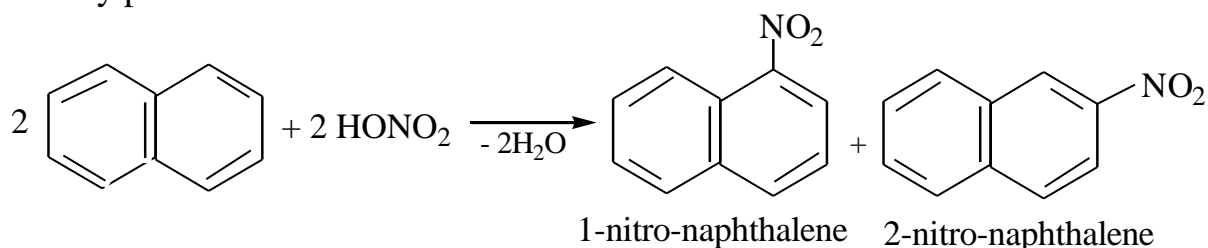

8.4. Electrophilic Substitution in Heteroaromatic Compounds

Electrophilic substitution of heteroaromatic compounds depends upon a nature of heteroatoms in their molecules.

In pyridine molecule the electrons withdrawal by the nitrogen atom makes the ring partially positive and therefore not receptive to attack by electrophiles, which are also positive. Thus nitrogen atom in pyridine molecule deactivates aromatic ring toward S_E reactions and directs substituents into β -position:

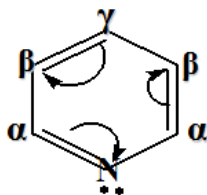

Due to this pyridine is very resistant to aromatic electrophilic substitution and undergoes reaction only under drastic conditions:

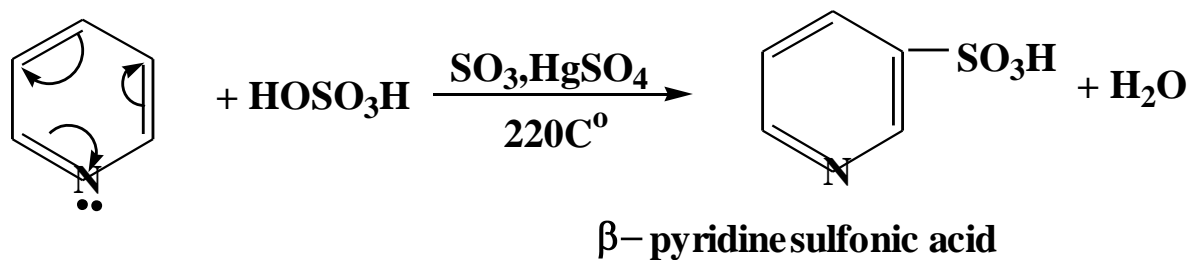

Most bioactive pyridine derivatives also contain substituents at β -position:

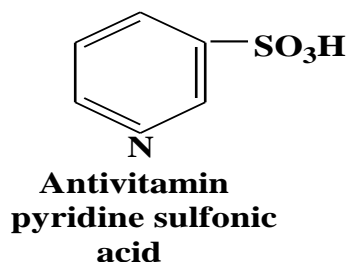
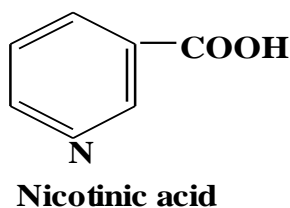

In five-membered aromatic rings such as furan, pyrrole and thiophene, heteroatoms contribute two electrons into aromatic π -system; therefore electron density of such substrates is greater than that of benzene. Thus five-membered aromatic cycles exhibit higher reactivity to S_E reactions than benzene. Each reacts predominantly at α -position:

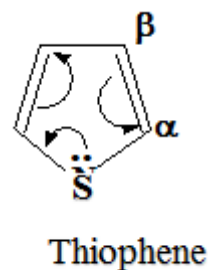
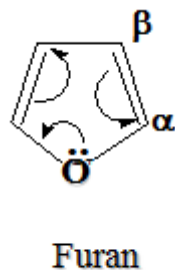
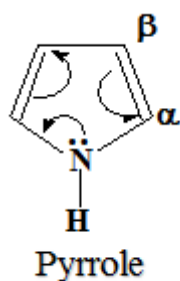

For example, pyrrole bromination results in formation of α -bromo pyrrole:

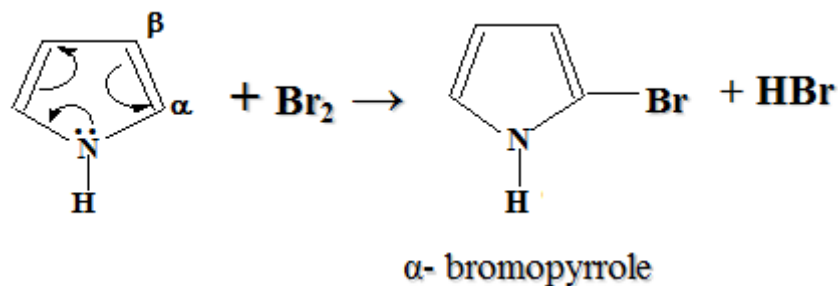

When selecting the reactants is necessary to consider instability of the pyrrole and furan ring in strongly acidic medium. They are defined as acidophobic compounds thus and their sulfonation and nitration requires special non-acidic reagents. Thus, pyridine sulfur trioxide is applied for pyrrole sulfonation:

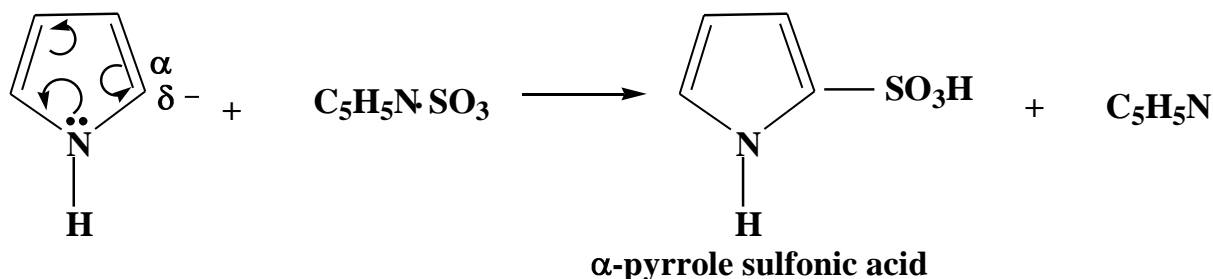

Acetyl nitrate which is anhydride of acetic and nitric acids is applied for pyrrole nitration:

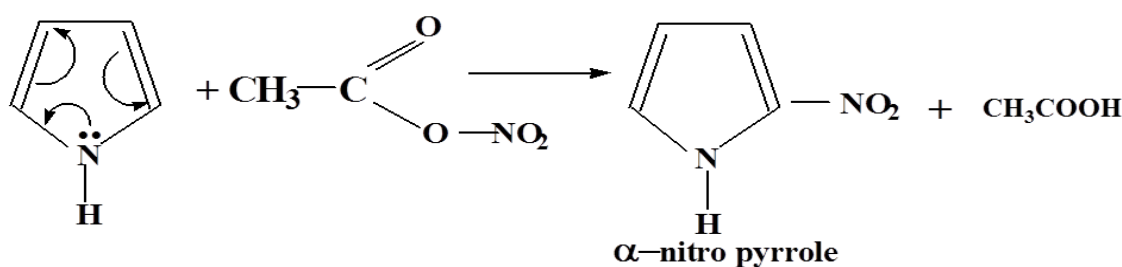

Thus the acidic medium is excluded at all stages of sulfonation and nitration of pyrrole.

8.5. Exercises for the Self-Control

- Write out all steps in the mechanism for the reaction of:
 - toluene + nitric acid (H_2SO_4 as a catalyst);
 - benzoic acid + isopropyl chloride (AlCl_3 as a catalyst).
- Using benzene as the only aromatic starting material, devise a synthesis for each of the following:
 - p-chloronitrobenzene;
 - p-toluenesulfonic acid;
 - p-nitroethylbenzene.
- Which compound is more reactive toward electrophilic substitution reactions?
 - phenol or benzoic acid;
 - benzene or toluene;
 - pyrrole or pyridine.
- Write all the steps in the mechanism of aniline nitration. Name the mechanism. Which compound is more reactive towards electrophilic substitution: aniline or benzoic acid? Why?

CHAPTER 9

NUCLEOPHILIC SUBSTITUTION AND ELIMINATION IN COMPETITION

After reading this chapter, you should be able to:

- describe distribution of electron density in molecules of aliphatic compounds: alkyl halides, alcohols, thiols, amines; define nucleophilic, electrophilic and CH-acidic reactionary centers in them;
- give the schemes for nucleophilic aliphatic substitution and elimination reactions; explain the term “reactions in competition”;
- discuss a mechanism of nucleophilic substitution reactions; define leaving and incoming groups; give examples of such reactions *in vivo*;
- describe a mechanism of elimination reactions; discuss all elementary steps involved in dehydration of alcohols; define Saytzeff’s rule.

9.1. General Concepts

Nucleophilic substitution (S_N) and elimination (E) reactions may occur in one molecule but at different reactionary centers. Both promoted by nucleophilic reagents they are reactions in competition. Alkyl halides, alcohols, thioalcohols, amines and some other organic substances are substrates for such reactions. The reactionary centers in their molecules may be represented by the following scheme (figure 9.1):

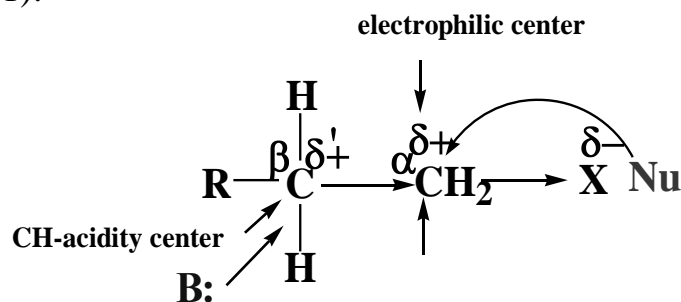

Figure 9.1 — The reactionary centers in organic molecules with saturated carbon atom

In figure 9.1. **X** is an electron-withdrawing group, which attracts electron density toward itself. Such groups contain electronegative atoms (O, N, S), or they are halogens.

When a nucleophile attacks an electrophilic center in a substrate molecule nucleophilic substitution occurs, but when it attacks CH-acidic center — elimination predominates (figure 9.2).

Generally substitution pathways predominate in the competition, because they require fewer bond changes and have fewer conformational requirements. Therefore, substitution reactions are usually more energetically favorable.

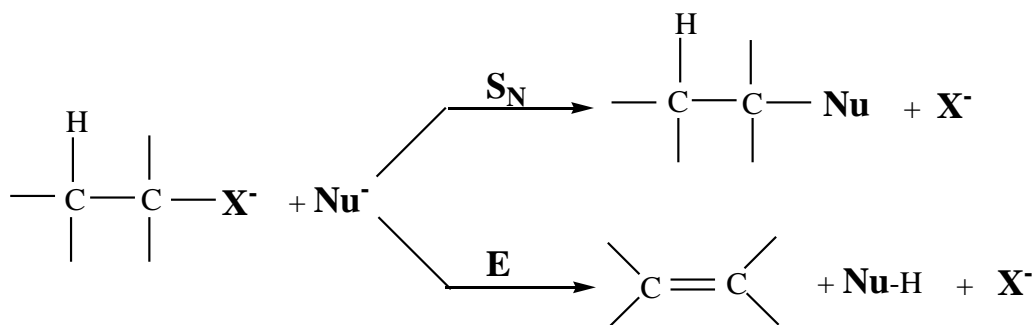
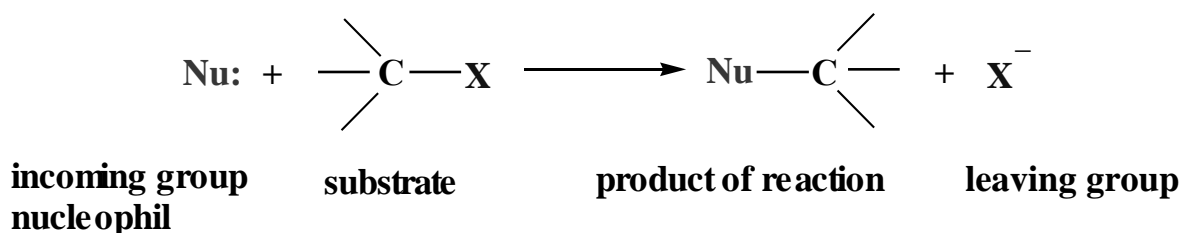

Figure 9.2 — Nucleophilic substitution and elimination in competition

A substitution reaction is a chemical reaction in which one constituent of an organic compound is replaced or substituted by a functional group from a second reactant. An aliphatic nucleophilic substitution reaction is written in a following way:



S_N displacement occurs with inversion of configuration. The three groups attached to sp^3 carbon invert, somewhat like the umbrella caught in a strong wind.

Leaving group is an atom or group of atoms that leaves from a substrate (along with a pair of electrons) in a nucleophilic substitution reaction. They fall into two categories: good leaving and poor leaving (figure 9.3)

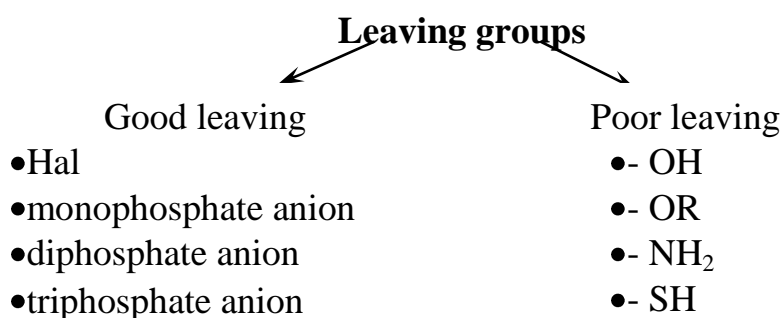

Figure 9.3 — Classification of leaving groups

Good leaving groups are easily displaced by other nucleophilic particles while poor leaving groups can be displaced after their protonation. The protonation of leaving groups is performed in order to convert poor leaving groups into good leaving.

Given below are the principal substrates for S_N reactions.

| Substrates | Bond | Leaving groups |
|-------------------|--|--|
| | $\overset{\delta+}{\text{C}} \rightarrow \overset{\delta-}{\text{X}}$ | |
| Alcohols | $\begin{array}{c} \delta+ \\ \diagup \\ \text{C} \\ \diagdown \end{array} - \overset{\delta-}{\text{OH}}$ | H_2O |
| Ethers | $\begin{array}{c} \delta+ \\ \diagup \\ \text{C} \\ \diagdown \end{array} - \overset{\delta-}{\text{OR}}$ | R-OH |
| Alkyl Halides | $\begin{array}{c} \delta+ \\ \diagup \\ \text{C} \\ \diagdown \end{array} - \overset{\delta-}{\text{Hal}}$ | $\text{Cl}^-, \text{Br}^-, \text{I}^-$ |
| Phosphoric esters | $\begin{array}{c} \delta+ \\ \diagup \\ \text{C} \\ \diagdown \end{array} - \overset{\delta-}{\text{O}} \begin{array}{c} \text{O} \\ \\ \text{P} \\ \\ \text{OH} \end{array} - \text{OH}$ | $\begin{array}{c} \text{O} \\ \\ \text{O}^- - \text{P} - \text{OH} \\ \\ \text{OH} \end{array}$ |
| Amines | $\begin{array}{c} \delta+ \\ \diagup \\ \text{C} \\ \diagdown \end{array} - \overset{\delta-}{\text{NH}_2}$ | NH_3 |
| Thiols | $\begin{array}{c} \delta+ \\ \diagup \\ \text{C} \\ \diagdown \end{array} - \overset{\delta-}{\text{SH}}$ | H_2S |

9.2. Nucleophilic Aliphatic Substitution

Mechanism of Nucleophilic Substitution can be represented by the following scheme:

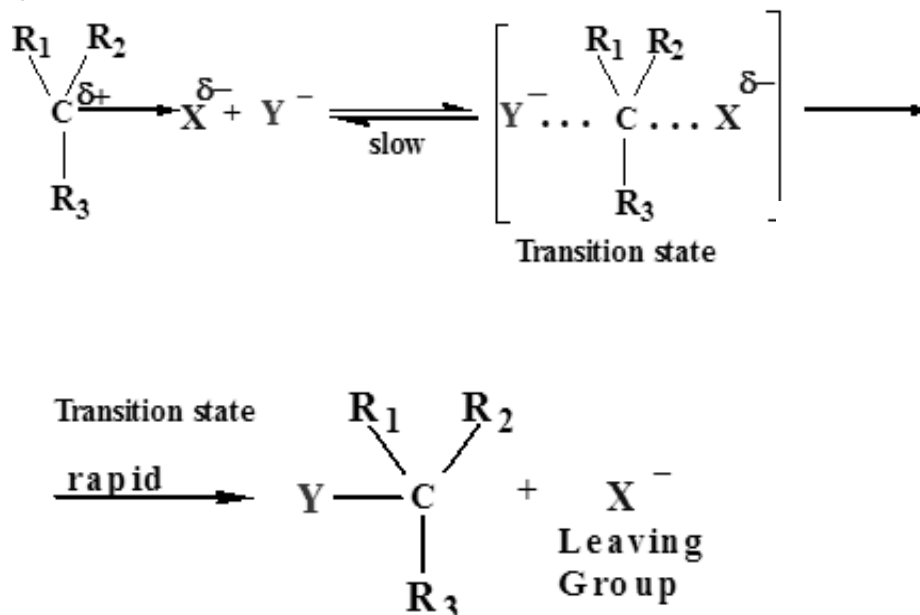

At the transition state the nucleophile and the leaving group are both partly bonded to the carbon at which substitution occurs. As the leaving group departs with the electron pair, the nucleophile supplies another electron pair to the carbon atom.



Aliphatic nucleophilic substitution occurs *in vivo*. A bright example of such reactions is biosynthesis of S-adenosyl methionine, which plays an essential role in vitamin B₁₂ production and calamine transformation into choline.

Vitamin B₁₂, sometimes referred to as cobalamin, is one of the eight B vitamins. As a water soluble vitamin, the human body can not store it, so it should be consumed on a daily basis. Vitamin B₁₂ assists the nervous system and boosts brain functioning. It is most commonly found in animal products such as shellfish, poultry, eggs and milk.

S-Adenosylmethionine Biosynthesis

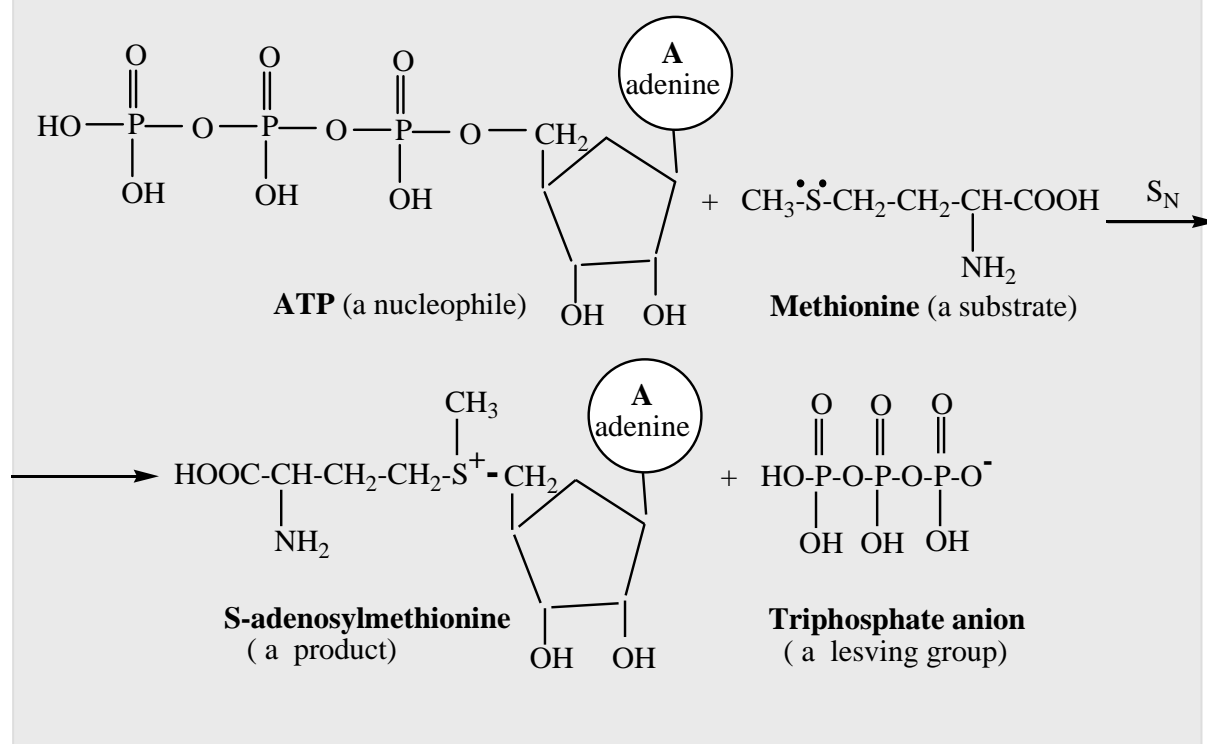

When 2-chloropropanoic acid is treated with aqueous sodium hydroxide solution the following reaction occurs:

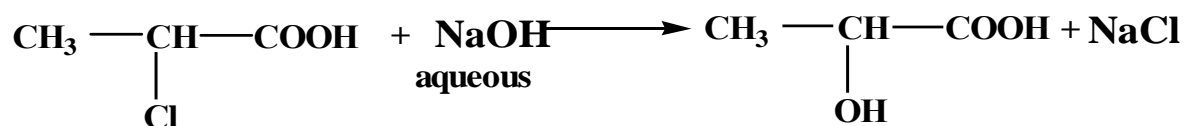

Lactic acid

Its mechanism is represented by the scheme:

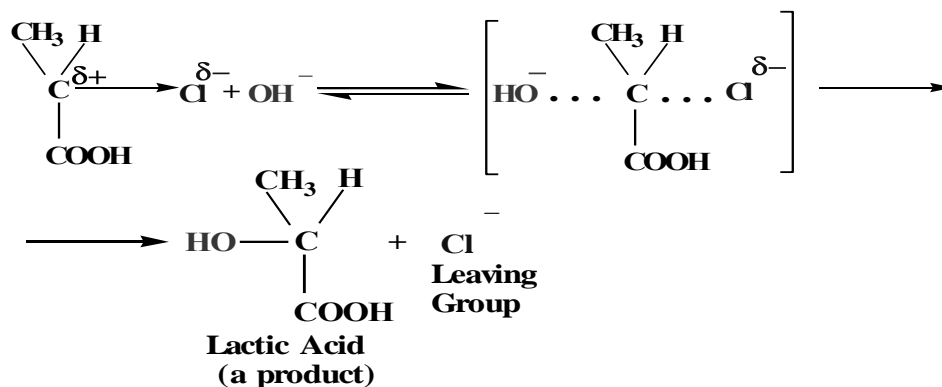

Nucleophilic substitution in alcohols, thiols and amines is easy going in acidic medium because protonation of their poor leaving groups convert them into good leaving:

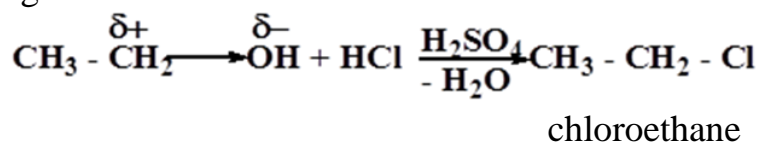

Its mechanism involves three consecutive steps: (a) a step of protonation, (b) a step of water elimination and (c) a step of chloride anion addition:

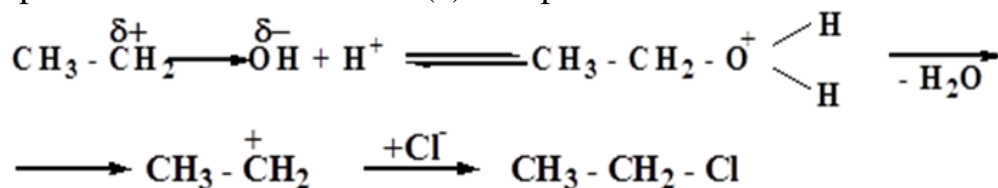

Nucleophilic substitution reactions are applied in chemical industry to prepare a wide range of substances. Thus alkyl halides can continue to be modified to form multi-substituted compounds (figure 9.4).

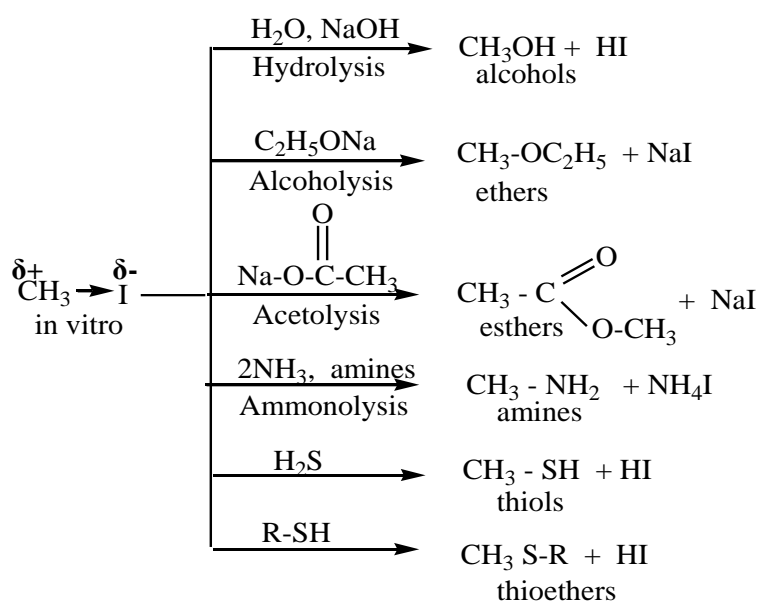
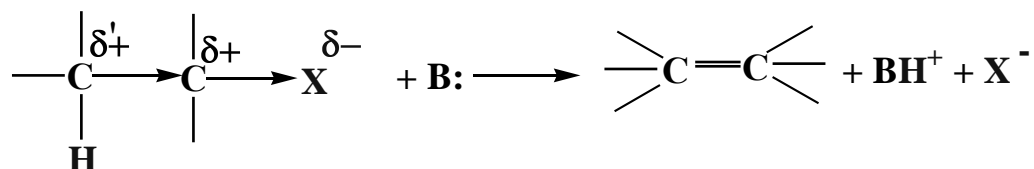

Figure 9.4 — Nucleophilic substitution reactions in alkyl halides

9.3. Elimination Reactions

An **elimination reaction** is a reaction when two atoms or groups of atoms leave a substrate, giving the product a multiple bond. The atoms may leave the substrate from adjacent carbons (β -elimination) or from carbons some distance apart.

β -Elimination Reaction (E)



For example, when 2-bromoethane is treated with alcohol sodium hydroxide solution the following reaction occurs:

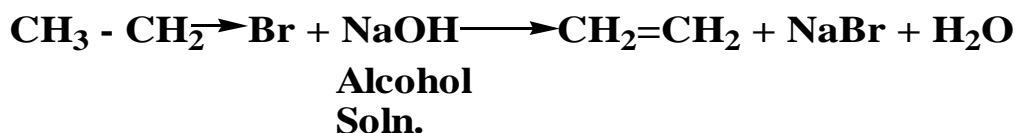

The mechanism of a given reaction can be represented by a following scheme:

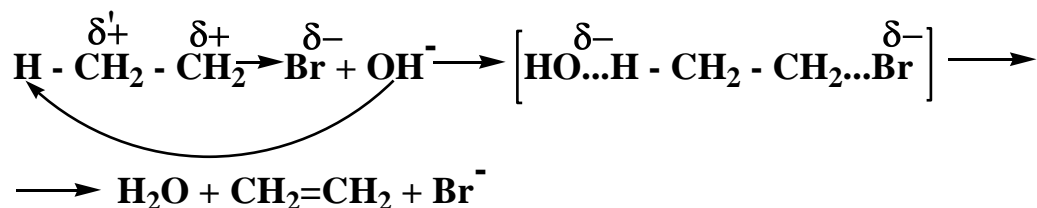

Elimination of water (dehydration) is wide spread in nature. Dehydration plays an important role in metabolic processes. Acid catalyzed dehydration of isopropyl alcohol is bright example of such reactions:

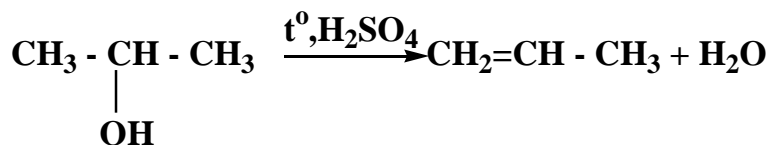

The mechanism of dehydration involves three steps.

Step 1. Protonation of a hydroxyl group, which results in oxonium cation formation:

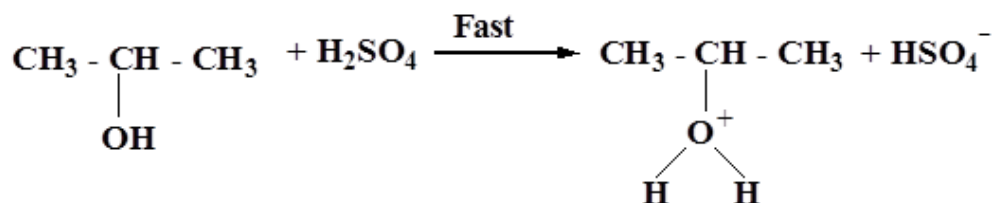

Step 2. Elimination of water results in a carbocation formation:

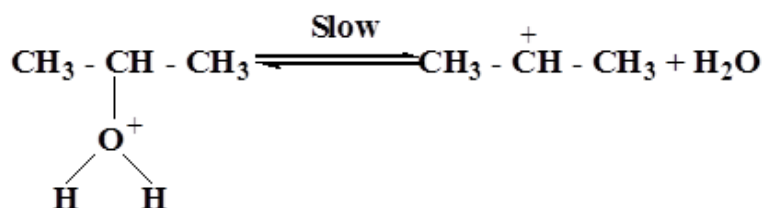

Step 3. Loss of a proton:

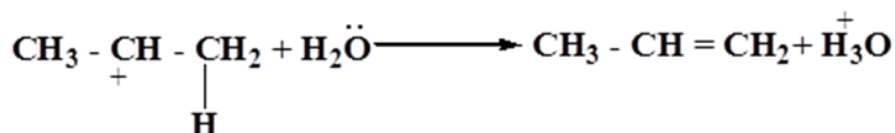

Acid catalyzed dehydration reactions of secondary alcohols generally follow the Saytzeff's rule. Hydrogen is removed from the least hydrogenated carbon atom. For example, butane-2 is the only product of butanol-2 dehydration:

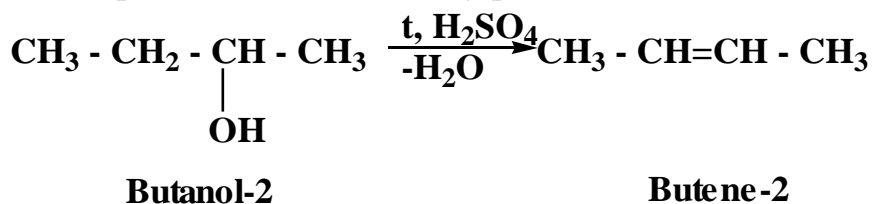

Insecticides and Herbicides

Weeds create formidable problems for agriculture. They consume nutrients and moisture needed by crops. They also rob crops of sunlight and space, thus reducing crop yields. U.S. agricultural production is diminished by about 10% because of weeds. The annual financial loss is about \$12 billion, and an additional \$6 billion is spent annually on weed control.

One way to control weeds is through the use of herbicides, many of which are polyhalogenated compounds. About 85 to 90 % of U.S. corn, soybean, cotton, peanut, and rice acreage are sprayed with herbicides to control weeds. Some are sprayed before the crop is planted; others are applied after planting but before emergence of the crop, and still others are applied to the weed foliage itself. The rising world population makes increasing demands on food production and, ultimately, on herbicide use to meet that demand. Although most herbicides are used for this purpose, some are also employed for industrial purposes — along railway and power line rights of way, on roadsides, on rangeland, in vacant lots, and so on — as well as for lawns and gardens.

Farmers have used weed killers for many years; common salt was used for this purpose even in ancient times. Before World War II, most chemical herbicides were not very selective (they killed weeds but also damaged crops) and had to be used; in large quantities per acre of land.

The breakthrough came with the discovery that 2, 4-dichlorophenoxyacetic acid (2, 4-D) killed broadleaf weeds but allowed narrow leaf plants to grow unharmed and in greater yield. In addition, only 0.25 to 2.0 pounds were needed per acre (compared to more than 200 pounds per acre for inorganic herbicides such as sodium chlorate).

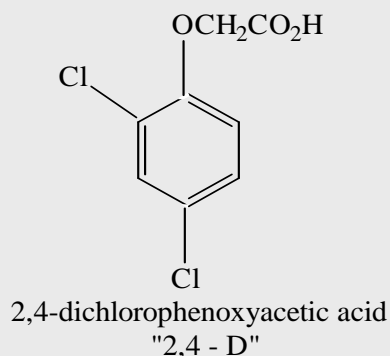

A new class of herbicides recently developed, by DuPont represents a major breakthrough. One example is Glean™.

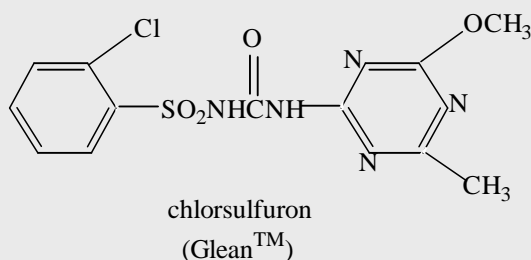

Clean is effective against a broad spectrum of weeds in cereal grains (wheat, barley, and oats) at the remarkably low application level of *less than one ounce per acre*. At present, at least a dozen herbicides of this type are marketed commercially, serving unique needs of farmers.

Because of the danger that, even in very low concentrations, pesticides may have harmful side effects and become environmental pollutants, and because agriculture without pesticides can no longer meet human needs, still other approaches to the important problem of pest control are being researched. For example, many plants have natural defense mechanisms against predators and pathogens; they produce substances that shield them from harm. These substances may kill harmful bacteria, repel insects or interfere with their reproductive cycles, prevent fungal spores from germinating, and in many other ways act as natural protection for a plant.

One new approach to pesticides is to isolate these natural defense substances, learn how they work, and then either use these materials themselves (rotenone, the principal insecticidal constituent of derris root, is a well-known example) or design synthetic pesticides based on their structures. One, recent example is derived from the neem tree, native to arid regions of India, Pakistan, and Sri Lanka.

It has been known for centuries that areas where it grows are virtually free insects, nematodes, and plant diseases. Extracts of its seeds provide effective protection insects, against more than **100** crop pests, aphids, and boll weevils; and a pesticide based on these extracts has recently been approved for limited use.

The achievements modern agriculture and the feeding of the ever-growing world population would not be possible without the herbicides that chemists and other scientists have developed.

Alexander Saytzeff (2 July 1841 – 1 September 1910) was a Russian chemist from Kazan. He worked on organic compounds and proposed Saytzeff's rule, which predicts the product composition of an elimination reaction. His research was primarily concerned with the development of organo-zinc chemistry and the synthesis of alcohols.



Dehydration of malic acid is an example of dehydration *in vivo*:

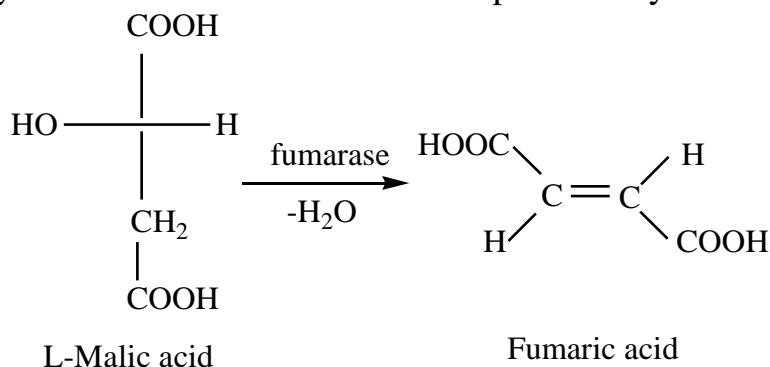

9.4. Exercises for the Self-Control

1. Complete the equations of following S_N reactions. Name the products.

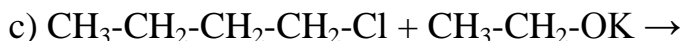
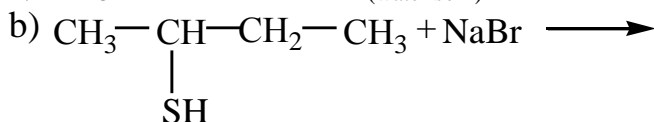
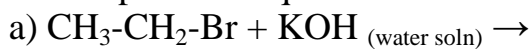

Specify good and poor leaving groups in substrates' molecules.

2. Write equations to show how methyl iodide could be converted to methyl cyanide CH_3CN and dimethyl sulfide $\text{CH}_3\text{-S-CH}_3$. Name the mechanism of these reactions.

3. Write the equation for the reaction of n-propyl chloride with potassium hydroxide KOH in aqueous solution. Show the steps in the mechanism for this reaction.

4. Write out all the steps in the mechanism of a chemical reaction between isopropyl alcohol and HBr. Name the mechanism of this reaction.

5. Benzyl iodide $C_6H_5CH_2I$ is a strong lachrymator. Devise the synthesis for benzyl iodide from benzyl alcohol $C_6H_5CH_2OH$ and hydro iodine acid. Write out all the steps in the mechanism, showed how a product is formed.

6. Write an equation for butanol-2 dehydration in acidic medium. Name the product the reaction. Show all steps in the mechanism of this reaction.

CHAPTER 10 ALDEHYDES AND KETONES

After reading this chapter, you should be able to:

- define aldehydes and ketones;
- discuss their classification and nomenclature;
- describe chemical properties of aldehydes and ketones;
- define the main steps in nucleophilic addition to carbonyl group (A_N).

10.1. General Characteristics of Aldehydes and Ketones

Aldehydes and ketones are carbonyl compounds, containing carbonyl functional group:

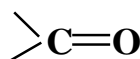

Aldehydes have at least one hydrogen atom attached to the carbonyl carbon atom. The remaining group may be another hydrogen atom or any organic group. General formula for aldehydes may be represented as:

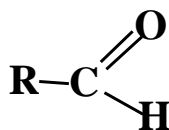

According to the radicals three types of aldehydes are distinguished:

- saturated

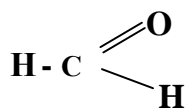

Methanal,
formaldehyde

- unsaturated

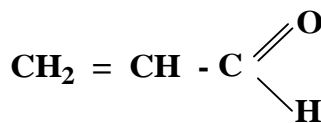

Propenal

- aromatic

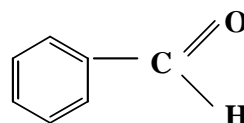

Benzaldehyde

In ketones the carbonyl carbon is connected to two radicals. General formula for ketones is:

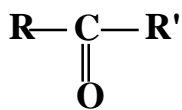

According to the radicals ketones are:

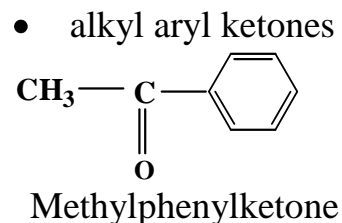
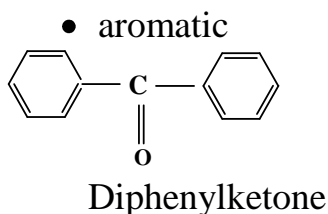
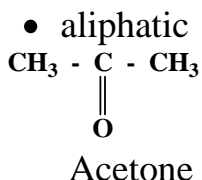

Aldehydes and ketones occur widely in nature. Many of them have pleasant odors and flavors and are used for these properties in perfumes and other consumer products (soaps, bleaches, and air fresheners, for example). The gathering and extraction of these fragrant substances from flowers, plants and animal glands is extremely expensive, however. Chanel № 5, introduced in to the perfume market in 1921, was the first fine fragrance to use synthetic organic chemicals. Structural formulas and namings of some aldehydes and ketones are given in Table 10.1.

Table 10.1 — Structural formulas and namings of some aldehydes and ketones

| Formulas | Systematic names | Common names |
|---|------------------|--------------------|
| $\begin{array}{c} \text{H} - \text{C} \begin{array}{l} \nearrow \text{O} \\ \searrow \text{H} \end{array} \end{array}$ | Methanal | Formaldehyde |
| $\begin{array}{c} \text{CH}_3 - \text{C} \begin{array}{l} \nearrow \text{O} \\ \searrow \text{H} \end{array} \end{array}$ | Ethanal | Acetaldehyde |
| $\begin{array}{c} \text{CH}_3 - \text{CH}_2 - \text{C} \begin{array}{l} \nearrow \text{O} \\ \searrow \text{H} \end{array} \end{array}$ | Propanal | Propionic aldehyde |
| $\begin{array}{c} \text{CH}_3 - \text{CH}_2 - \text{CH}_2 - \text{C} \begin{array}{l} \nearrow \text{O} \\ \searrow \text{H} \end{array} \end{array}$ | Butanal | Butyric aldehyde |
| $\begin{array}{c} \text{CH}_3 - \text{CH}_2 - \text{CH}_2 - \text{CH}_2 - \text{C} \begin{array}{l} \nearrow \text{O} \\ \searrow \text{H} \end{array} \end{array}$ | Pentanal, | Valeric aldehyde |

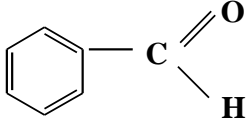
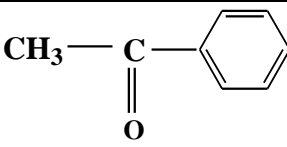
| Formulas | Systematic names | Common names |
|--|----------------------|-------------------|
| $\text{CH}_2 = \text{CH} - \text{C} \begin{array}{l} \text{// O} \\ \text{\textbackslash H} \end{array}$ | Propenal | Acroleine |
| $\text{CH}_3 - \text{CH} = \text{CH} - \text{C} \begin{array}{l} \text{// O} \\ \text{\textbackslash H} \end{array}$ | Butene-2-al | Crotonic aldehyde |
|  | Benzaldehyde | Benzoic aldehyde |
| $\text{CH}_3 - \text{C} \begin{array}{c} \text{// O} \\ \text{\textbackslash O} \end{array} - \text{CH}_3$ | Propanone | Acetone |
|  | Methyl phenyl ketone | Acetophenone |

Among some common aldehydes and ketones are: *formaldehyde*, which is a gas (bp-21°C), normally supplied as a 37 % aqueous solution called *formalin*. Formalin is used as a disinfectant and preservative, but most formaldehyde is used in the manufacture of plastics, building insulation and plywood; *acetaldehyde*, which is a colorless liquid (bp 20°C) that is applied for acetic acid production and production of butanol-1 and other commercial chemicals; *acetone* is the simplest ketone which is an excellent solvent for many organic substances (resins, paints, dyes, and nail polish).

To best understand the reactions of aldehydes and ketones we must first appreciate the structure and properties of the carbonyl group. Carbonyl carbon is sp^2 -hybridized thus three atoms attached to it lie in a plane with bond angles 120° . The carbon-oxygen double bond consists of a sigma-bond and a pi-bond. Oxygen is much more electronegative than carbon, therefore the electrons in the C=O bond are shifted to the oxygen, producing a highly polarized bond. As the result of such a shift oxygen carries partial negative charge thus being a *nucleophilic center* of a molecule. Carbonyl carbon carries a partial positive charge thus being an *electrophilic center* of a molecule. α -Carbon that carries a partial electric charge that is smaller than a charge on a carbonyl carbon is defined as CH-acidic center. The reactionary centers in aldehydes and ketones molecules are represented at the following scheme:

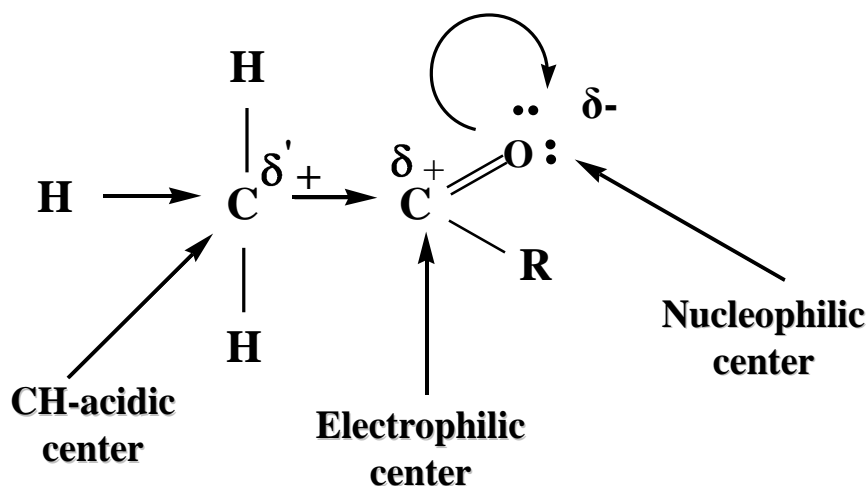

10.2. Nucleophilic Addition to Carbonyl Group – A_N

As a consequence of C=O bond polarization, most carbonyl reactions involve nucleophilic attack at the carbonyl carbon. The general scheme for nucleophilic addition to carbonyl compounds is:

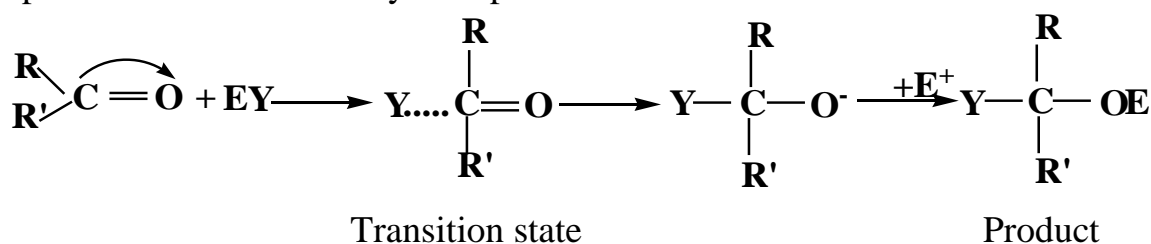

Carbonyl carbon which is an electrophilic center in carbonyl compounds molecules, attract nucleophilic particles while electrophilic particles add to oxygen. The greater is positive charge on carbonyl carbon, the higher is reactivity of substrates toward *nucleophilic addition* reactions.

In general, ketones are less reactive than aldehydes toward nucleophiles. There are two main reasons for this reactivity difference. The first reason is *steric*. The carbonyl carbon is more crowded in their molecules than that in aldehydes:

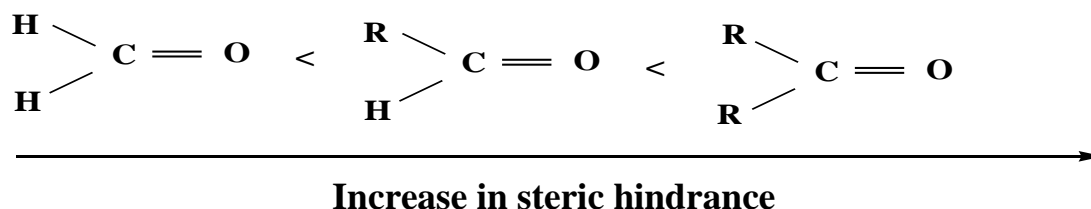

The second reason is *electronic*. As we have already seen in Chapter 3.3 alkyl groups are electron-donating compared to hydrogen. They therefore tend to neutralize the partial positive charge on the carbonyl carbon, decreasing its reactivity toward nucleophiles. Ketones have two such alkyl groups; aldehydes

have only one. If however the attached groups are strongly electron-withdrawing (contain halogens, for example), they can have the opposite effect and increase carbonyl reactivity toward nucleophiles:

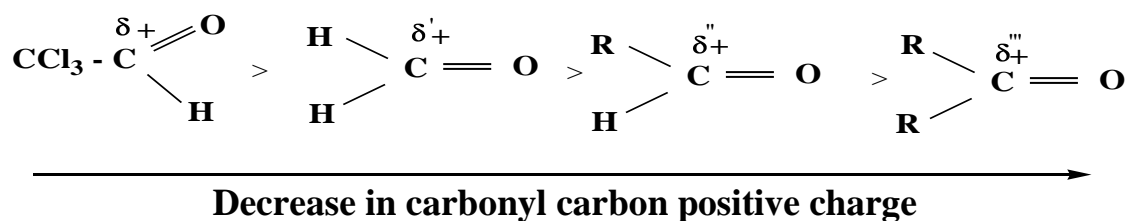

Considered below are chemical reactions occurring according to the A_N mechanism.

Addition of Alcohols (formation of hemiacetals and acetals). The reactions discussed in this section are extremely important because they are crucial to understanding the chemistry of carbohydrates, which we will discuss later.

Alcohols are oxygen nucleophiles. They add to the C=O bond, the OR group becoming attached to the carbon, and the proton becoming attached to the oxygen:

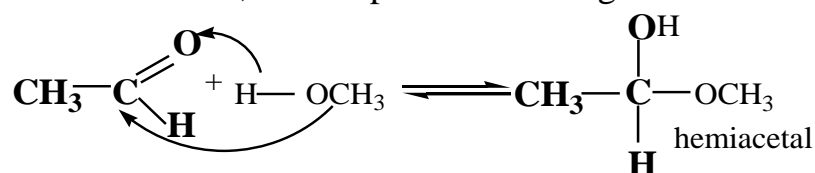

The mechanism of a hemiacetal formation involves three steps:

Step 1. Protonation

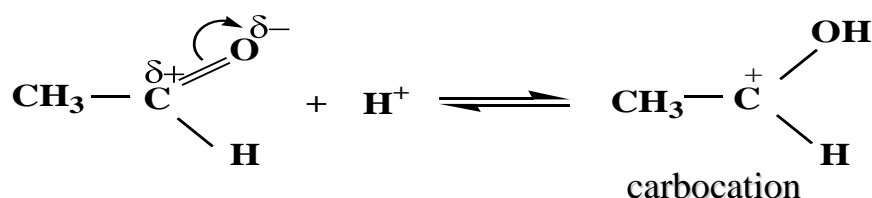

A catalyst increases positive electric charge on the electrophilic center.

Step 2. Addition of an alcohol

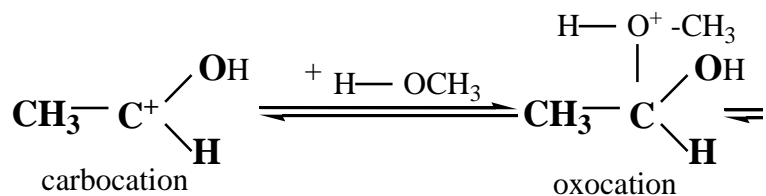

Step 3. Loss of proton (deprotonation)

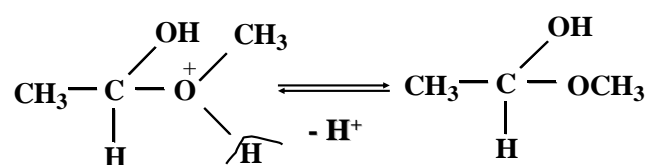

Aldehydes with appropriately located hydroxyl group exist in equilibrium with cyclic hemiacetals, formed by intramolecular nucleophilic addition. For example, 4-hydroxybutanal exists mainly in the cyclic hemiacetal form:

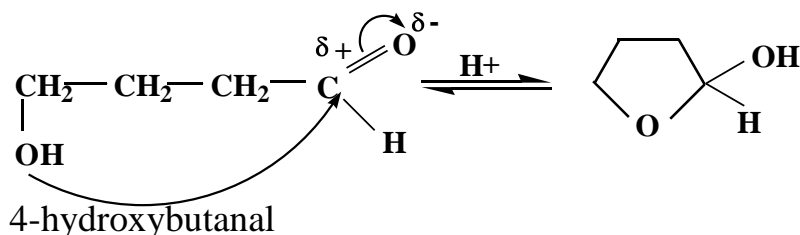

Compounds with a hydroxyl group four or five carbons from the aldehyde group tend to form cyclic hemiacetals because the ring size (five- or six-membered) is relatively strain free. As we will see in Chapter 2.4, these structures are crucial to the chemistry of carbohydrates. For example, glucose is an important carbohydrate that exists as a cyclic hemiacetal.

In the presence of excess alcohol, hemiacetals react further to form acetals. The hydroxyl group of the hemiacetal is replaced by an alkoxy group. Acetals have two ether functions at the same carbon atom. This process is an example of *nucleophilic substitution* reactions:

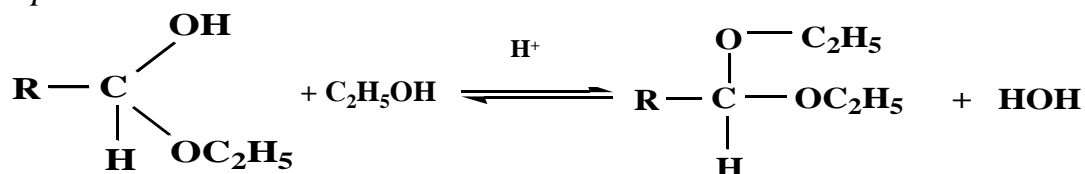

Hemiacetals can be hydrolyzed to their aldehyde (ketone) and alcohol components by treatment with excess water in the presence of an acid catalyst:

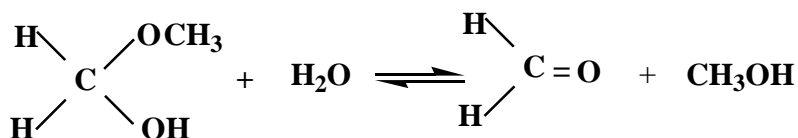

Addition of Water (hydration)

Water, like alcohols, is an oxygen nucleophile and can add reversibly to aldehydes and ketones:

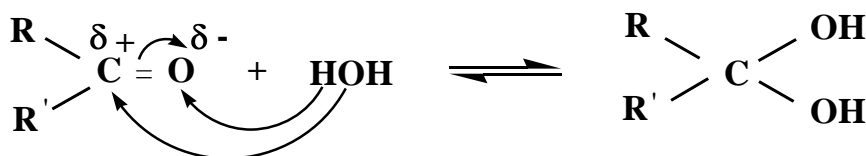

With most aldehydes or ketones, however, the hydrates cannot be isolated because they readily lose water to reform the carbonyl compound. An exception is trichloroacetaldehyde (chloral), which forms a stable crystalline hydrate:

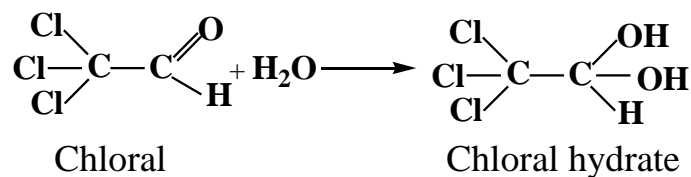

Chloral hydrate is used in medicine as a sedative and in veterinary medicine as a narcotic and anesthetic for horses, cattle, swine and poultry.

Addition of Nitrogen Nucleophiles (addition-elimination reactions)

Ammonia, amines and certain related compounds have a lone electron pair on nitrogen atom and act as nitrogen nucleophiles toward the carbonyl carbon atom. These products of addition are unstable. They eliminate water to form a product with carbon-nitrogen double bond. For example, primary amines react as follows:

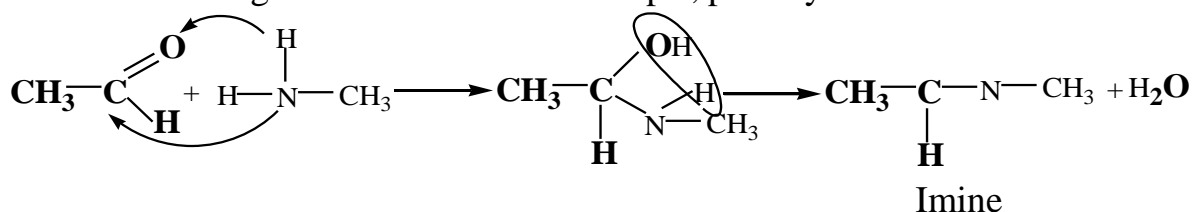

Imines are important intermediates in some biochemical reactions, particularly in binding carbonyl compounds to the free amino groups that are present in most enzymes:

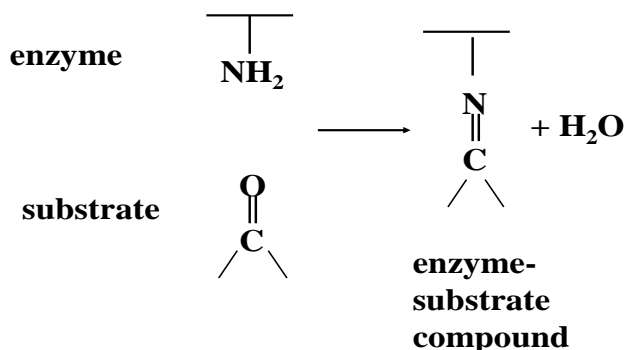

Addition of Hydrogen Cyanide

Hydrogen cyanide adds reversibly to the carbonyl group of aldehydes and ketones to form *cyanohydrins*, compounds with a hydroxyl and a cyano groups attached to the same carbon. A basic catalyst is required:

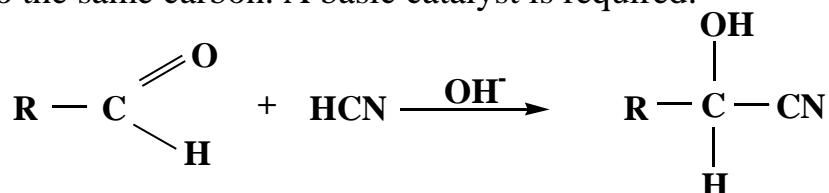

The mechanism of this reaction involves the following steps:

Step 1. Generation of cyanide anion

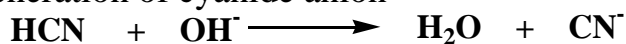

Step 2. Cyanohydrins production:

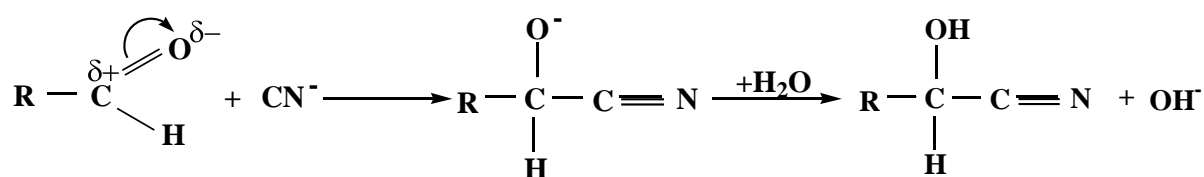

The Aldol Condensation

The aldol condensation is the combination of two aldehydes (ketones) molecules, which occurs when a solution is treated with catalytic amounts of aqueous base. It is an extremely useful carbon-carbon bond-forming reaction which is widespread in nature. It's an important biochemical reaction which takes place in plants' and animals' cells. Only those aldehydes and ketones can be involved in these processes which contain the α -hydrogen. The products of aldol condensation are hydroxyaldehydes named *aldols*.

The simple example of an aldol condensation is the combination of two acetaldehyde molecules, which occurs when a solution of acetaldehyde is treated with catalytic amounts of aqueous base:

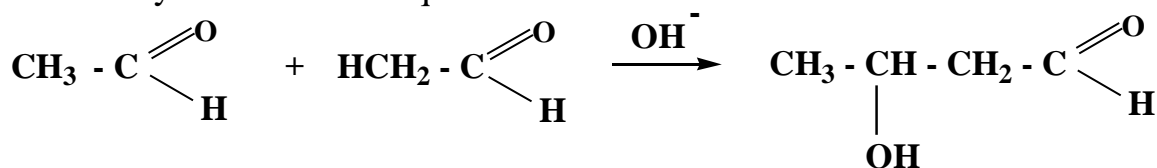

3-hydroxybutanal

Mechanism of aldol condensation involves three steps:

Step 1. The base removes the α -hydrogen to form an enolate anion:

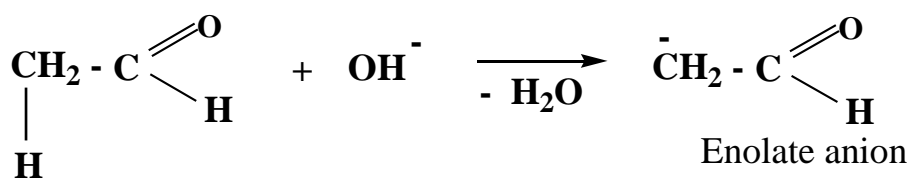

Enolate anions may act as carbon nucleophiles.

Step 2. Enolate anion attacks on a carbonyl carbon of the second aldehydes molecule and forms of an alkoxide anion:

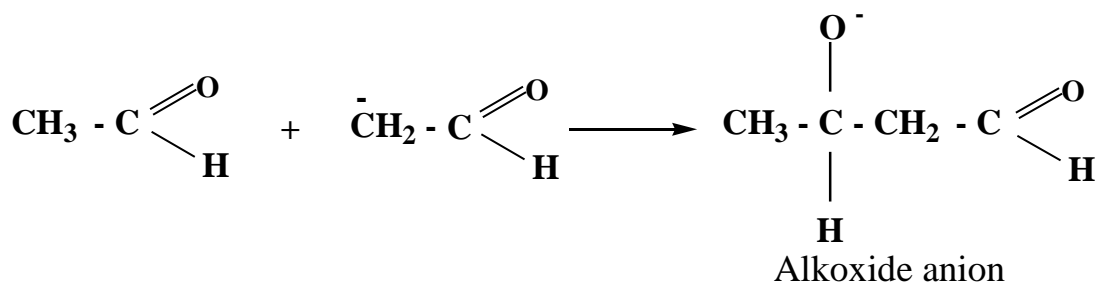

Step 3. An alkoxide anion accepts a proton from the solvent thus regenerating the hydroxide ion needed for the first step:

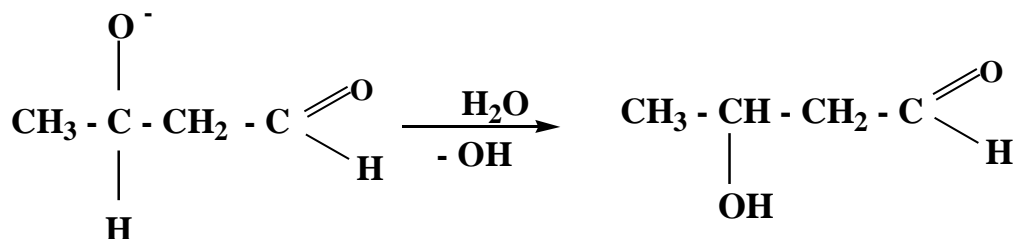

The mixed aldol condensation occurs when the enolate anion of one carbonyl compound can be made to add to the carbonyl carbon of another. Consider, for example, the reaction between acetaldehyde and benzaldehyde, when treated with base. Only acetaldehyde can form an enolate anion since benzaldehyde has no α -hydrogen. When the enolate ion of acetaldehyde adds to the benzaldehyde carbonyl group, a mixed aldol condensation occurs:

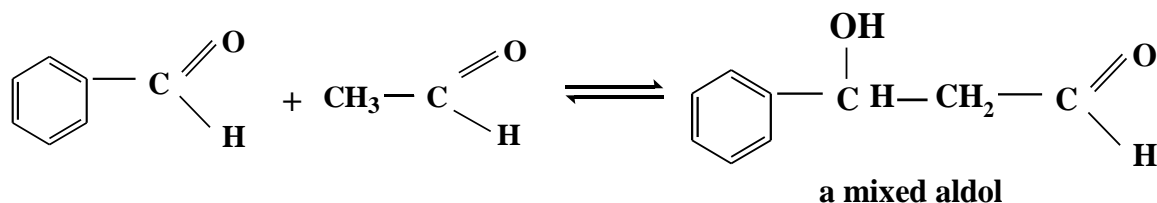

Biosynthesis of citric acid is an example of aldol condensation *in vivo*. It involves oxaloacetic acid and *acetyl coenzyme A*:

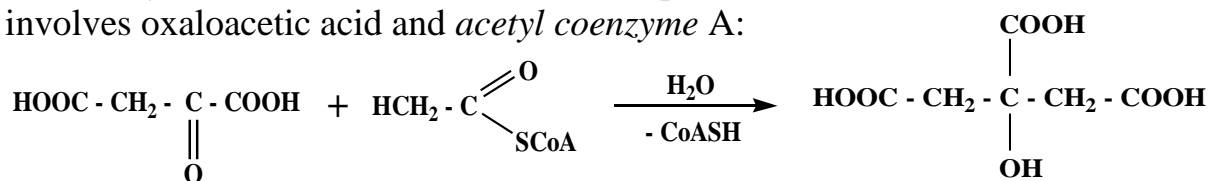

In some cases, the adducts obtained from the aldol condensation can easily be converted to α,β -unsaturated carbonyl compounds, either thermally or under acidic catalysis. The formation of the conjugated system is the driving force for this spontaneous dehydration. For example, 3-hydroxybutanal turns into crotonic aldehyde under heating:

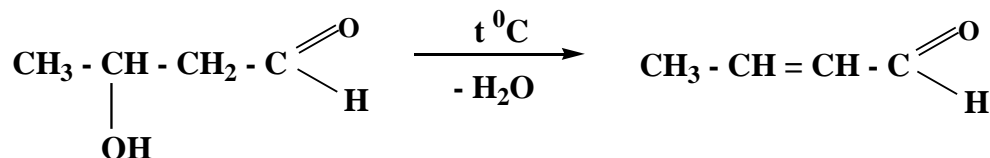

10.3. Reduction and Oxidation of Carbonyl Compounds

Aldehydes and ketones are easily reduced to primary and secondary alcohols respectively. Reduction may be accomplished in many ways, but commonly by metal hydrides. The most common metal hydrides used to reduce carbonyl compounds are lithium aluminum hydride ($\text{Li}[\text{AlH}_4]$) and sodium boron hydride

(Na[BH₄]). The metal-hydride bond is polarized, with the metal positive and hydrogen negative. The reaction therefore involves irreversible nucleophilic attack of the hydride (H⁻) at the carbonyl carbon:

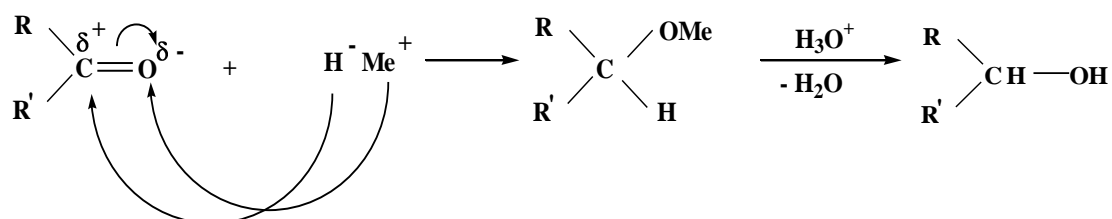

In vivo the coenzyme NAD•H is the principal reducing agent in aldehydes and ketones reduction reactions.

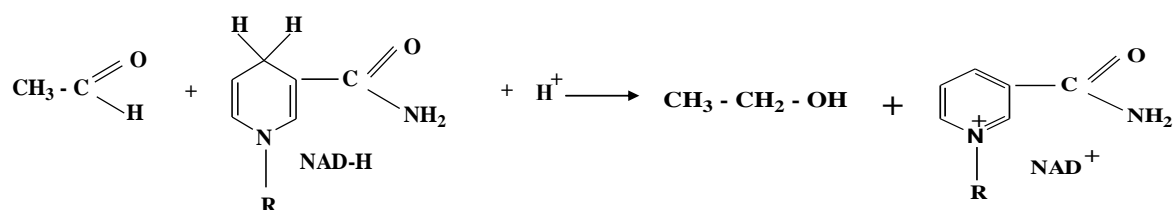

Aldehydes are more easily oxidized than ketones. Oxidation of aldehydes gives acids with the same number of carbon atoms:

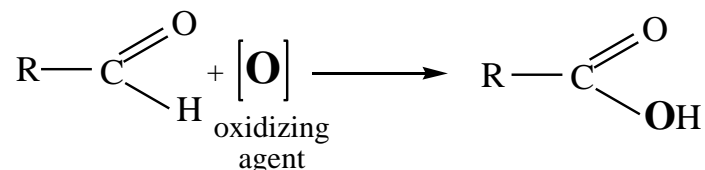

Since the reaction occurs easily, many oxidizing agents, such as KMnO₄, CrO₃, Ag₂O and peracids will work.

A laboratory test that distinguishes aldehydes from ketones takes advantage of their different ease of oxidation. In the *Tollens' Silver Mirror Test*, the silver-ammonia complex ion is reduced to metallic silver:

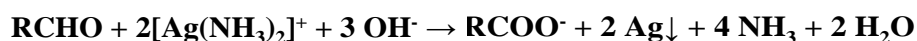

The metallic silver deposits on the glass surface of test-tubes.

In 1853 the Italian chemist S. Cannizzaro noted that when aldehydes that lack an α-hydrogen were treated with strong base, a reaction occurred where half the aldehydes was reduced to corresponding alcohol, and the other half was oxidized to the carboxylic acid. Such reactions are defined as **disproportionation or Cannizzaro reactions**.

For example, benzaldehyde is oxidized into benzoic acid anion and reduces into benzyl alcohol simultaneously:

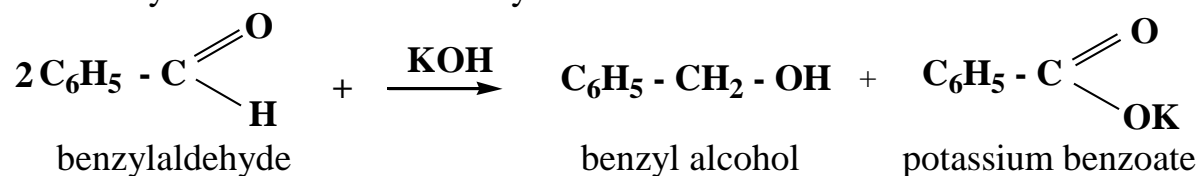

The reaction involves several steps.

Step 1. The reaction begins with nucleophilic attack of hydroxide on the carbonyl carbon:

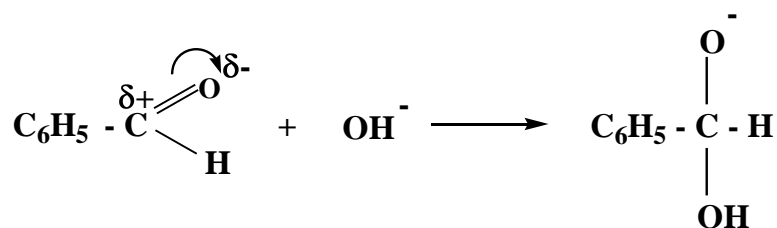

Alkoxide anion

Step 2. In this step the alkoxide anion attacks another molecule of aldehyde, transferring hydride anion:

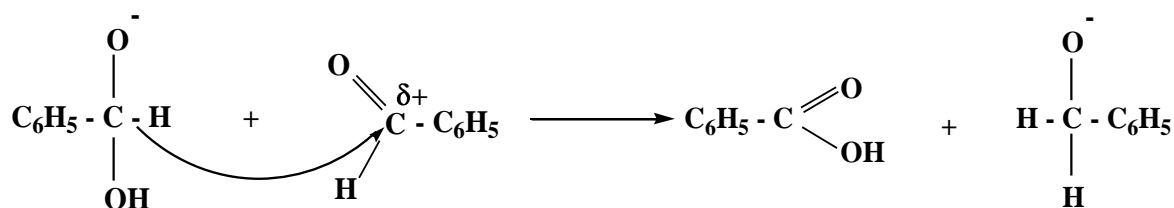

Step 3. In the final step of the reaction, the acid and alkoxide ions exchange a proton:

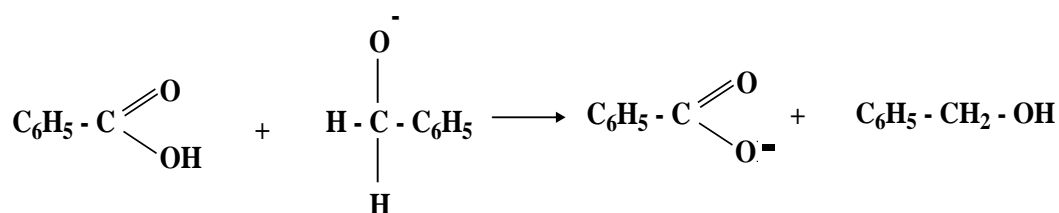

10.4. Laboratory Work

Aldehydes and Ketones

Test 1. Formaldehyde oxidation by heavy metals cations in alkali medium

(a) The Tollens' silver mirror test

Add 2–3 drops of 5 % silver nitrate (AgNO_3) solution into a test tube and treat it by one drop of 10 % sodium hydroxide (NaOH) solution. Dissolve the prepared dark-brown precipitate in the excess of aqueous ammonia and treat the prepared solution by 4 drops of 40 % formalin. What can you see? Write the equations of fulfilled reactions:

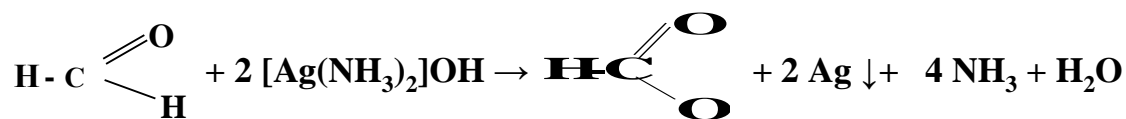
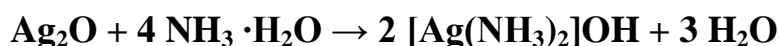
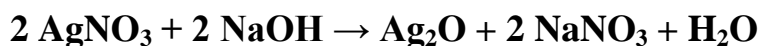

Formic acid is an aldehydoacid (its molecule contains both aldehydo- and carboxyl groups) hence it undergoes further oxidation into carbon dioxide and water:

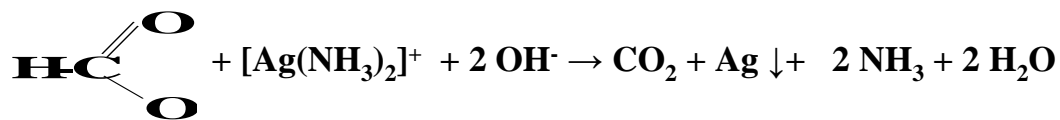

Repeat the experiment using acetone instead of formalin. Can you see any analytical effect? Why?

(b) Oxidation by Copper (II) Hydroxide

Pour 8–10 drops of 10 % sodium hydroxide solution and distilled water into a test tube and add 1–5 drops of 2 % copper (II) sulfate CuSO_4 solution. Treat the prepared precipitate by 3–6 drops of 40 % formalin. Heat a mixture up to the boiling point. What can you see? Write the equations of the performed reactions:

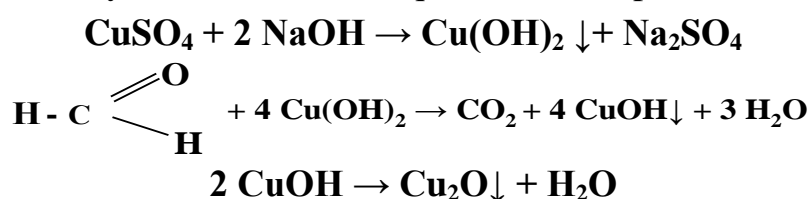

Repeat the experiment using acetone instead of formalin. Can you see any analytical effect? Why?

Test 2. Acetone oxime preparing

Put some crystals of hydroxylamine hydrochloride $\text{NH}_2\text{OH} \cdot \text{HCl}$ into a test tube and add some crystals of soda. Dissolve the prepared mixture in 10–25 drops of distilled water. After carbon dioxide gas liberation add 15–20 drops of acetone into a test tube and stir a prepared mixture. Pay attention that the reaction is highly exothermic. It results in white crystals of acetone oxime precipitation:

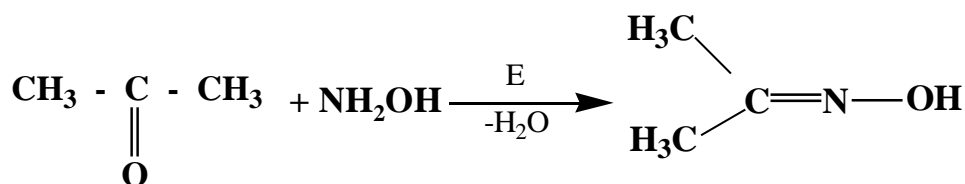

Test 3. Iodoform test

This clinical test is used for diagnosis of diabetes mellitus. Pour 5 drops of iodine solution into a test tube and treat it by the excess of 10 % sodium hydroxide solution. After a solution becomes colorless add 1–3 drops of acetone into it and warm a test tube in your hands. What can you see? Give the scheme of the reactions that were performed:

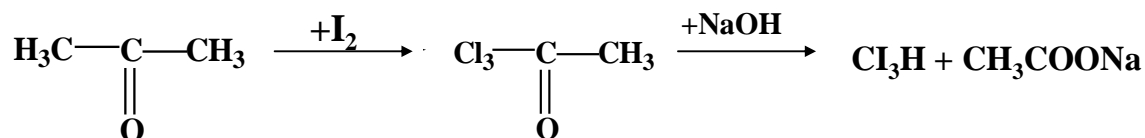

Test 4. Disproportionation of formaldehyde (Cannizzarro-Tischenko reaction)

Pour 2–3 drops of 40 % formalin into a test tube and treat it with 1 drop of 0.2 % methyl red solution. What can you see? Write the equations for the performed reaction:

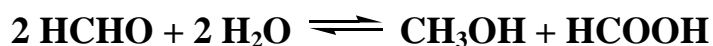

Test 5. Oxidation of ethyl alcohol

Pour 1 ml of potassium dichromate solution into a test tube and add the equal volume of dilute sulfuric acid. Treat the prepared solution by 1 ml of ethyl alcohol under heating. What can you see? Write the equations for the performed reaction.

10.5. Exercises for the Self-control

1. Write a structural formula for each of the following compound:

- 4-methylpentanal;
- penten-2-al;
- octanone-3;
- 1-phenylbutanone-2;
- benzylphenylketone;
- 2,2-dibromohexanal.

2. Write an equation for the synthesis of pentanone-2 by:

- oxidation of an alcohol;
- hydration of an alkyne.

3. Write the chemical equations for the reaction of p-bromobenzaldehyde with each of the following reagents:

- Tollens' reagent;
- HCN;
- Methylamine;
- excess methanol, dry HCl;
- Lithium aluminum hydride;
- phenylamine.

Name the organic products.

4. Acetaldehyde was treated with ethyl alcohol in acidic medium. Write an equation for a hemiacetal formation. Name it. Show all steps in the reaction's mechanism.

5. Write the equation for aldol condensation, which occurs when a solution of ethanal is treated with catalytic amounts of aqueous base. Show all steps in the reaction mechanism.

6. Write an equation for the reaction of ethanal with ethyl amine. Name the product.

7. Write an equation for benzaldehyde disproportionation in strong basic medium.

8. Write the equations for propanal reduction *in vitro* and *in vivo*.

CHAPTER 11 CARBOXYLIC ACIDS

After reading this chapter, you should be able to:

- define carboxylic acids and their functional derivatives;
- describe classification and nomenclature of carboxylic acids;
- discuss chemical properties of carboxylic acids and their functional derivatives;
- define all steps in nucleophilic substitution mechanism (S_N).

11.1. Classification of Carboxylic Acids

Carboxylic acids are the most important organic acids. Their functional group is the *carboxyl group*. This name is a contraction of the two parts: the carbonyl and hydroxyl groups. General formulas for carboxyl group and carboxylic acid are:

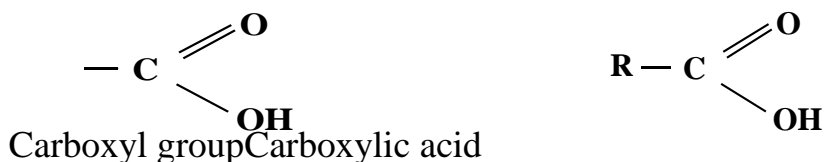

Because of their abundance in nature, carboxylic acids were among the earliest classes of compounds studied by organic chemists. Many acids have common names that indicate the original source of the acid.



Stinging ants are source of formic acid, HCOOH



The valerian root is a source of valeric acid $\text{CH}_3(\text{CH}_2)_3\text{COOH}$



Goats are a source of caproic, caprylic, and capric acids: $\text{CH}_3(\text{CH}_2)_n\text{COOH}$
 $n = 4, 6, 8$

The classification of carboxylic acids can be done by various features. By a number of carboxyl groups in a molecule they fall into three categories:

- monocarboxylic acids;
- dicarboxylic acids;
- tricarboxylic acids.

By a nature of radicals adjacent to carboxyl acids we can distinguish:

- saturated carboxylic acids;
- unsaturated carboxylic acids;
- aromatic carboxylic acids.

Let's review the main homologous series of carboxylic acids (Table 11.1).

Table 11.1. — Structural formulas and naming of some carboxylic acids

| Formulas | Systematic names | Common names |
|---|-------------------|-----------------|
| Saturated Monocarboxylic Acids | | |
| $\begin{array}{c} \text{O} \\ \parallel \\ \text{H} - \text{C} \\ \backslash \\ \text{OH} \end{array}$ | Methanoic acid | Formic acid |
| $\begin{array}{c} \text{O} \\ \parallel \\ \text{CH}_3 - \text{C} \\ \backslash \\ \text{OH} \end{array}$ | Ethanoic acid | Acetic acid |
| $\begin{array}{c} \text{O} \\ \parallel \\ \text{CH}_3 - \text{CH}_2 - \text{C} \\ \backslash \\ \text{OH} \end{array}$ | Propanoic acid | Propionoic acid |
| $\begin{array}{c} \text{O} \\ \parallel \\ \text{CH}_3 - \text{CH}_2 - \text{CH}_2 - \text{C} \\ \backslash \\ \text{OH} \end{array}$ | Butanoic acid | Butyric acid |
| $\begin{array}{c} \text{O} \\ \parallel \\ \text{CH}_3 - (\text{CH}_2)_3 - \text{C} \\ \backslash \\ \text{OH} \end{array}$ | Pentanoic acid | Valeric acid |
| $\begin{array}{c} \text{O} \\ \parallel \\ \text{CH}_3 - (\text{CH}_2)_4 - \text{C} \\ \backslash \\ \text{OH} \end{array}$ | Hexanoic acid | Caproic acid |
| Saturated Dicarboxylic Acids | | |
| HOOC - COOH | Ethanedioic acid | Oxalic acid |
| HOOC - CH₂ - COOH | Propanedioic acid | Malonic acid |

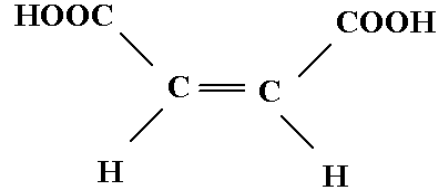
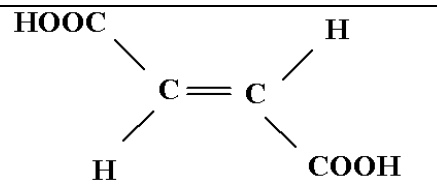
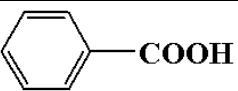
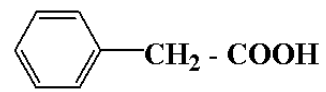
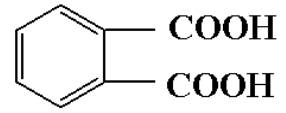
| Formulas | Systematic names | Common names |
|---|------------------------|--------------------|
| $\text{HOOC} - \text{CH}_2 - \text{CH}_2 - \text{COOH}$ | Butanedioic acid | Succinic acid |
| $\text{HOOC} - \text{CH}_2 - \text{CH}_2 - \text{CH}_2 - \text{COOH}$ | Pentanedioic acid | Glutaric acid |
| Unsaturated Monocarboxylic Acids | | |
| $\text{H}_2\text{C} = \text{CH} - \text{COOH}$ | Propenoic acid | Acrylic acid |
| $\text{H}_3\text{C} - \text{CH} = \text{CH} - \text{COOH}$ | Butene-2-oic acid | Crotonic acid |
| $\text{H}_3\text{C}(\text{CH}_2)_7\text{CH}=\text{CH}(\text{CH}_2)_7\text{COOH}$ | | Oleic acid |
| Unsaturated Dicarboxylic Acids | | |
|  | cis-Butenedioic acid | Maleic acid |
|  | trans-Butenedioic acid | Fumaric acid |
| Aromatic Acids | | |
|  | | Benzoic acid |
|  | | Phenyl-acetic acid |
|  | | Terephthalic acid |

Let's consider some common related classes of compounds called *acid derivatives*. In their molecules the –OH group of an acid is replaced by other functions –OR, halogens, or others). Their general formula is:

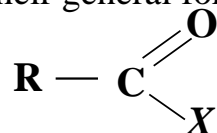

The formulas of acid derivatives are represented as follows:

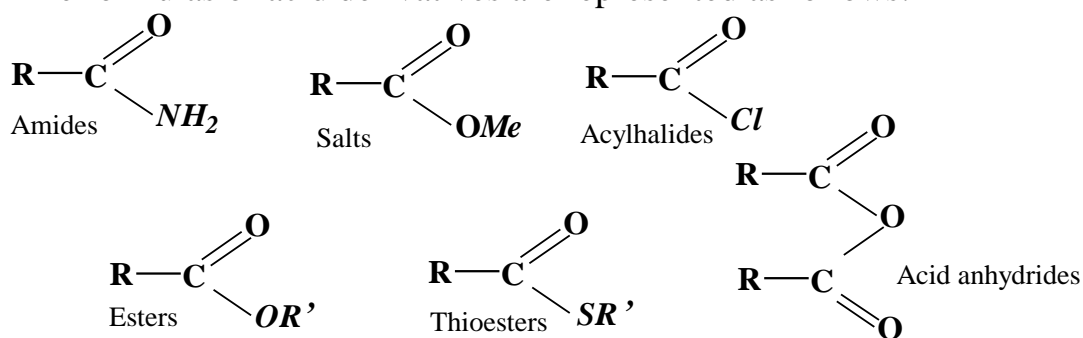

Esters and amides occur widely in nature. Anhydrides are uncommon in nature. Acyl halides are strictly creatures of the laboratory.

11.2. Chemical Properties of Carboxylic Acids — S_N

Carboxylic acids and acid derivatives are involved into nucleophilic substitution reactions. Like aldehydes and ketones they contain electrophilic, nucleophilic and weak CH acidic centers (Chapter 5.2). Unlike aldehydes and ketones, acids and their derivatives contain a substituent X adjacent to carbonyl carbon, which is a potentially leaving group. It may leave from a substrate as an anion X^- or an acid HX. Reactionary centers in carboxylic acids and acid derivatives are given in the following scheme:

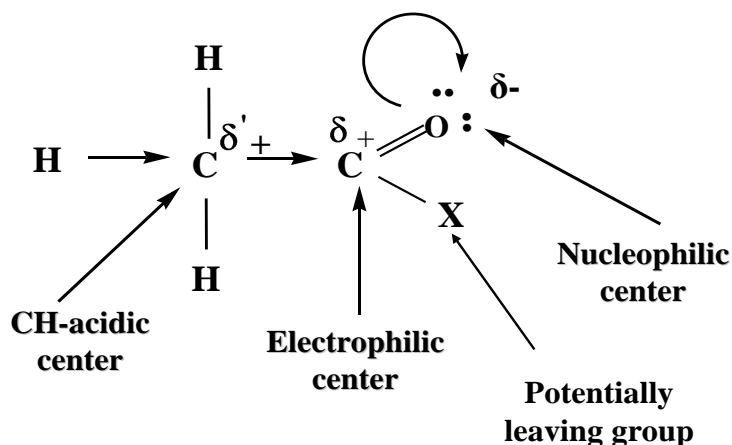

π -Bond in carboxylic acids is more stable than that in aldehydes and ketones since it is stabilized through resonance. This is a reason why acids undergo substitution but not addition.

Reactions of **nucleophilic substitution** involve the formation of an unstable anion (a product of nucleophile Y^- addition to carbonyl carbon) which is further stabilized by leaving of X^- group:

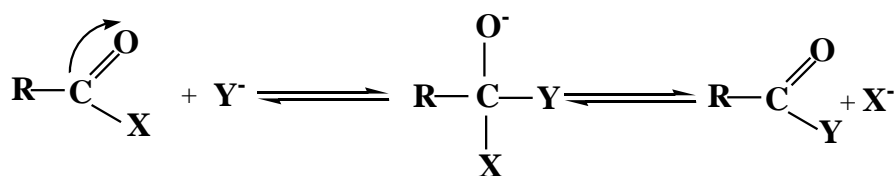

This mechanism is available when X^- is a good leaving group and Y^- is strong nucleophile. If not, H^+ ought to be used as a catalyst:

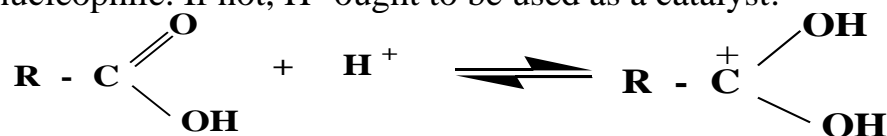

Proton addition increases positive charge on electrophilic center thus activating carboxylic acids to nucleophilic substitution reactions. The greater the positive charge on carbonyl carbon, the higher is reactivity of carboxylic acids and their derivatives. This electric charge is enhanced due to (-I)-effect of a substituent X and goes down due to its +R-effect. Reactivity of acids and acid derivatives is decreased in a following series:

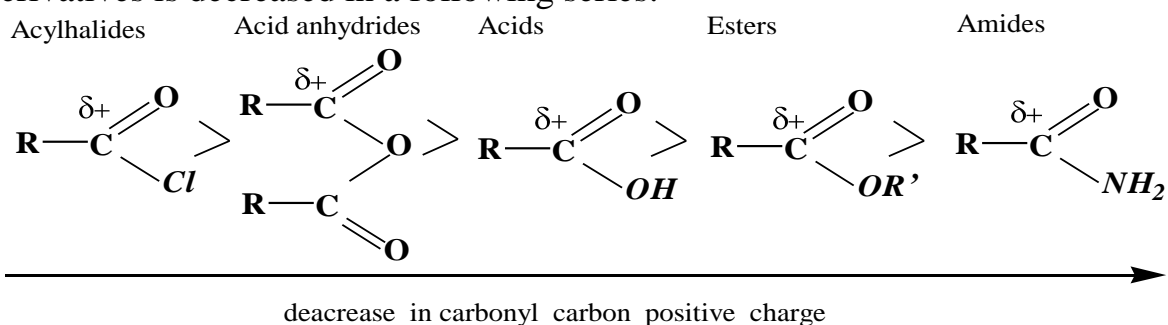

The typical reactions to produce acid derivatives are presented in Figure 11.1. All these processes run as nucleophilic substitution reactions.

The most important chemical property of carboxylic acids is their interaction with alcohols (esterification reactions). These reactions are reversible and their mechanism involves four steps.

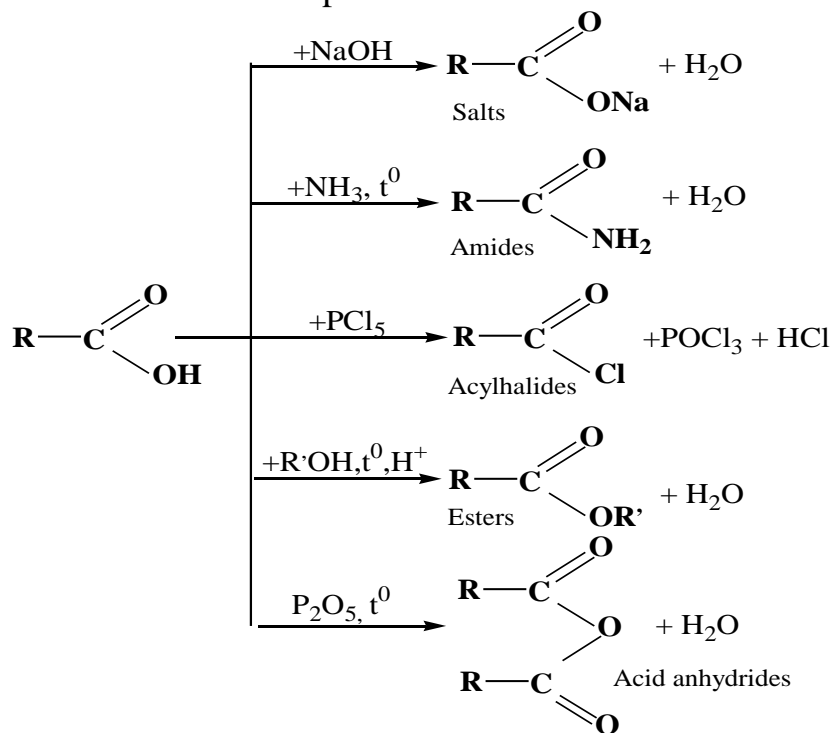
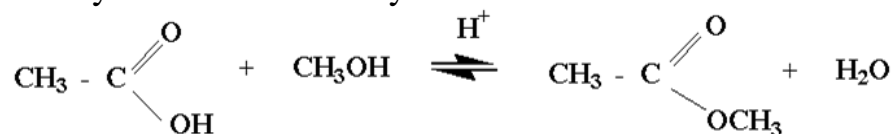
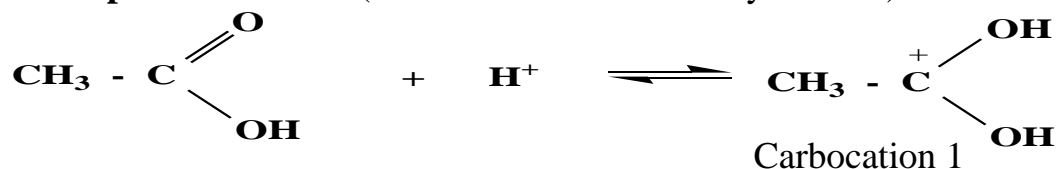

Figure 11.1. — The typical reactions to produce acid derivatives

For example, acetic acid is esterified by methanol with the formation of an ester named methylacetate or methylacetate:



Step 1. Protonation (H^+ addition to the carbonyl carbon):



Step 2. A nucleophilic attack of water to the electrophilic center of the protonated acid:

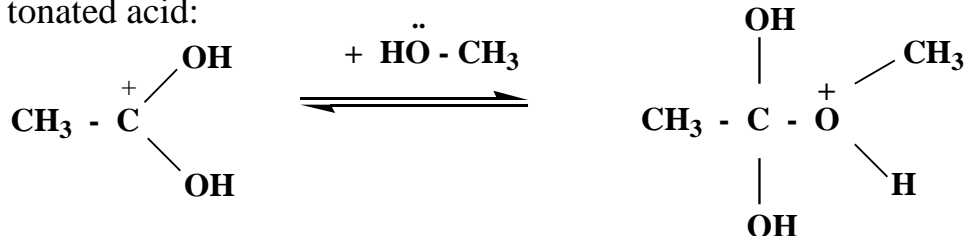

Oxonium cation

Step 3. Elimination of water; poor leaving OH-group leaves from a substrate as water molecule:

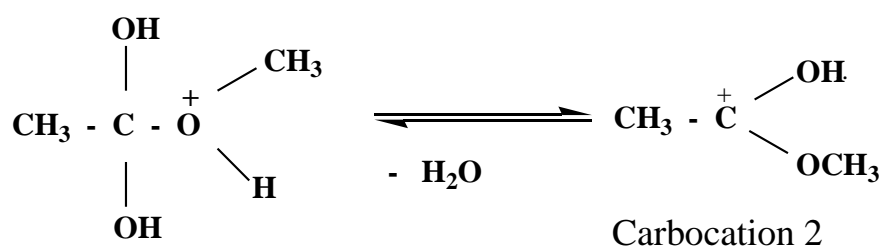

Step 4. Deprotonation and regeneration of an acid catalyst:

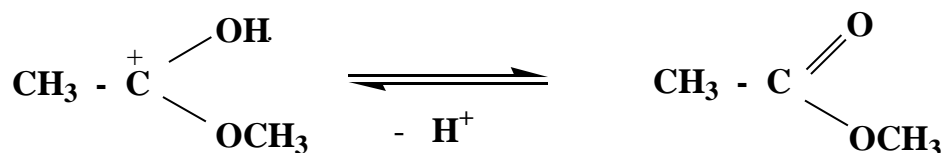

The carboxylic acids esterification by alcohols is a nonspontaneous process. Free energy change (ΔG) for these reactions are in the range +10 to +30 kJ/mol. The activation of a carboxylic acid toward esterification reaction can be performed by converting it into an acid anhydride or an acyl halide. These acid derivatives contain good leaving groups and can be readily converted into esters:

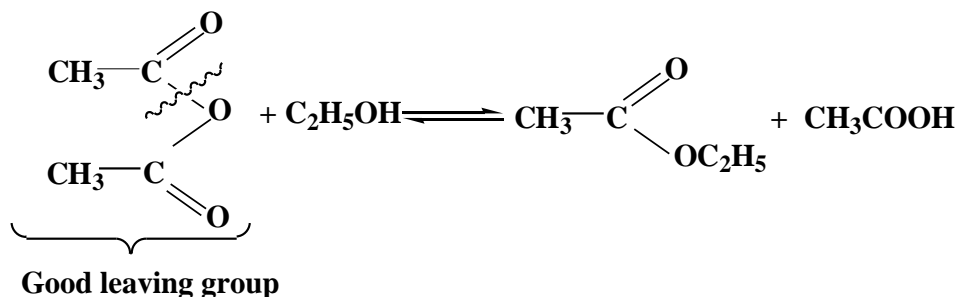

For example, the yield of ester in the reaction of acetic acid anhydride and ethanol is 60–80 %, while the yield of esters in esterification reactions is only 30–40 %.

Besides nucleophilic substitution reactions, carboxylic acids enter into **decarboxylation** and **dehydration** reactions.

Decarboxylation is energetically favorable process because of high stability of CO_2 molecule. Electron withdrawing substituents on α -position promote these reactions. Especially easy decarboxylation of dicarboxylic acids occurs since one of the carboxyl groups behaves as the electron withdrawing substituent. Decarboxylation reactions are running under heating. For example, oxalic acid turns into formic acid and malonic acid turns into acetic acid under heating:

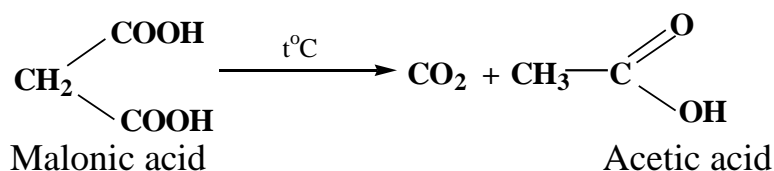
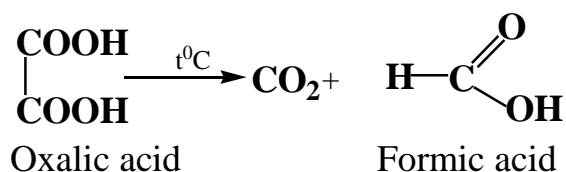

Decarboxylation of amino acids is the main pathway for biological amines synthesis *in vivo*:

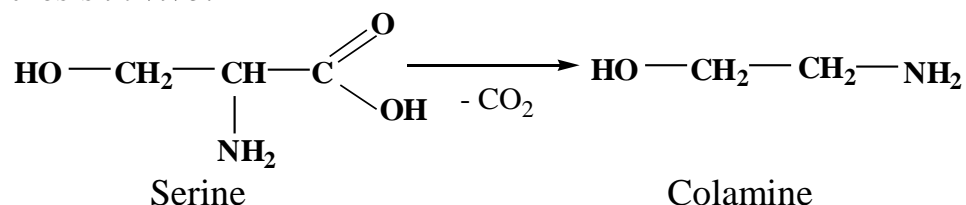

Decarboxylation of amino acids is catalyzed by the enzyme called decarboxylase.

Succinic and glucaric acids undergo not decarboxylation but dehydration and cyclization under heating. Such as reactionary pathway is preferable because it results in the formation of five- and six- membered rings. Such rings are practically free of strain and thus stable.

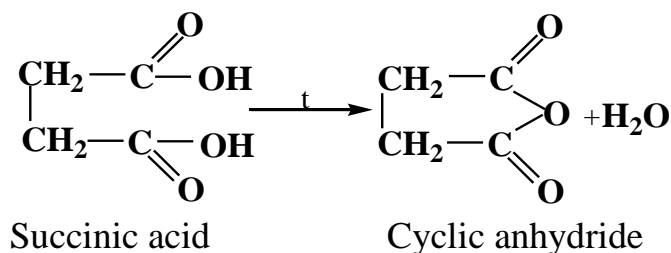

Saturated carboxylic acids with α -carbon are active in **halogenation reactions**.

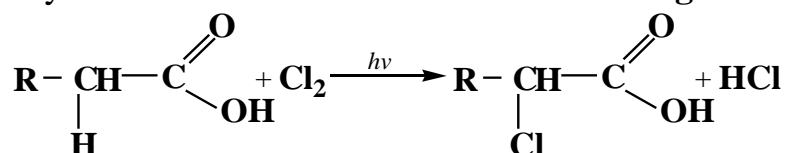

Halide derivatives are used in preparing α -amino- and α -hydroxyl carboxylic acids.

For unsaturated acids **addition of bromine** is the analytical test-reaction:

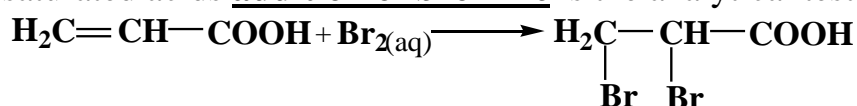

11.3. Esters and their Hydrolysis

Esters are the most important derivatives of carboxylic acids. Most of them are rather pleasant-smelling substances and are responsible for the flavor and fragrance of many fruits and flowers.

Lipids are esters of glycerol and fatty acids:

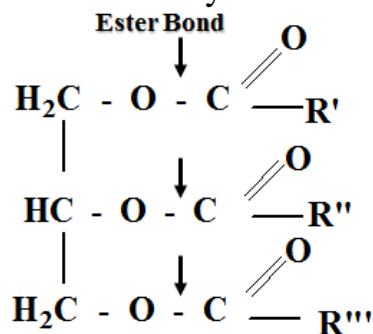

Some esters are applied as medicines. For example, aspirin, which is the ester of salicylic and acetic acids, is the most popular pain killer in the world (Figure 11.2).

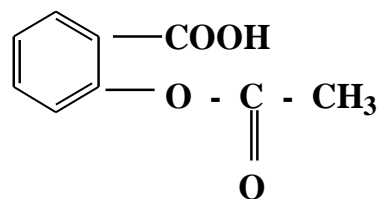

Figure 11.2 — Aspirin



Aspirin has been used to treat toothaches, headaches, arthritis and other pain maladies for more than 100 years. But only in 1969 Dr. John Vane from London University came to understand how it works. People feel pain when injured cells produce and release prostaglandins by oxidation of arachidonic acid. Aspirin inhibits the production of prostaglandins by injured tissue thus reducing pain and inflammation.

Sir John is credited with discovering how aspirin and similar drugs produce their effects; his work provided a scientific basis for the pain-relieving and anti-inflammatory effects of aspirin and also provided an explanation for how aspirin prevented blood clots and helped prevent heart attacks and strokes. As a result, aspirin is still one of the most common drugs used to treat people with heart disease.

Sir John Vane (1927-2004) shared the Nobel Prize in Medicine and Physiology in 1982 for his work on prostaglandins. He was especially acknowledged for the discovery of a protective factor, which he called prostacyclin, which helps to keep blood vessels healthy. Sir John also assisted with the development of a family of medicines called ACE inhibitors, which are widely used to treat high blood pressure, heart failure and a number of other vascular diseases.



Not only esters but thioesters are abundant in nature. They play an essential role in metabolic processes. The most important of them is **acetyl-coenzyme A** which is a thioester of acetic acid and coenzyme A.

Coenzyme A is a complex thiol. It is usually abbreviated by the symbol CoA-SH.

Coenzyme A is made up of three parts — adenosine diphosphate (ADP), pantothenic acid (a vitamin), and 2-aminoethanethiol — it is the thiol group that gives coenzyme A its most important functions:

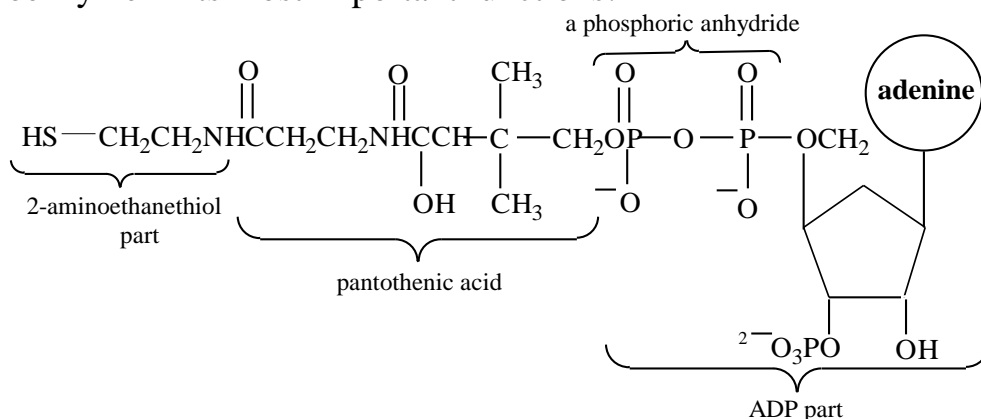

Acetyl-coenzyme A is synthesized in a body by coenzyme A reaction with acetic acid. It's formula is abbreviated as

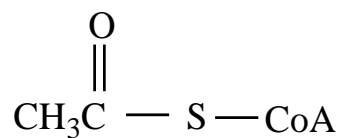

Acetyl-CoA reacts with many nucleophiles to transfer the acetyl group. It's an acylation process:

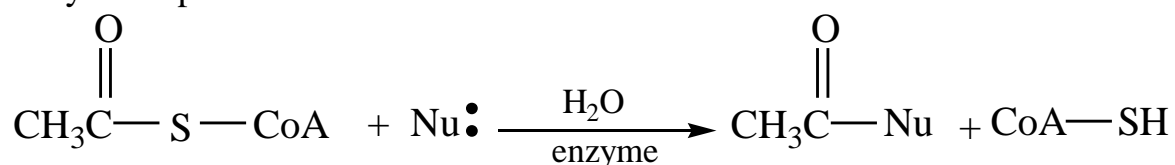

The reactions are usually enzyme-mediated and occur rapidly at ordinary cell temperatures. Why are thioesters superior to ordinary esters as acyl-transfer agents? Part of the answer lies in the acidity difference between alcohols and thiols (Chapter 5.2.). Since thiols are much stronger acids than are alcohols, their conjugate bases, $-\text{SR}$, are much weaker bases than $-\text{OR}$. Thus the $-\text{SR}$ group of thioesters is a much better leaving group, in nucleophilic substitutions, than is the $-\text{OR}$ group of ordinary esters. Thioesters are not so reactive that they hydrolyze in cellular fluid, but they are appreciably more reactive than simple esters. Nature makes use of this fact.

The most important chemical property of esters is their hydrolysis, which may be catalyzed by acids or bases. Hydrolysis is the nucleophilic substitution reaction. Acid-catalyzed hydrolysis is reversible and involves four steps.

Let's consider the acid-catalyzed hydrolysis of ethylacetate. The equation of a reaction is given below:

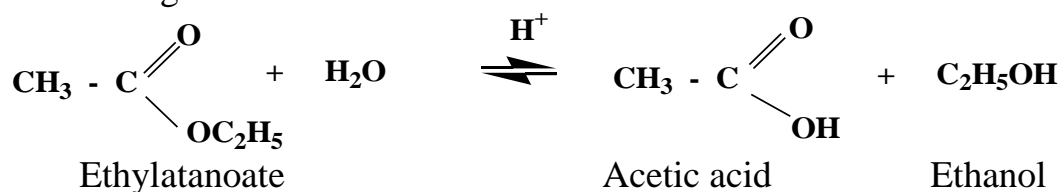

Step 1: Protonation:

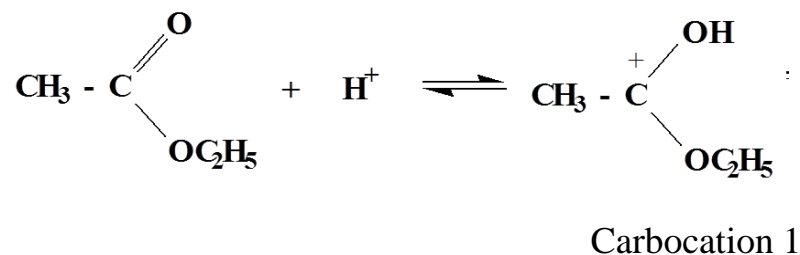

Step 2. A nucleophilic attack of water to the electrophilic center of the protonated ester:

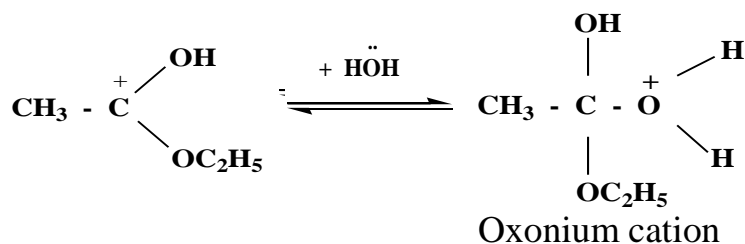

Step 3. Elimination of an alcohol; poor leaving OR-group leaves from a substrate as alcohol molecule:

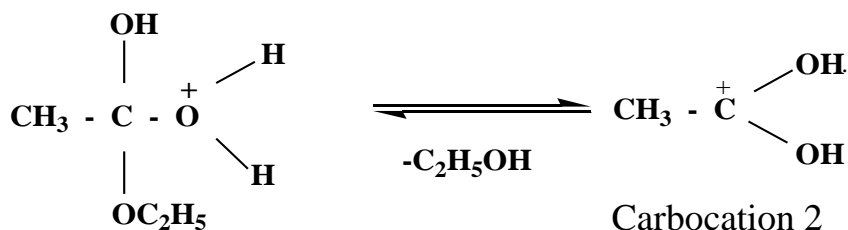

Step 4. Deprotonation or regeneration of an acid catalyst:

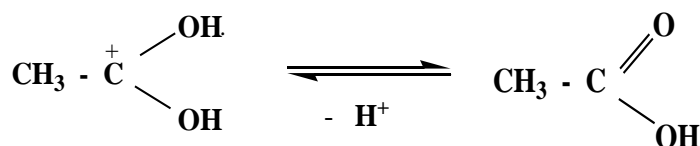

However, acyl halides and anhydrides are hydrolyzed quite rapidly by water and are therefore incompatible with cellular fluid. Most ordinary esters, on the other hand, react too slowly with nucleophiles for acyl transfer to be carried out efficiently at body temperatures.

Base-catalyzed hydrolysis of esters (saponification) is an irreversible process and requires the equivalent amount of alkalis:

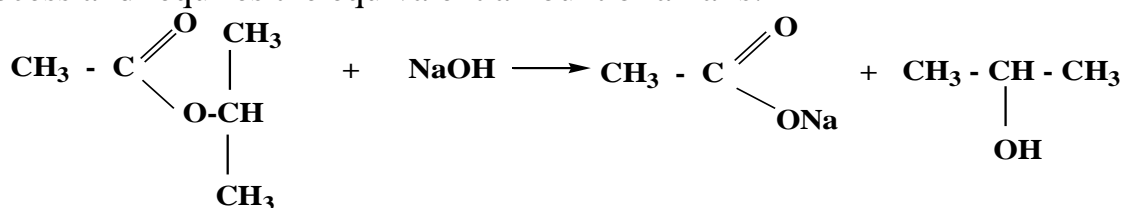

Isopropylatanoate

Sodium acetate

Isopropanol

The mechanism of base-catalyzed hydrolysis involves only 2 steps.

Step 1. Addition of hydroxide anion to the carbonyl carbon

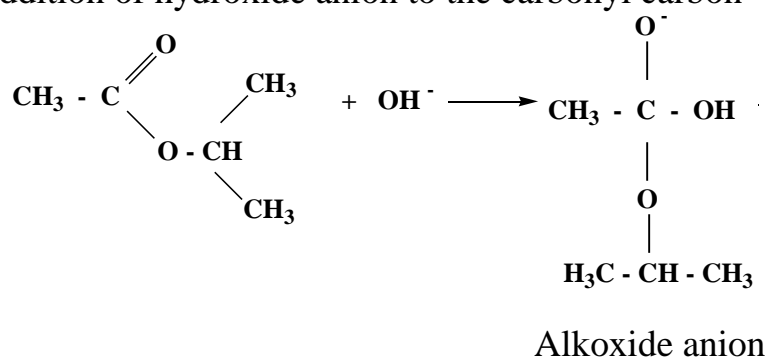

Step 2. Elimination of an alcohol

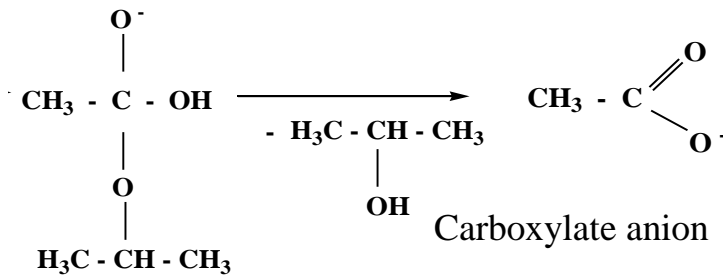

Creatine ethyl ester is a form of creatine that has an extra ester attached to it. The main function of creatine ethyl ester is to increase muscle size and strength in the body. It may also be referred to as CEE or creatine ester.

The amino acid is mostly used to increase muscle volume, and this is achieved by increasing the water uptake in muscle tissues. Creatine uses fat molecules as a method of transport to the various body cells, and it converts to creatine phosphate that may be used as energy. It may, therefore, be able to provide the body with an immediate supply of energy in short bursts. This is also why creatine is more suitable for activities such as weight training rather than endurance sports.

Creatine ethyl ester is usually used by bodybuilders and strength training athletes to improve their training performance and maximize their results. It is believed to be more effective than creatine monohydrate and may also be taken in smaller dosages to get the same desired effect. It is also said to have a much better absorption rate than normal creatine monohydrate.

Creatine is naturally produced in the body, and it can mostly be found in the brain, heart and muscles. It is produced in the liver from arginine, glycine, and methionine. Usually, the body can produce up to two grams of creatine per day, depending on what is needed. Physical training may also cause an increase in the production of creatine in the body.

It may also be found in various food sources such as meat and fish. It can also be taken separately as a supplement and usually comes in the form of a powder or a capsule. Many bodybuilding products such as meal replacements contain creatine to assist in muscle building.

The recommended dosage for creatine ethyl ester is about two grams per day, and this may be increased if needed. Many experts advise that creatine supplementation should be stopped after a few weeks of continued use to prevent the body from shutting down the natural production of it. A new cycle may be started again after one month.

Some of the side effects of creatine may include muscle cramps and dehydration. These symptoms, however, are not very common and may only occur when large dosages are taken on a regular basis (Figure 11.3).



Figure 11.3 — Athletes and body builders might take creatine supplements under the assumption that it creates muscle mass

The described mechanism is valid not only for the base-catalyzed hydrolysis of esters, but for hydrolysis of thioesters, acyl halides, acid anhydrides, and acid amides. The reaction is irreversible due to high stability of Equilibrium shifts toward carboxylate anion which exhibits high stability of carboxylate anions that are stable through resonance.

Below is a diagram that represents acid- and base-catalyzed aspirin hydrolysis:

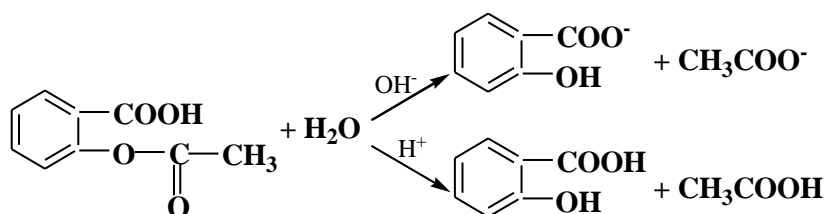

In vivo aspirin undergoes enzymatic hydrolysis.

11.4. Laboratory Work

CARBOXYLIC ACIDS

Test 1. Preparing of iron (III) acetate and its hydrolysis

Pour 3 drops of acetic acid and add 3 drops of distilled water into a test tube. After measuring the pH of a prepared solution, add 2–3 drops of 10 % NaOH solution to make a solution neutral. Treat a mixture with 2–3 drops of 1 % FeCl₃ solution and heat it up to the boiling point. What can you see? Write the equations of performed reactions:

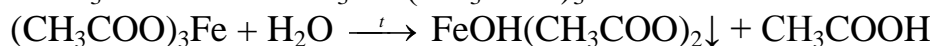
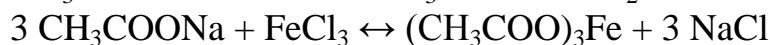
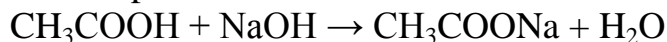

Test 2. Preparing of insoluble salts of fatty acids.

Pour soap's solution into the test tube and treat it with 10 % barium chloride solution. What can you see? Write the equation of a performed reaction:

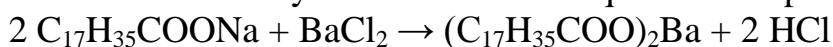
**Test 3. Soaps' hydrolysis**

Pour soap's solution into the test tube and treat it with some drops of distilled water. What can you see? Write the equation for soap's hydrolysis:

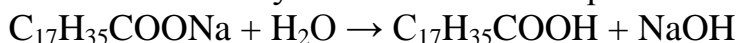
**Test 4. Chemical properties of oleic acid****(a) Oxidation of oleic acid by potassium permanganate solution**

Pour 2 drops of oleic acid into a test tube and treat it with 2 drops of 1 % potassium permanganate solution and 1 drop of 5 % sodium carbonate solution. Stir the prepared mixture. What can you see? Write the equation of a performed reaction.

(b) Bromine addition to oleic acid

Pour 0.5 ml of bromine water into a test tube and add 3–4 drops of oleic acid into it. Stir the mixture. What can you see? Write the equation of a performed reaction:

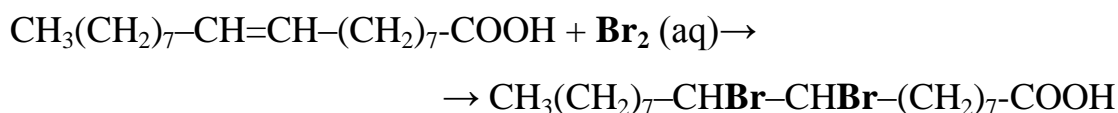
**Test 5. Ethyl acetate preparing**

Put some crystals of sodium acetate into a dry test tube and mix them with 0.5 ml of ethyl alcohol. Treat a prepared mixture with 2–5 drops of concentrated sulfuric acid and heat it in the fire of a spirit lamp. In few minutes a pleasant fresh fragrance of ethyl acetate must appear. This reaction is used as a test on ethyl alcohol.

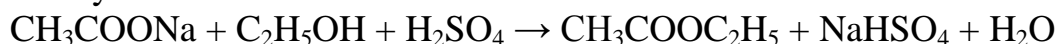
**11.5. Exercises for the Self-control**

1. Write a structural formula for each of the following acids.

- 4-methylpentanoic acid;
- 3-oxobutanoic acid;
- phenylacetic acid;
- cyclobutanecarboxylic acid;
- 2,2-dimethylbutanedioic acid;
- 2-aminopropanoic acid.

2. Write a structural formula for each of the following compounds.

- | | |
|------------------------------|-------------------------|
| a) sodium 2-chlorobutanoate; | b) calcium acetate; |
| c) phenyl benzoate; | d) <i>o</i> -toluamide; |
| e) propanoic anhydride; | f) ethyl formate. |

3. In each of the following pairs of acids, which would be expected to be the stronger, and why?

- ClCH_2COOH and BrCH_2COOH ;
- $\text{C}_6\text{H}_5\text{COOH}$ and $p\text{-CH}_3\text{C}_6\text{H}_4\text{COOH}$;
- CCl_3COOH and CF_3COOH .

4. Write an equation for:

- hydrolysis of propylacetate;
- esterification of 1-pentanol with acetic anhydride;
- ammonolysis of butanoic acid;
- reaction of benzoyl chloroanhydride with methanol;
- succinic acid + heat ($235\text{ }^\circ\text{C}$).

5. Write out each step in the mechanism for:

- esterification of benzoic acid with methanol;
- esterification of propanoic acid with isopropanol;
- acid-catalyzed hydrolysis of ethylacetate;
- saponification of $\text{CH}_3\text{CH}_2\text{COOCH}_3$.

6. Write the equations for the following scheme. Describe the mechanism for the second reaction. Give systematic names for the products.

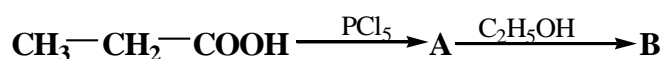

7. Esters can be made directly from Nitriles by acid-catalyzed reaction with appropriate alcohol. Suggest a mechanism.

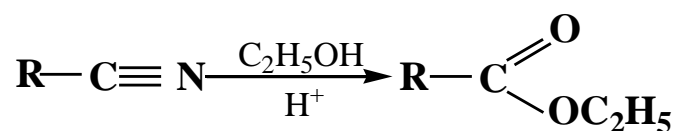

8. In making esters of the naturally occurring amino acids (general formula below) it is important to keep them as their hydrochloric salts. What would happen to these compounds if they were neutralized?

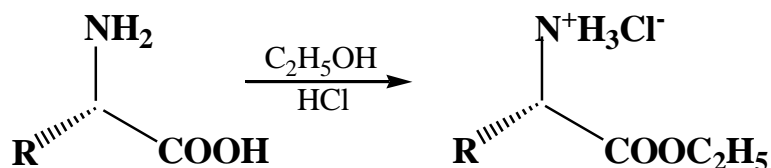

CHAPTER 12

SPECIFIC PROPERTIES OF ALIPHATIC POLY- AND HETEROFUNCTIONAL COMPOUNDS

After reading this chapter, you should be able to:

- define poly- and heterofunctional compounds and give their examples;
- define chiral molecules and describe their specific properties;
- be able to write the Fisher's projections of enantiomers and diastereomers;
- discuss specific properties of hydroxo-, amino and oxo acids respectively to α , β and γ location of their functional groups;
- discuss the pathways of serine and phenylalanine metabolism.

12.1. General Concepts

The vast majority of substances involved in the metabolism belong to polyfunctional or heterofunctional compounds. Below are the functional groups common in the compounds involved in the processes of life.

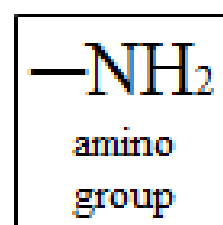
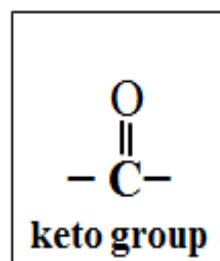
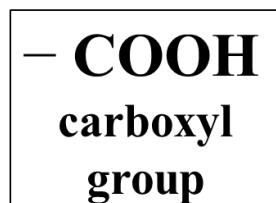
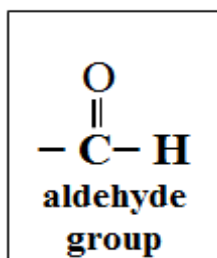
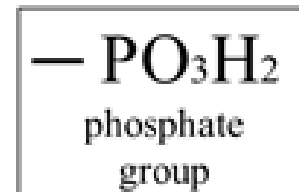
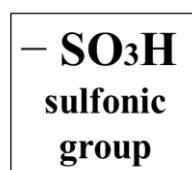
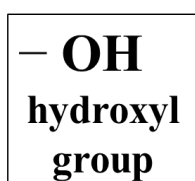

Polyfunctional are organic compounds that contain several identical functional groups in their molecules. The most common are compounds with hydroxyl groups — polyhydric alcohols and phenols. Most often found are dihydric alcohol ethylene glycol, trihydric alcohol glycerol, and dihydric phenols — catechol, resorcinol and hydroquinone.

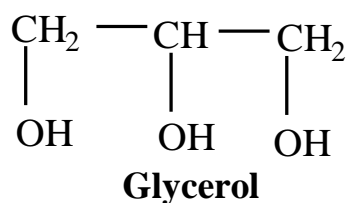
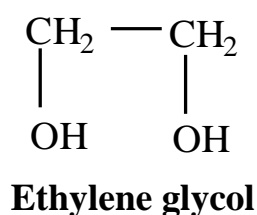

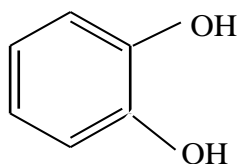

Catechol

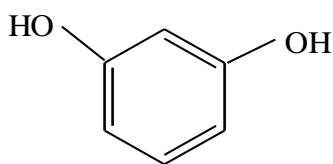

Resorcinol

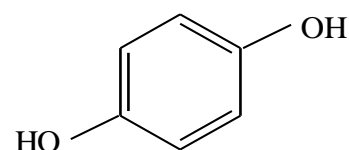

Quinol (Hydroquinone)



Glycerol is widely used in the food industry for two main reasons: it has a sweet taste, but has fewer calories than sugar; and it is hygroscopic, that is, it absorbs moisture from the air. It is therefore used both to sweeten foods and to keep them moist. The compound is metabolized more slowly than sucrose — the type of sugar most commonly found in candy and in processed foods — and therefore does not have such a dramatic effect on blood sugar levels. It also does not contribute to bacterial tooth decay. Foods marketed as being low in carbohydrates are often sweetened with glycerin.

Another major use is in the cosmetics industry. Due to its hygroscopic properties, it is used in many moisturizing skin products, as it seems to help relieve dry skin problems by drawing water up from the lower layers. It is also a component of glycerol soap, which is often used by people with sensitive skin. Lotions containing this compound are also popular.

Vegetable glycerol can be used as a substitute for ethanol — the chemical commonly called “alcohol” — in making botanical extracts, such as herbal essences. It acts as a solvent that dissolves the substances of interest from the raw plant material. The advantage of this is that people who do not want to be exposed to alcohol can still have access to the botanical products. The disadvantage is that the resulting products have a much shorter shelf life.

There are also medical uses for vegetable glycerol. It is a common ingredient in cough mixtures, due to its soothing properties. Other applications are as a topical remedy for a number of skin problems, including psoriasis, rashes, burns, bedsores and cuts; as a laxative, in the form of suppositories; and to treat gum disease, as it inactivates the associated bacterial colonies (Figure 12.1).



Figure 12.1— Suppositories made with glycerol

Heterofunctional compounds contain at least two different functional groups. The combinations of the most common functional groups that present in molecules of biologically important aliphatic compounds are given in Table 12.1.

Among the compounds with two different functional groups most naturally occurred are amino alcohols, hydroxy-, amino- and oxo acids.

Table 12.1 — The combinations of the most common functional groups that present in molecules of biologically important aliphatic compounds

| Functional groups | A type of a compound | Typical representatives |
|--|----------------------|---|
| -OH -NH ₂ | Amino alcohols | HOCH ₂ CH ₂ NH ₂ 2-aminoethanol |
| -OH -COOH | Hydroxy acids | CH ₃ CH(OH)COOH Lactic acid |
| -NH ₂ -COOH | Amino acids | NH ₂ CH ₂ COOH Glycine |
| $\begin{array}{l} \diagup \\ \text{C}=\text{O} \\ \diagdown \end{array}$ -COOH | Oxo acids | CH ₃ -CO-COOH Pyruvic acid |

Let's consider some biologically active heterofunctional compounds.

The amino alcohol 2-aminoethanol or colamine is a component of cell membranes

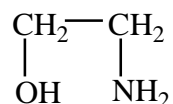

The amino acid α -alanine is a component of peptides and proteins

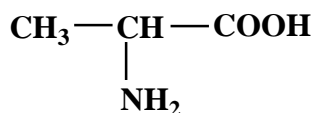

Among **hydroxy acids** that contain -OH and -COOH groups α -, β - and γ - acids are distinguished. For example, 2-hydroxy propanoic acid or **lactic acid** belongs to α -hydroxy acids:

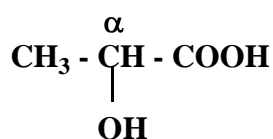

3-Hydroxybutanoic acid or β -hydroxy butyric acid is the example of β -hydroxy acids:

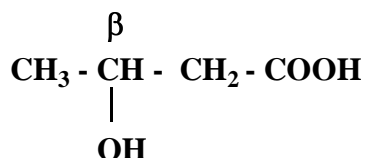

4-Hydroxy butanoic acid or γ -hydroxy butyric acid belongs to γ -hydroxy acids:

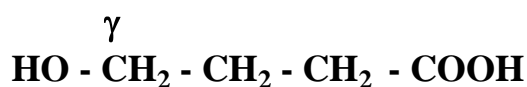

Among naturally occurred *di*- and **tricarboxylic acids with one hydroxyl group** are malic and citric acids:

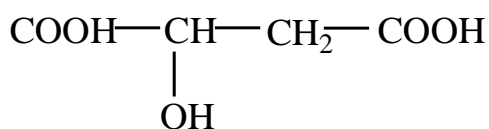

Malic acid

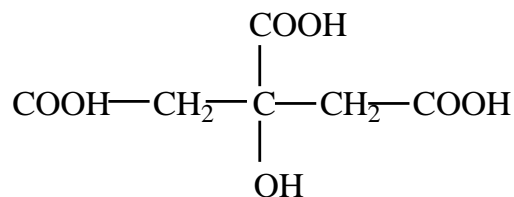

Citric acid

Malic acid is an organic compound made by all living organisms. It contributes to the pleasantly sour taste of fruits, and is used as a food additive. The salts and esters of malic acid are known as malates. The malate anion is an intermediate in the citric acid cycle.

Citric acid is a weak organic acid which is a natural preservative/conservative that occurs naturally in citrus fruits and is also used to add an acidic or sour taste to foods and drinks. In biochemistry, the conjugate base of citric acid, citrate, is important as an intermediate in the citric acid cycle, which occurs in the metabolism of all aerobic organisms. Citric acid is a commodity chemical, and more than a million tones are produced every year by fermentation. It is used mainly as an acidifier, as a flavoring, and as a chelating agent.

Oxo acids are subdivided into aldehydo- and keto- acids. Glyoxalic acid is an example of aldehyde carboxylic acids

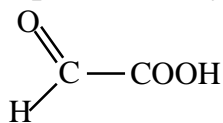

Glyoxalic acid

It is a colorless solid that occurs naturally and is useful industrially. Glyoxylic acid is about 10x stronger acid than acetic acid, with an acid dissociation constant of 4.7×10^{-4} (pKa = 3.32).

Pyruvic, acetoacetic, oxaloacetic, and α -ketoglutaric acids are naturally occurred *keto carboxylic acids*:

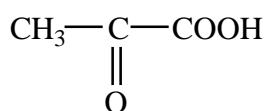

Pyruvic acid

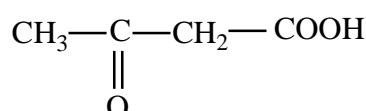

Acetoacetic acid

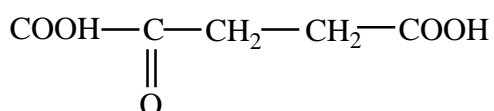

α -Ketoglutaric acid

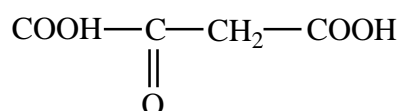

Oxaloacetic acid

β -Hydroxy butyric acid, acetoacetic acid and acetone are called *ketones bodies*:

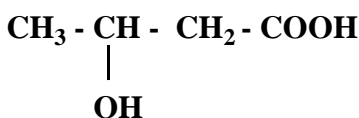

β -Hydroxy Butyric Acid

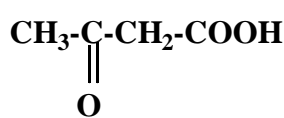

Acetoacetic Acid

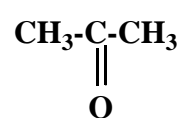

Acetone



Ketone bodies are produced by the liver from fatty acids during periods of low food intake (fasting) or carbohydrate restriction for cells of the body to use as energy instead of glucose. Two of the three are used as a source of energy in the heart and brain while the third (acetone) is a degradation breakdown product of acetoacetic acid. In normal individuals, there is a constant production of ketone bodies by the liver and their utilization by extrahepatic tissues. When the rate of synthesis of ketone bodies exceeds the rate of utilization, their concentration in blood increases; this is known as ketosis— excretion of ketone bodies in urine. Smell of acetone in breath is a common feature in ketosis.

When a type 1 diabetic suffers a biological stress event (sepsis, heart attack, infection) or fails to administer enough insulin he may suffer the pathological condition ketoacidosis. Liver cells increase metabolism of fatty acids into ketones in an attempt to supply energy to peripheral cells which are unable to transport glucose in the absence of insulin. The resulting very high levels of blood glucose and ketone bodies lower the pH of the blood and trigger the kidneys to attempt to excrete the glucose and ketones. Osmotic diuresis of glucose will cause further removal of water and electrolytes from the blood resulting in potentially fatal dehydration, tachycardia and hypotension.

12.2. Optical Isomerism

Molecules are three dimension objects and as all objects they may be symmetric or asymmetric. Symmetric molecules contain a plane of symmetry, which bisects them into two equal halves. Such molecules are named *achiral*. Symmetric (achiral) molecules can be superimposed upon their mirror images (Figure 12.2).

Propanoic acid is another example of achiral molecule:

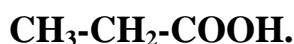

Molecules that lack a plane of symmetry are chiral (asymmetric). They and their mirror images cannot be superimposed on each other. The term “chiral” comes from Latin word “chiro” that means “hand” (Figures 12.3).

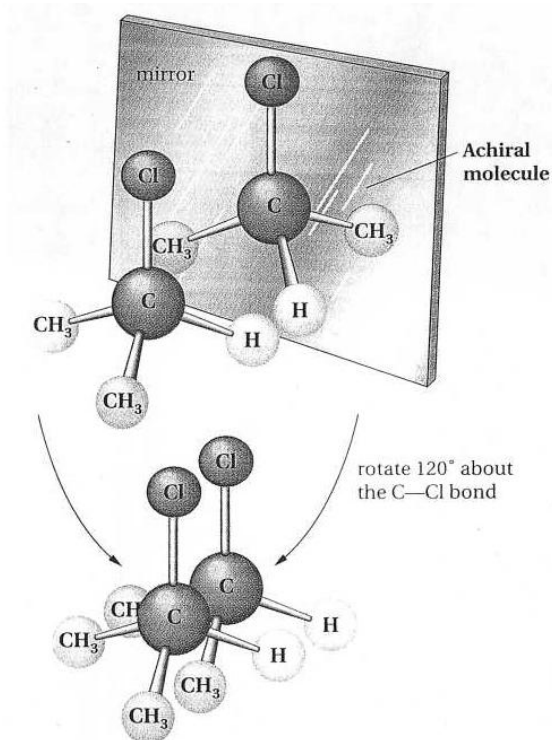

Figure 12.2 — Model of 2-chloropropane and its mirror image. The mirror image is super imposable on the original molecule

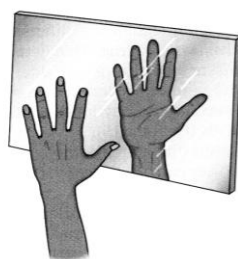
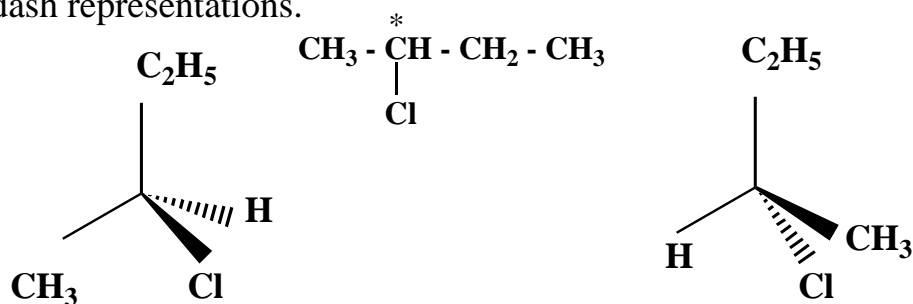

Figure 12.3 — The mirror image of a left hand is not a left hand, but a right hand

All chiral molecules contain one or several stereogenic centers. **Stereogenic center** is sp^3 -hybridized carbon atom with four different substituents attached to it.

Let's consider a chiral molecule of 2-chlorobutane. Its molecule contains one stereogenic center and forms two stereo isomers. Here you can see their wedge-and-dash representations.



Chiral compounds exhibit some specific properties. First of all they are optically active (Figure 12.4). It means that they rotate a plane of polarized light in some number of degrees:

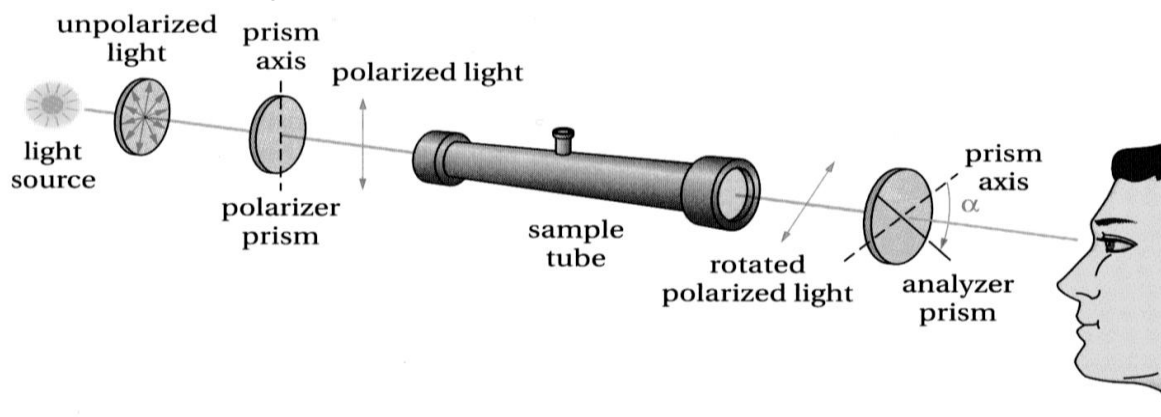

Figure 12.4 — Diagram of a polarimeter

Secondly they form configurational (optical) stereoisomers, which differ in a configuration of a stereogenic center. A number of optical isomers is equal to 2^n , where n is a number of stereogenic centers in a molecule of a chiral compound. Optical isomers fall into two categories: enantiomers and diastereomers.

Enantiomers are optical isomers that relate as nonsuperimposable mirror images. They exhibit identical physical and chemical properties, but differ in two significant ways:

a) both enantiomers of a pair rotate a plane of polarized light by the same number of degrees but in opposite direction (one clockwise and another counter clockwise);

b) each enantiomer of a pair reacts chemically in an individual way in an asymmetric environment to form another asymmetric compound. For example, they interact differently with enzymes or biological receptors (Figure 12.5). Equimolar mixture of enantiomers is named a **racemic mixture**; it is optically inactive.

As a rule only one enantiomer from a pair is involved into metabolism.

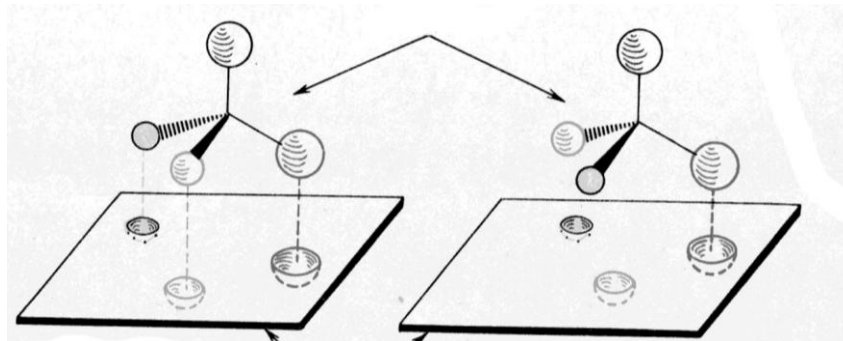
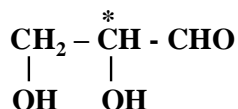

Figure 12.5 — The schematic representations for an interaction between a chiral substrate and an enzyme. The circles marked on the plane portray the active sites of enzymes

Diastereomers are stereoisomers that are not mirror images of one another. They exhibit different physical and chemical properties.

Structure of stereoisomers is usually represented as *Fischer projections*. In these formulas the stereogenic center is omitted and is represented as a crossing point of the horizontal and vertical lines. For example, glyceraldehyde contains one stereogenic center and forms a pair of enantiomers (Figure 12.6).

Glyceraldehyde is applied as a configurational standard. The types of all other stereoisomers are determined in comparison with its stereogenic centers. Letter D means that an isomer belongs to D-stereo chemical series; letter L- it's a member of L-stereo chemical series. Mainly L-amino- and hydroxy acids are biologically active.



Fischer Projections for Glyceraldehyde

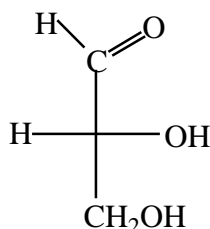

D-Glyceraldehyde

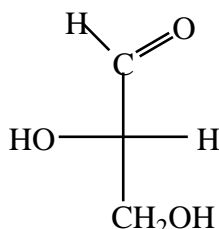

L-Glyceraldehyde

Figure 12.6 — Glyceraldehyde and their enantiomers

Let us consider lactic acid that is a product of glucose metabolic pathway.

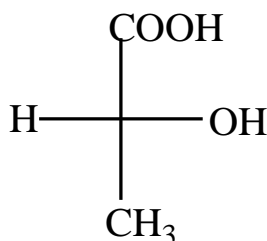
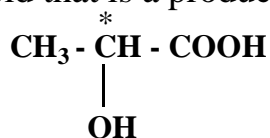

D-Lactic Acid

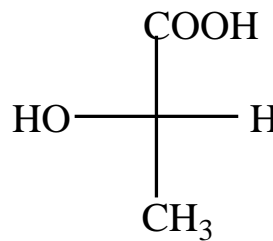

L-Lactic acid

Consider the optical isomers of malic acid that is involved into tricarboxylic acid cycle:

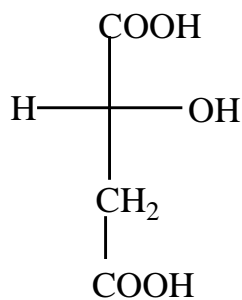
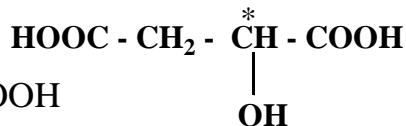

D-Malic Acid

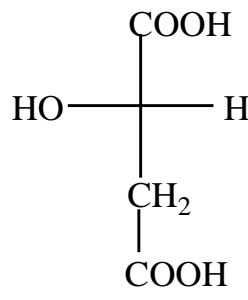

L-Malic Acid

Thus malic acid has two stereoisomeric forms, though only the L-isomer exists naturally.

Some hydroxy- and amino acids contain two stereogenic centers. For example, threonine (Thr) is α -amino acid involved in protein biosynthesis:

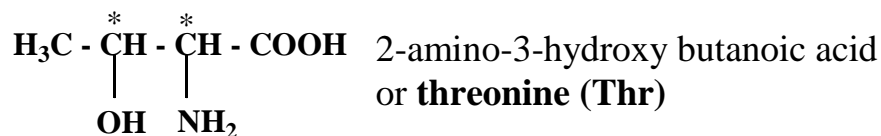

Threonine forms two pairs of enantiomers:

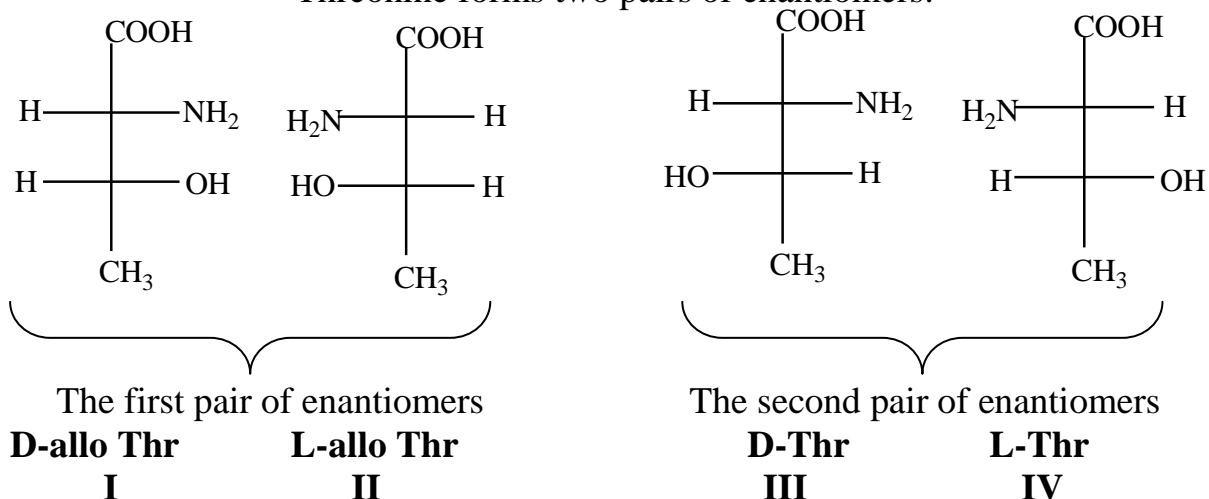

Enantiomers — I и II; III и IV. Diastereomers — I и III; I и IV; II и III; II и IV. Prefix *allo* is used to name stereoisomers, which are not involved in proteins' biosynthesis.

Let us consider stereoisomerism of tartaric acid (2, 3 -dihydroxy butanedioic acid):

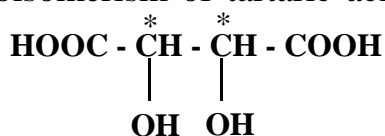

Its molecule contains two stereogenic centers and theoretically ought to form two pairs of enantiomers. But in fact there are only three stereoisomers: D-tartaric acid, L-tartaric acid and meso-tartaric acid.

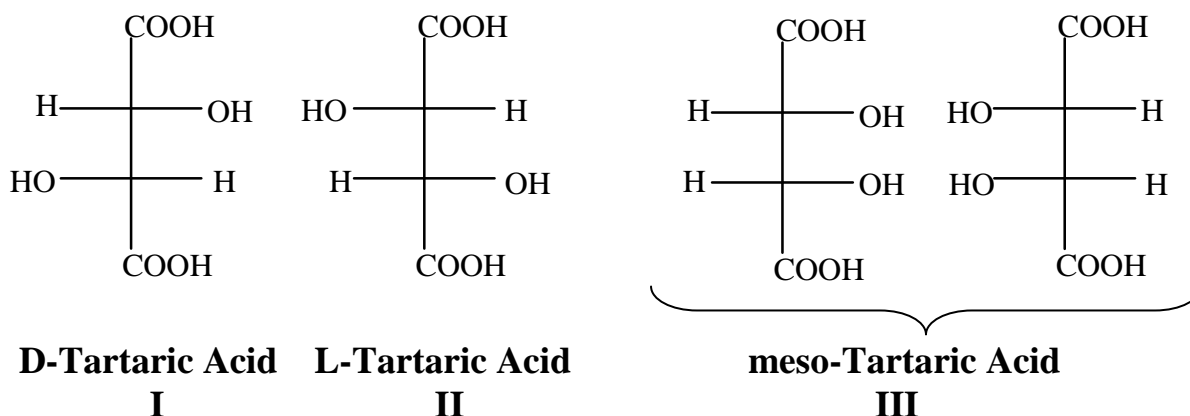

Meso-tartaric acid is achiral because it contains a plane of symmetry, which bisects a molecule into two halves that are mirror images of each other. It is not optically active.

π -Diastereomers (cis-trans isomers) are achiral molecules with double bonds as stereogenic centers. They differ from one another only in the way the atoms are positioned in space.

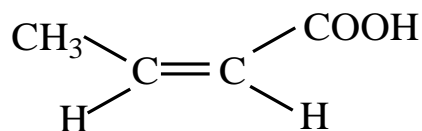

Isocrotonic acid

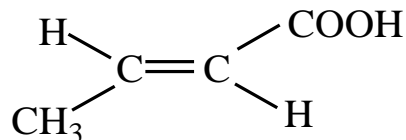

Crotonic acid

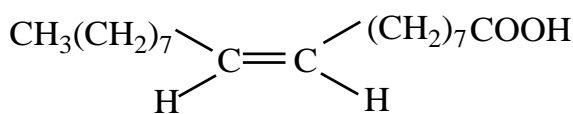

Oleic acid

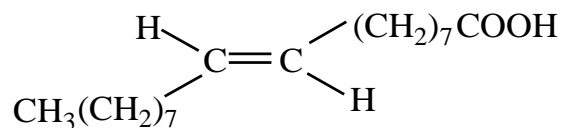

Elaidic acid

About 40 % of medicines are chiral; they are composed of several stereoisomers but only one isomer is therapeutically effective. Other isomers are ineffective and even dangerous for the health. In 1956 sedative thalidomide was introduced to the European market place. Immediately it became popular with pregnant women to control morning sickness. About the same time a number of congenitally deformed babies increased. The most seriously deformed babies were born with seal limbs (Figure 12.7).



Figure 12.7 — A baby with seal limbs

Thalidomide had been carefully tested. It was proved that it is a molecule that exists as two optical isomers (Figure 12.8). It was determined that one of its enantiomers was medically effective, but another was a teratogen and gave such a striking negative side effects. In 1998 the Food and Drug Administration (FDA) approved thalidomide for use in treating leprosy symptoms. Studies are also being conducted to determine the effectiveness of thalidomide in treating symptoms associated with AIDS, Behcet disease, lupus, Sjogren syndrome, rheumatoid arthritis, inflammatory bowel disease, macular degeneration, and some cancers.

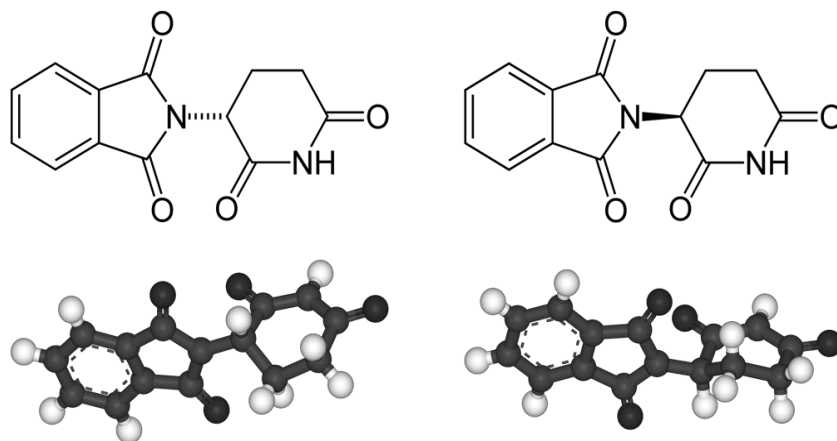
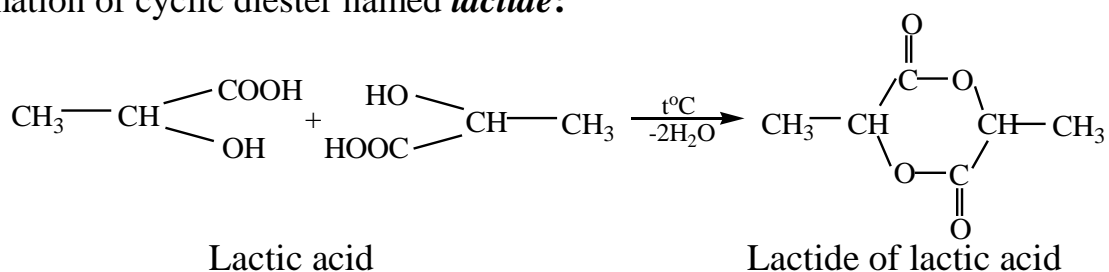

Figure 12.8 — Optical isomers of thalidomide

12.3. Specific Properties of Heterofunctional Compounds

Specific chemical properties of heterofunctional compounds are the result of different functional groups mutual affection. The groups effect each other by minus inductive effect ($-I$ -effect) thus they all are electron withdrawing groups. Inductive effect falls rapidly with distance therefore only α , β and γ -location of substituents is responsible for specific properties of heterofunctional compounds.

α -Location of substituents is responsible for intermolecular cyclization in α -amino- and α -hydroxy acids. For example, heating of lactic acid results in formation of cyclic diester named **lactide**:



Heating of α -amino propanoic acid (for example, α -alanine) results in formation of cyclic diamide named **diketopiperazine**:

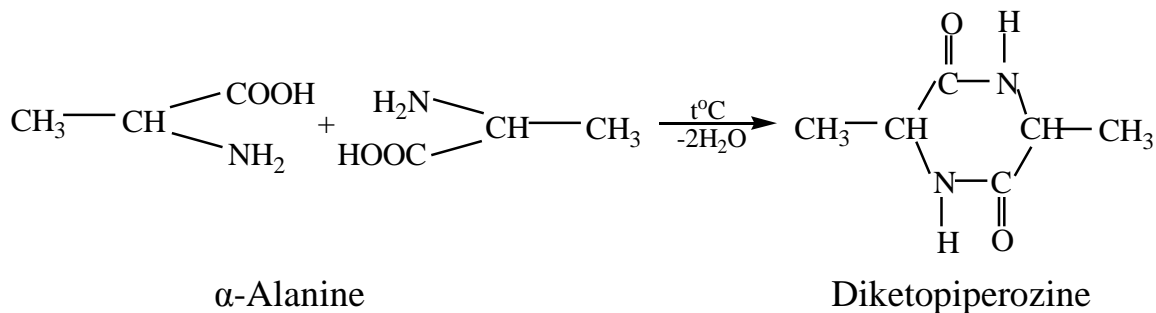

The formation of lactides and diketopiperazines is energetically favored due to high stability of six membered cycles.

Under heating in a strong acid medium α -hydroxy acids undergo decomposition into formic acid and an aldehyde:

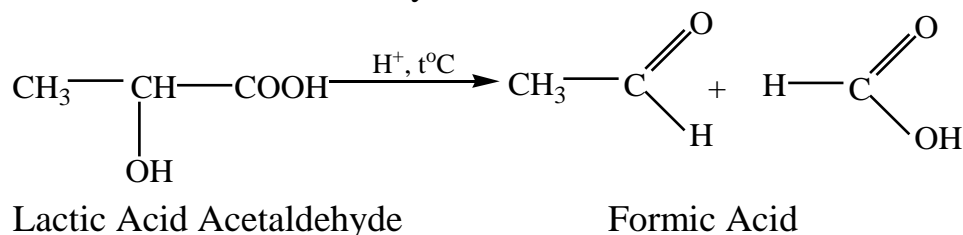

β -Location of functional groups in hydroxy acids is responsible for high acidity of CH-center which is situated between carboxyl and hydroxyl groups. These functional groups are electron-withdrawing substituents hence they enhance acidity of CH-acidity center:

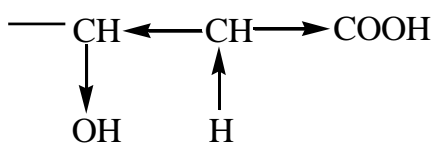

As the result β -location is responsible for H_2O and NH_3 elimination in amino- and hydroxy acids. The process runs under heating:

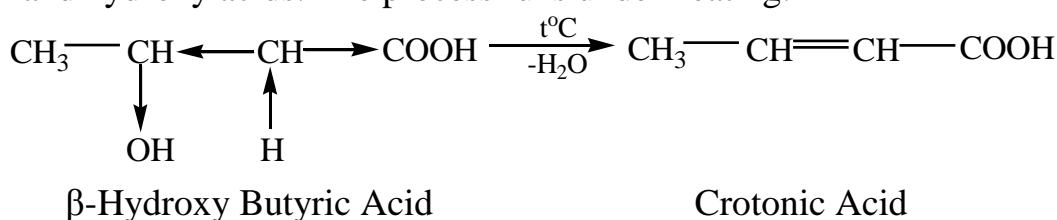

β -Location of functional groups is responsible for keto-enol tautomerism in oxo acids. They may exist as an equilibrium mixture of two forms, called **the keto form** and **the enol form**. The two forms differ in location of a proton and a double bond:

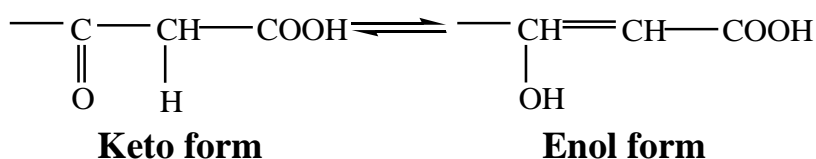

This type of structural isomerism is called **tautomerism** (from Greek *tauto*, the same and *meros*, part). The two forms of oxo acids are called **tautomers**.

Most carbonyl compounds exist mainly in the keto form. Acetone, for example, is 99.9997% on the keto form, with only 0.0003% of the enol present. The main reason for the greater stability of the keto form is that the $\text{C}=\text{O}$ plus $\text{C}-\text{H}$ bond energy present in the keto form is greater than the $\text{C}=\text{C}$ plus $\text{O}-\text{H}$ bond energy of the enol form. However there are some carbonyl compounds that exhibit the greater portion of enol form. For example, the acetoacetic ester (ethyl ester of acetoacetic acid) is a mixture that contains 92.5% of keto form and 7.5% of enol form at equilibrium:

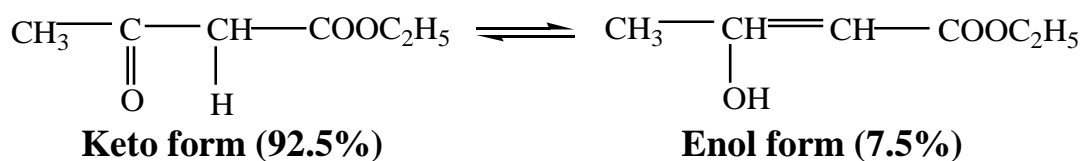

The enol form in acetoacetic ester is stabilized by π,π -conjugation of carbon, carbon double bond with carbonyl group. The acetoacetic ester gives reaction typical both for carbonyl compound and unsaturated hydrocarbons.

α - and β -Location of Substituents promotes **decarboxylation** of carboxylic acids:

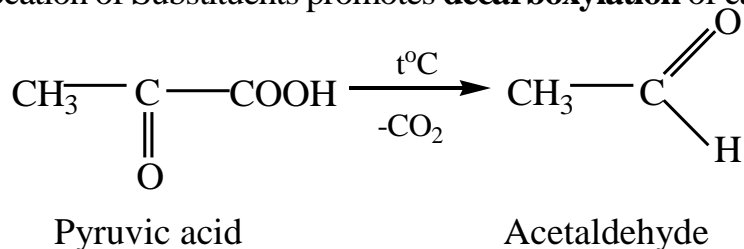

γ - **Location** of functional groups in hydroxy and amino acids is responsible for intramolecular cyclization which results in formation of cyclic esters **lactones** and cyclic amides **lactams**:

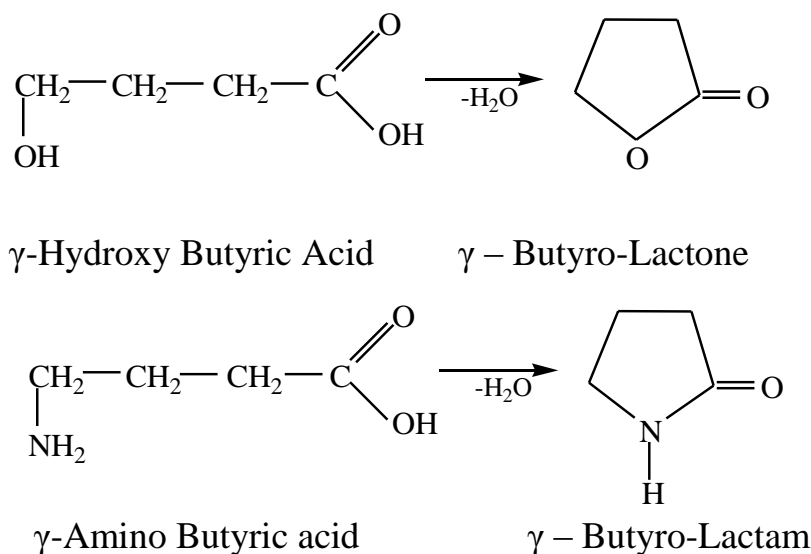

These reactions are favored energetically due to high stability of five membered cycles.

12.4. Amino Alcohols and their Biological Functions

Amino alcohols involved in metabolic processes in vivo are:

- colamine;
- choline;
- catecholamines (dioxypheylamine, adrenaline, noradrenaline).

Colamine and choline are contained in complex phospholipids; they are compartments of cell membranes. In vivo they are synthesized from α -amino acid serine.

Pathway of Serine Metabolism

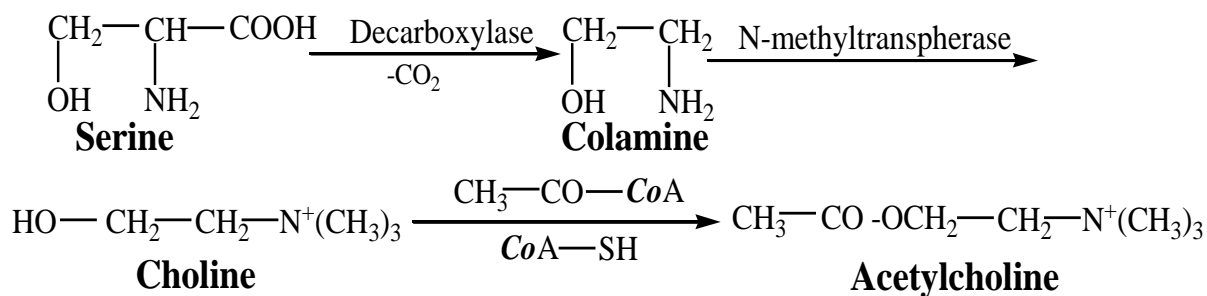

Catecholamines are the products of phenylalanine metabolic pathway:

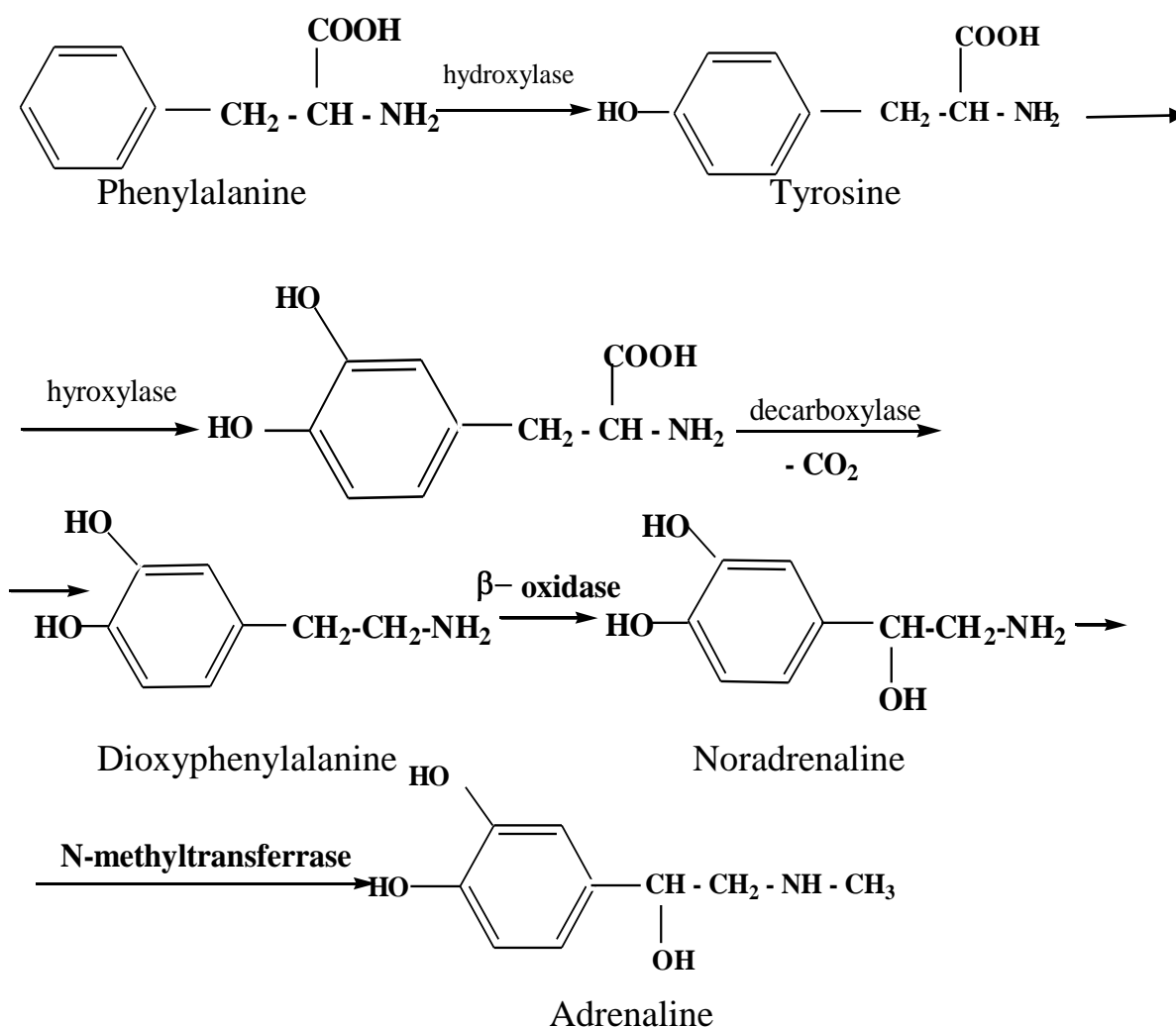



Adrenaline and noradrenaline are hormones which are secreted by adrenal gland. If you experience a sudden fright, a trace of adrenaline immediately flows and the result include a strengthen heart-beat, a rise in blood pressure, and a release of glucose into circulation from storage — all of which get the body ready to respond to the threat. Some people need to get their adrenaline flowing. Usually they go into extreme kinds of sport (alpinism, jumping with parachutes and so on).



12.5. Laboratory Work

ALIPHATIC HETERO FUNCTIONAL COMPOUNDS

Test 1. Lactic acid decomposition catalyzed by concentrated sulfuric acid

Pour 1 ml of lactic acid into a test tube and add 1 ml of concentrated sulfuric acid into it. Heat a mixture up to the boiling point. Try to ignite a liberated carbon monoxide. Write the equation for the performed reaction.

Test 2. Citric acid decomposition

Put some citric acid crystals into a dry test tube and treat them with 10 drops of concentrated sulfuric acid. Heat the prepared mixture with the help of spirit-lamp and use a gas-removing tube to pass the eliminated gas through barium hydroxide solution. After a solution turns turbid that proves CO₂ elimination, insert the gas-removing tube into a basic iodine solution. When you prepare iodine solution treat it with some drops of NaOH solution. Pay attention that iodine turns colorless in basic medium. Precipitation of pale yellow crystals gives evidence that acetone is the final product of citric acid thermal decomposition.

Citric acid is α -hydroxy acid, which undergoes decomposition under heating catalyzed by concentrated sulfuric acid according to the equation:

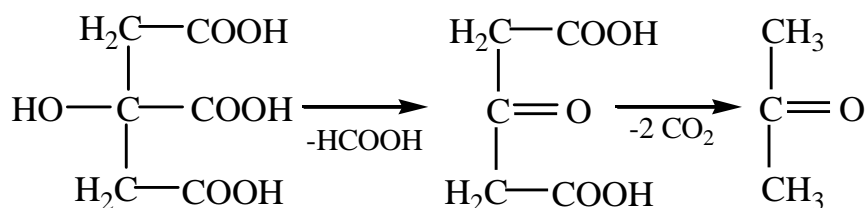

Citric acid

Acetone

Test 3. Test reaction for α -hydroxy acids with iron (III) chloride reagent

Pour 0.5 ml of 5 % phenol solution into a test tube and treat it with 1–2 drops of 1 % FeCl_3 solution. When a solution turns violet, treat it with 1–2 drops of lactic acid. What can you see? A solution changes its color when α -hydroxy acid displaces phenol in a coordination compound according to the scheme:

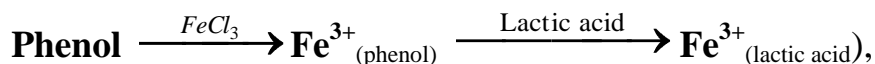

where $\text{Fe}^{3+}_{(\text{phenol})}$ and $\text{Fe}^{3+}_{(\text{lactic acid})}$ are complexes of iron (III) with phenol and lactic acid respectively.

Test 4. Preparing of Pheling's reagent

Mix 0.5 ml of 2 M copper (II) sulfate solution with 0.5 ml of 2 M sodium hydroxide solution. Treat the prepared precipitate with 3 % sodium potassium tartrate solution. Heat the mixture up to the boiling point. What can you see?

Test 5. Preparing of barium citrate salt

Put several crystals of citric acid into a dry test tube and dissolve them in distilled water. Neutralize a prepared solution by 10% ammonia solution and treat it with 0.5 ml 5 % BaCl_2 solution. Heat the prepared mixture up to the boiling point. What can you see? Write an equation for the reaction occurred. Pay attention that the prepared precipitate is soluble in cold water.

Test 6. The evidence of two carboxyl groups in tartaric acid molecule

Pour 2-3 drops of 15% tartaric acid solution into a test tube and treat it with 2 drops of 5% KOH solution. Stir a mixture. Cool a test tube with cold tap water and rub a test tube with a glass stick. After white crystals of acidic tartrate precipitate from the solution dissolve them in 5-7 drops of KOH solution. Dissolving process occurs because neutral salt of the tartaric acid is readily dissolved in water. Write the equations of the performed reactions.

12.6. Exercises for the Self-control

1. Define and describe the following terms:

- | | |
|------------------------|---------------------|
| a) stereogenic center; | b) chiral molecule; |
| c) enantiomers; | d) diastereomers; |
| e) plane of symmetry; | f) racemic mixture. |

2. Which of the following substances can exist in optically active forms?

- | | |
|-------------------------|-------------------------|
| a) 2,2-dichloropropane; | b) 1,2-dichloropropane; |
| c) oxaloacetic acid; | d) lactic acid; |
| e) choline; | f) malic acid. |

3. Draw the Fischer projections for optical isomers of the following compounds:

- | | |
|-----------------------|-----------------|
| a) α -Alanine; | b) Lactic acid; |
| c) Tartaric acid; | d) Threonine. |

Mark the stereogenic centers with asterisks.

4. Write the formulas for the keto and enol forms of α -ketoglutaric acid.

Explain a high content of enol form in a substance.

5. Write an equation for the decarboxylation for α -amino- β -hydroxypropionic acid.

6. Write an equation for the γ -aminohexanoic acid lactime preparing.

7. Write an equation for the γ -hydroxypentonic acid lactone preparing.

CHAPTER 13 HETEROFUNCTIONAL AROMATIC AND HETEROAROMATIC COMPOUNDS

After reading this chapter, you should be able to:

- define heterofunctional compounds and give their examples;
- define chiral molecules and describe their specific properties;
- be able to write the Fisher's projections of enantiomers and diastereomers;
- discuss specific properties of hydroxo-, amino and oxo acids respectively to α , β and γ location of their functional groups;
- discuss the pathways of serine and phenylalanine metabolism.

13.1. Heterofunctional Aromatic Compounds

The recent years are characterized by the rapid development of new technologies and assays for new drugs production. The discovery of new classes of chemical compounds for fighting numerous diseases is predominated by studying their chemical structure and physiochemical properties. Never the less the groups of medicines, that are traditionally applied for treating people, are of a big practical use. Among them are medicines that contain benzene ring. Let us start to review the benzene ring containing drugs beginning from the derivatives of **para-amino benzoic acid (PABA)**:

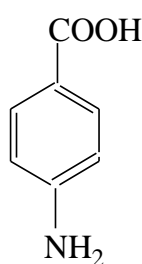

PABA

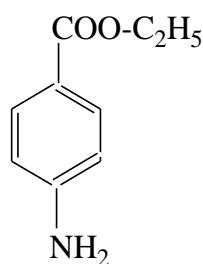

Anesthesine

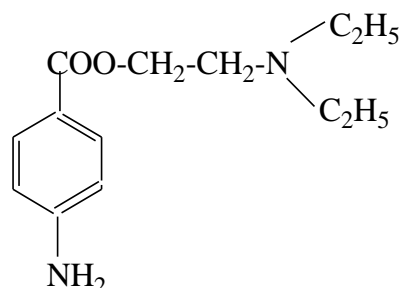

Novocain

Anesthesine and **novocain** are used as local anesthetics, applied to desensitize a particular region of the body to pain.

The introduction of the **sulfa drugs** in the 1930s hailed the beginning of modern drug therapy. Before their introduction, even a minor bacterial infection could

become potentially life threatening. Because no one understood how they worked, at first, people, even physicians, considered sulfa drugs as almost magical. Sulfa drugs are the derivatives of **sulfanilic acid**, and they are named **sulfanilamides**:

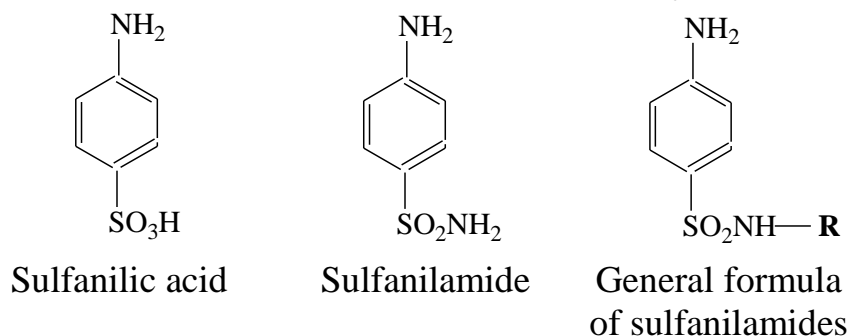

Sulfanilamide was the first drug of this group. It was synthesized in 1906 and used as a dye. Only in 1935 antibacterial activity of sulfanilamide was discovered. Nowadays more than 100 sulfanilamides are produced.

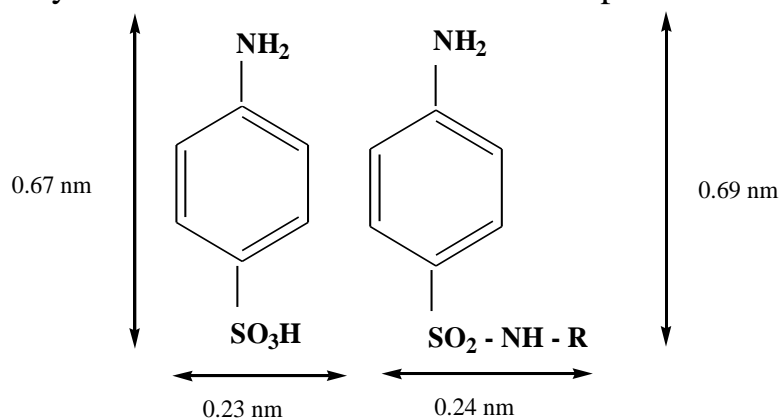

Mechanism of antibacterial activity. Sulfanilamides are drugs that exhibit high antibacterial activity. Bacteria require PABA to biosynthesize folic acid, necessary for their living. Sulfanilamides and PABA are so similar that bacteria mistake them for PABA.

In the body sulfanilamides retard biosynthesis of folic acid, thus decreasing bacterial growth and allowing the body's natural defenses to affect a cure.

Here is the list of sulfanilamides with prolonged activity:

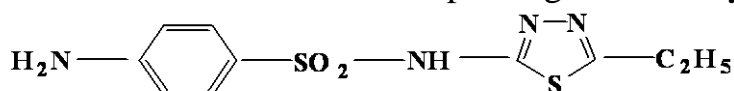

Aethasol

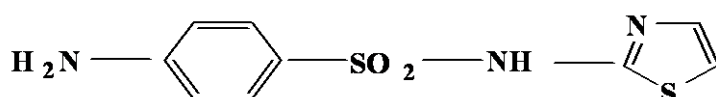

Norsulfasol

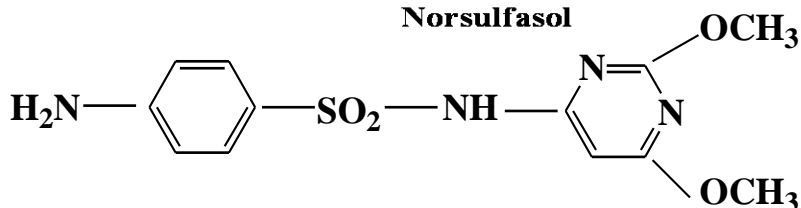

The derivatives of **salicylic acid** are applied in different branches of medicine. The most popular drug of this group is **aspirin** or **acetylsalicylic acid**. Salicylic acid and its derivatives are mild non-addictive analgesics. Aspirin is also used to improve rheological properties of blood.

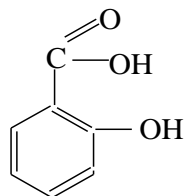

Salicylic acid

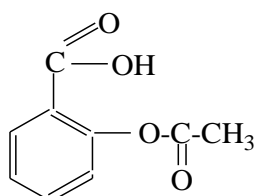

Aspirin

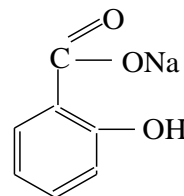

Sodium salicylate

Other derivatives of salicylic acid that are applied in modern medicine are:

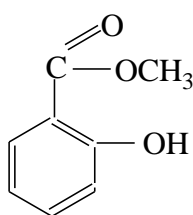

Methyl salicylate

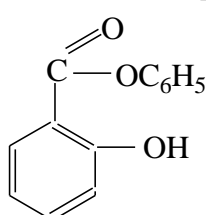

Phenyl salicylate

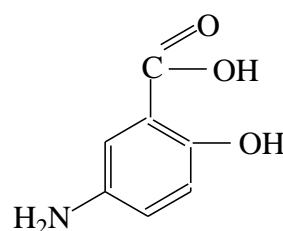

p-Amino salicylic acid

Phenyl salicylate is applied for disinfection of intestinal tract; **p-amino salicylic acid** is used as anti-TB drug.

13.2. Aromatic Heterocycles with One Nitrogen Atom

From an organic chemist's point of viewpoint, heteroatoms are atoms other than carbon or hydrogen that may be present in organic compounds. The most common heteroatoms are oxygen, nitrogen, and sulfur. In heterocyclic compounds, one or more of these heteroatoms replaces carbon in a ring.

Heterocycles form the largest class of organic compounds. In fact, most natural products and drugs contain heterocyclic rings; indeed, well over half of all organic chemical publications deal in one way or another with heterocycles. Much more important are the aromatic heterocycles that are N-containing heteroaromatic compounds.

Five-membered Cycles with one Nitrogen Atom

Now let us examine five-membered heteroaromatic compounds **pyrrole** and **indole**:

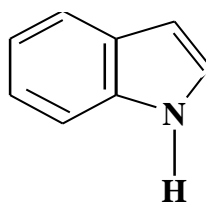
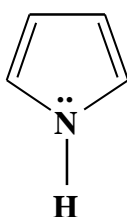

Pyrrole

Indole

In pyrrole, the unshared electron pair of nitrogen is part of the aromatic 6 π electron system. Its protonation would destroy the aromatic system, thus losing aromaticity (*acidophobic compound*). Hence pyrrole is a very weak base, in very strong acids it is protonated on carbon:

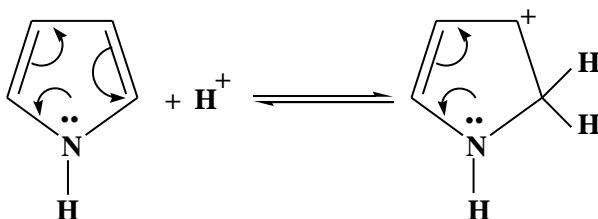

Pyrrole is much more reactive than benzene toward electrophilic substitution. Here are typical examples:

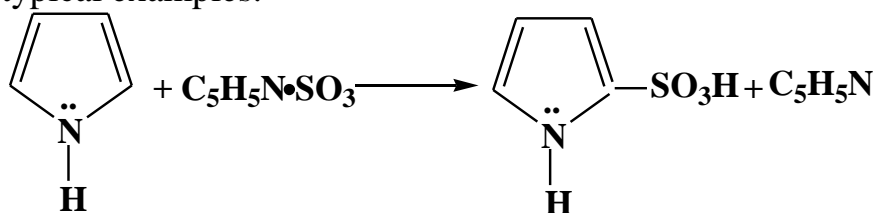

α -pyrrole sulfonic acid

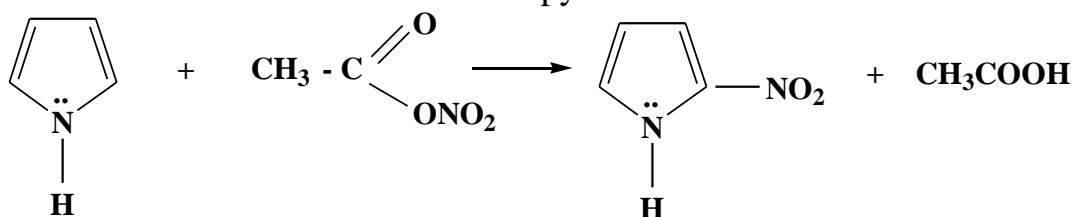

α -nitro pyrrole

Porphine is a compartment of hemoglobin, cytochromes and chlorophyll. Porphine contains four pyrrole rings in conjugation; its stabilization energy is 840 kJ/mol.

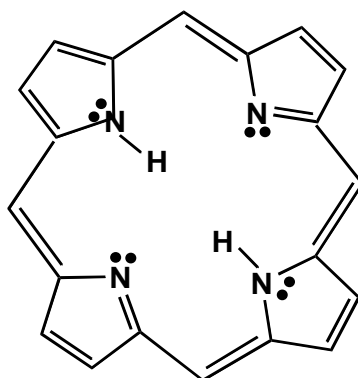

In indole molecule a benzene ring is fused to pyrrole. Electrophilic reagents are directed to C-3 (β -position):

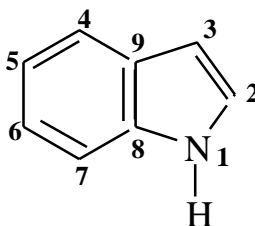

The scheme of electrophilic substitution can be represented as follows:

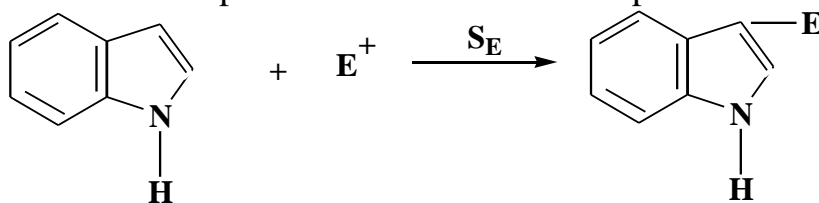

The indole ring occurs in several important natural products. Here are the examples:

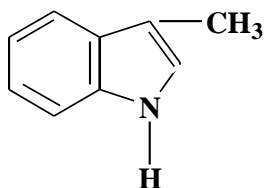

Skatole is a final product of decay

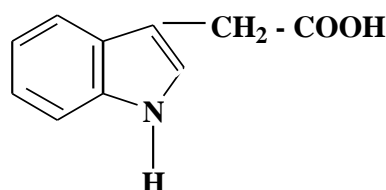

3-Indolyl acetic acid is a plants growing hormone

Tryptophan is the essential amino acid involved in proteins biosynthesis:

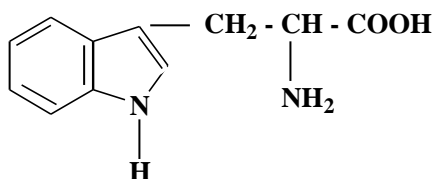

Tryptophan metabolic pathways

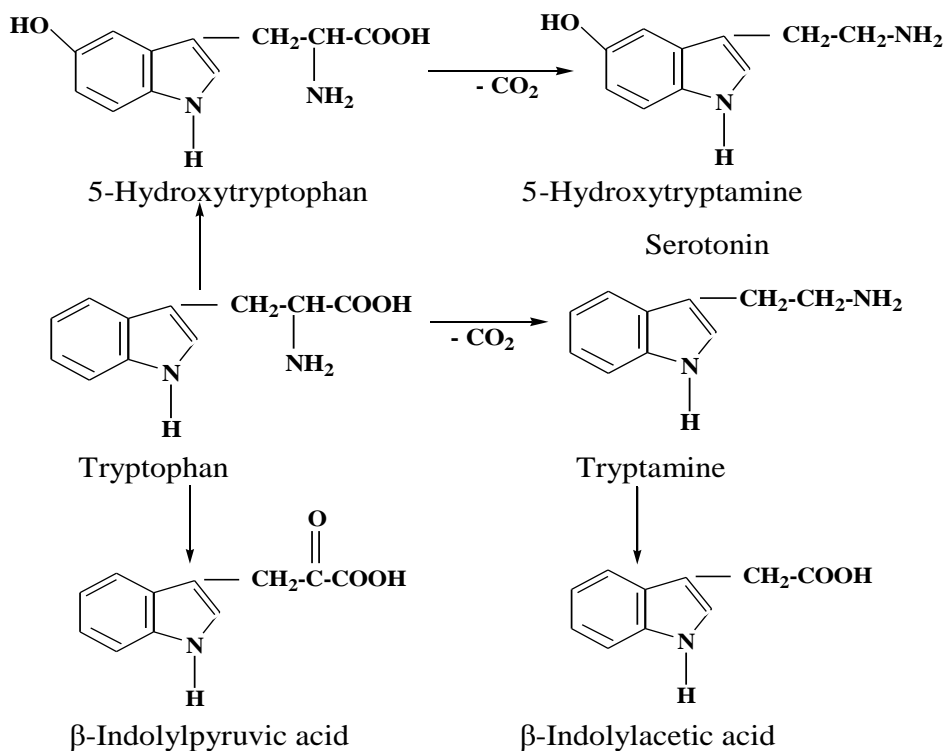

Serotonin is a neurotransmitter and vasoconstrictor active in the central nervous system. The disturbance of its metabolism may course schizophrenia.

The six-membered cycles with one nitrogen atom the most important are pyridine and quinoline:

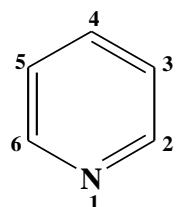

Pyridine

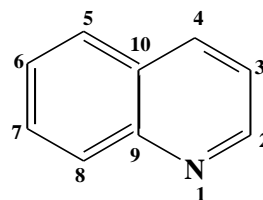

Quinoline

Pyridine has a structure similar to that of benzene, except that one CH unit is replaced by a nitrogen atom. Because of the similarities in bonding, pyridine resembles benzene in shape. It is aromatic, and tends to undergo substitution rather than addition reactions. Nitrogen atom attracts aromatic 6 π electron system toward itself thus deactivating pyridine cycle to electrophilic substitution reactions. They can run under drastic conditions:

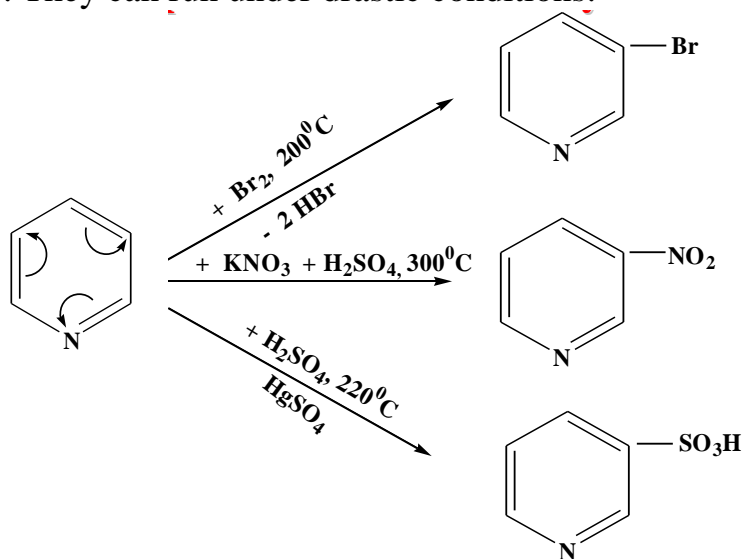

Although resistant to electrophilic substitution, pyridine undergoes nucleophilic substitution. The pyridine ring is partially positive (due to electron withdrawal by the nitrogen) and is therefore susceptible to attack by nucleophiles. Here are two examples:

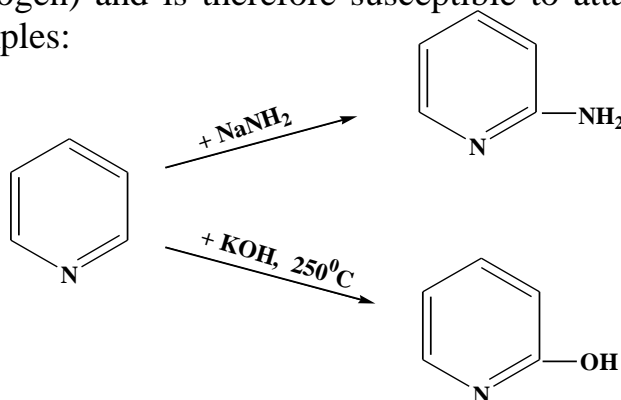

Pyridine is a weakly basic tertiary amine, with $pK_a = 5.29$. It is much weaker base than aliphatic amines ($pK_a \approx 10$). Pyridine reacts with strong acids to form pyridinium salts and hydroxides:

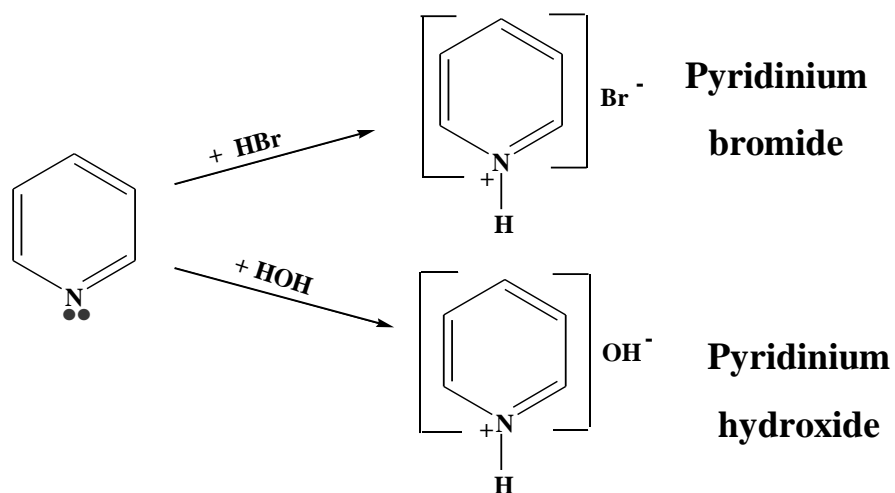

Nitrogen atom in pyridine exhibits nucleophilic properties and undergoes alkylation that results in the formation of alkylpyridinium salts:

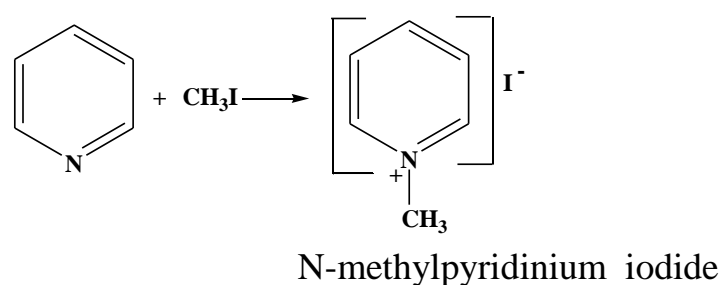

Due to positively charged nitrogen atom these cycles are able to add nucleophilic reagents (for example hydride-ion H⁻):

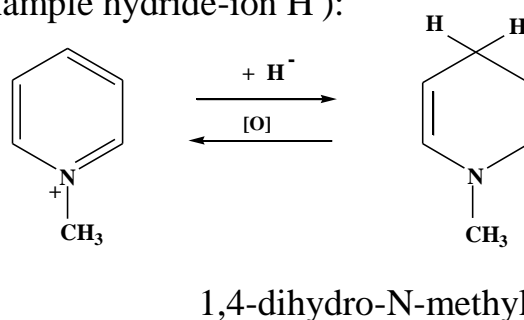

Pyridine is readily reduced to piperidine:

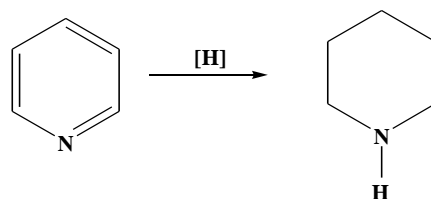

Piperidine

Promedole (narcotic analgesic) is a derivative of piperidine:

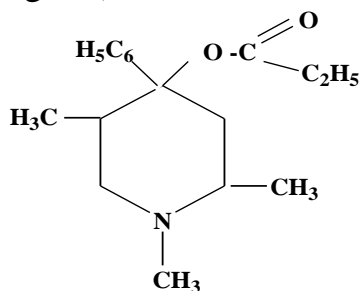

Bioactive pyridine derivatives are widespread in nature:

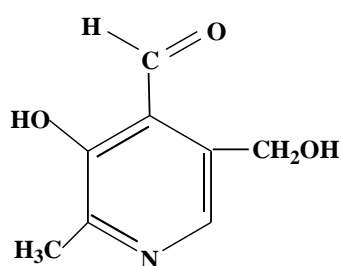

Pyridoxine (vitamin B₆)

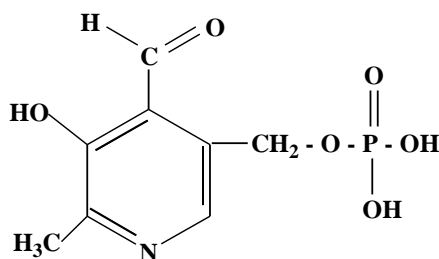

Pyridoxine phosphate (a coenzyme)

Pyridine ring is contained in three carboxylic acids, which are the products of picolines side-chain oxidation:

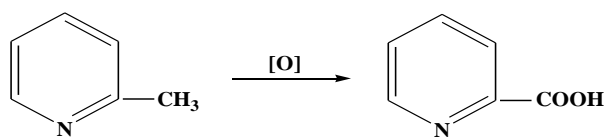

α -Picoline

Picolinic acid

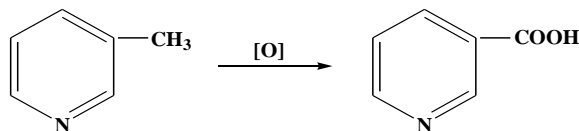

β -Picoline

Nicotinic acid

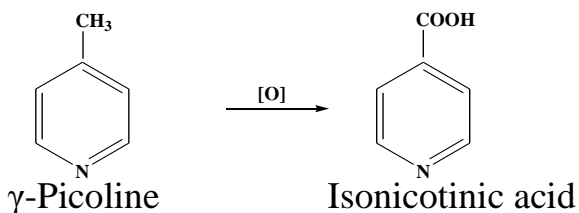

γ -Picoline

Isonicotinic acid

Nicotinic acid and nicotinamide are the components of vitamin PP essential in the human diet to prevent the disease **pellagra**:

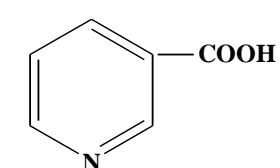

Nicotinic acid

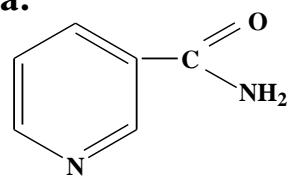

Nicotinamide

(Main component of coenzymes NAD and NADP)

The derivatives of isonicotinic acid are applied as drugs for the treatment of tuberculosis (TB):

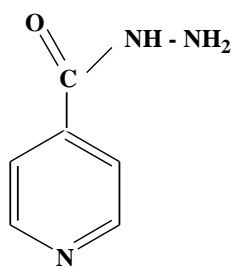

Isoniaside

Hydrozide of isonicotinic acid

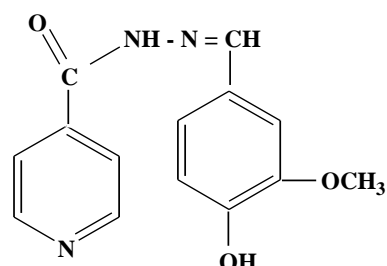

Phthivaside

(a product of isoniaside condensation with vanillin)

13.3. Aromatic Heterocycles with Two Nitrogen Atoms

Five-membered cycles with two nitrogen atoms are named azoles:

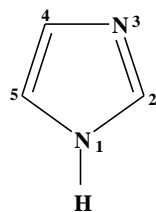

Imidazole

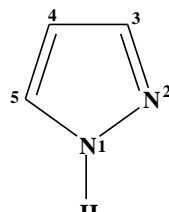

Pyrazole

Azoles exhibit acid-base duality because contain both NH-acid center and ammonium basic center (N-3):

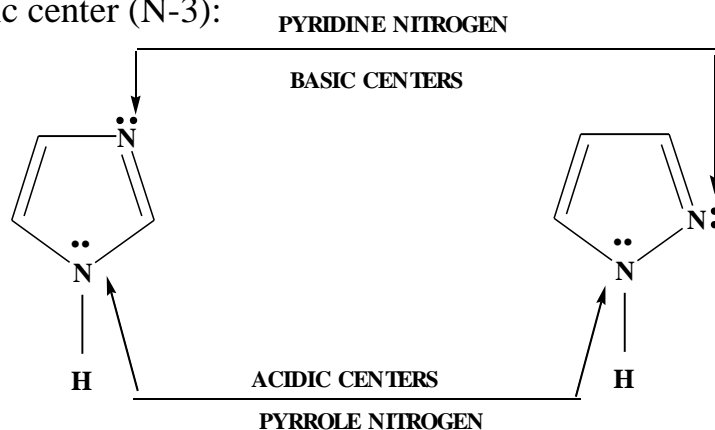

According to Brønsted theory amphoteric properties of organic compounds are responsible for hydrogen bond formation. Protons can easily migrate among associated molecules, which give rise to *prototropic tautomerism*:

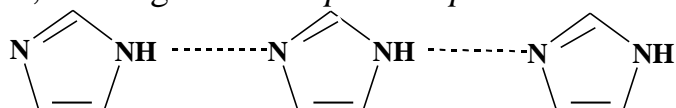

Prototropic tautomers are structural isomers that differ in location of proton and a double bond:

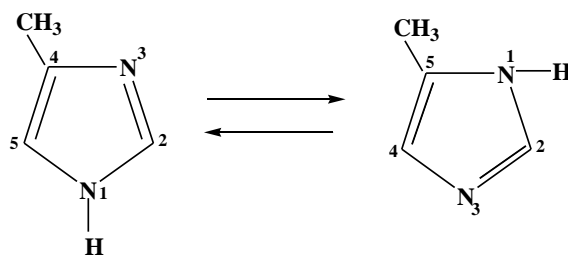

Imidazole ring systems occur in nature. For example, its skeleton is present in the amino acid histidine:

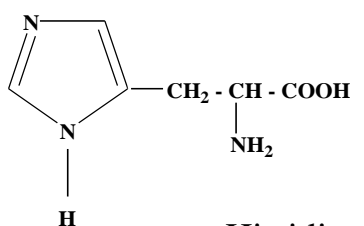

Histidine

Histidine is found abundantly in hemoglobin; it has been used in the treatment of rheumatoid arthritis, allergic diseases, ulcers & anemia. A deficiency can cause poor hearing.

Decarboxylation of histidine gives biological amine histamine, which is a hormone controlling digestion. It is also responsible for allergic reactions.

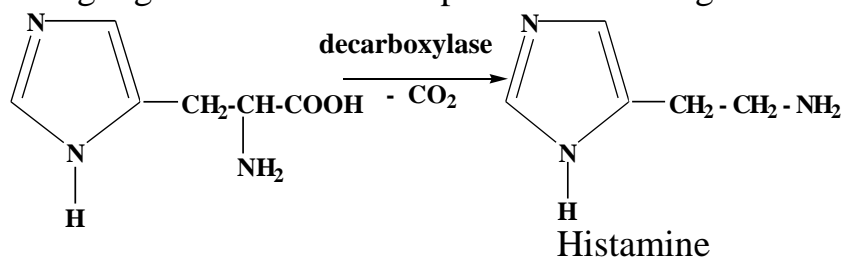

Histamine

Pyrazole and its derivatives do not occur in nature; they are applied to produce non-narcotic analgesics:

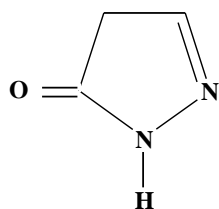

Pyrazalone-5

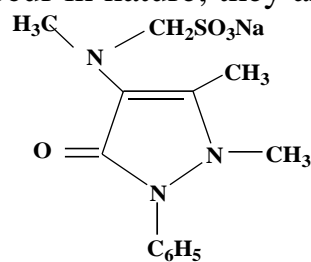

Analgine

Among six-membered cycles with two nitrogen atoms pyrimidine and purine are of most biological importance:

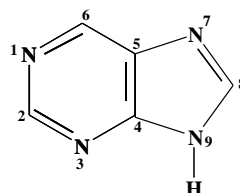
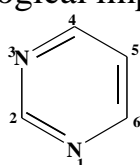

Pyrimidine

Purine

Their hydroxyl derivatives exhibit rather strong acidic properties. For example, 2, 4, 6-trihydroxy pyrimidine (barbituric acid) is stronger acid than CH_3COOH . Barbituric acid was first synthesized in 1863 by Adolf von Baeyer by condensation of malonic ester with urea:

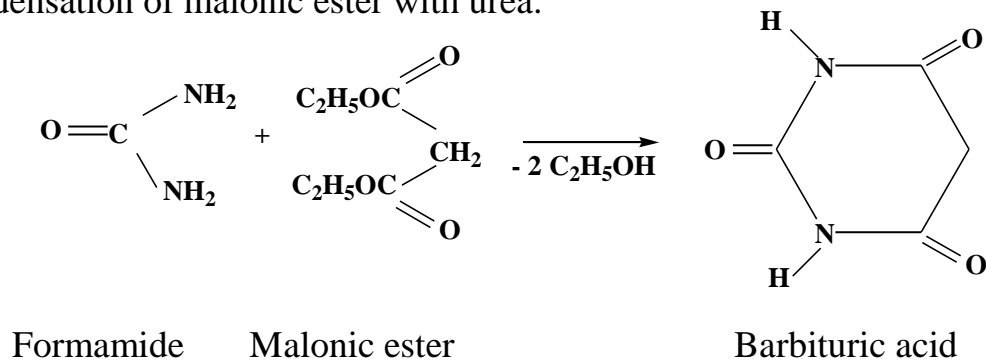

Barbituric acid is a nonsystematic name, and this fact gave rise to different hypothesis that are popular among chemists. Some admitted romantics theorize that von Baeyer was courting a woman named Barbara and named the compound in her honor. Less romantic chemists came to belief that the acid was named barbituric because he synthesized it on Saint Barbara day (December 4).

Barbituric acid exhibits keto-enol and lactim-laktam of tautomerism. It was proved that enol tautomer is most acidic. Here you can see three tautomers of barbituric acid at equilibrium state:

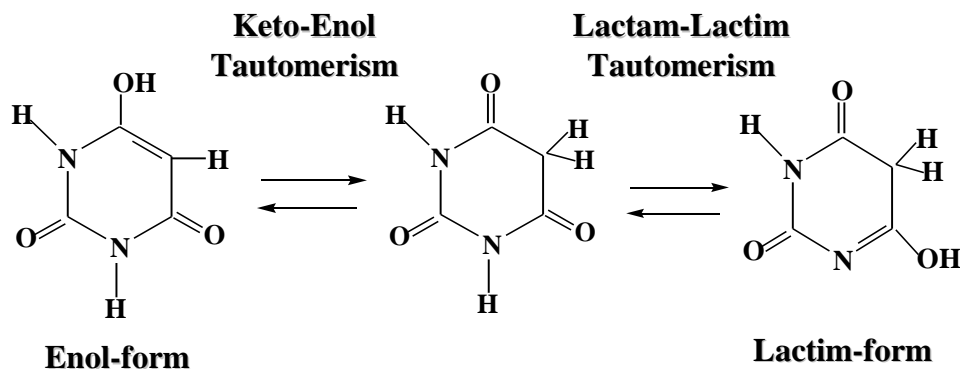

Barbiturates are the derivatives of barbituric acid that are wide applied in modern medicine. They exhibit sedative and anticonvulsant effects:

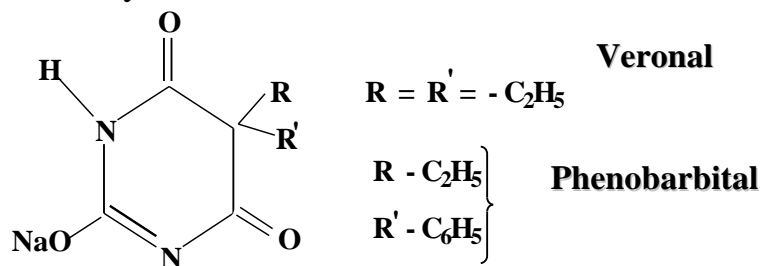

All barbiturates are addictive. Anyone taking them regularly will suffer withdrawal when they discontinue using them. Typically barbiturate addiction takes about six months of regular use.

The **purines** are another biologically important class of fused-ring heterocycles. They contain a pyrimidine ring fused to an imidazole ring:

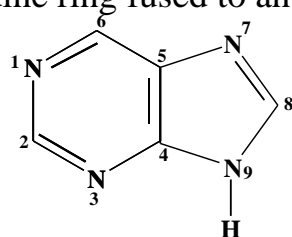

Purine

Here the purine hydroxyl derivatives are represented:

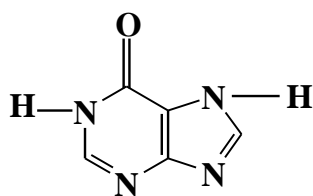

Hypoxanthine
(6-oxapurine)

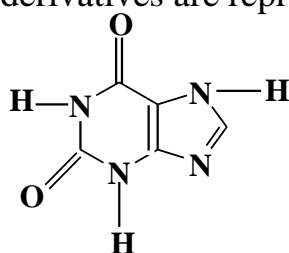

Xanthine
(2, 6-dioxapurine)

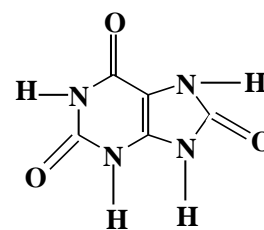

Uric acid
(2, 6, 8-trioxapurine)

The purine hydroxyl derivatives exist in several forms due to lactim-lactam and prototropic tautomerism. In this case, Prototropic tautomerism is a migration of proton between N-7 and N-9 (ten shifts per second). Hypoxanthine tautomerism is represented in the following scheme:

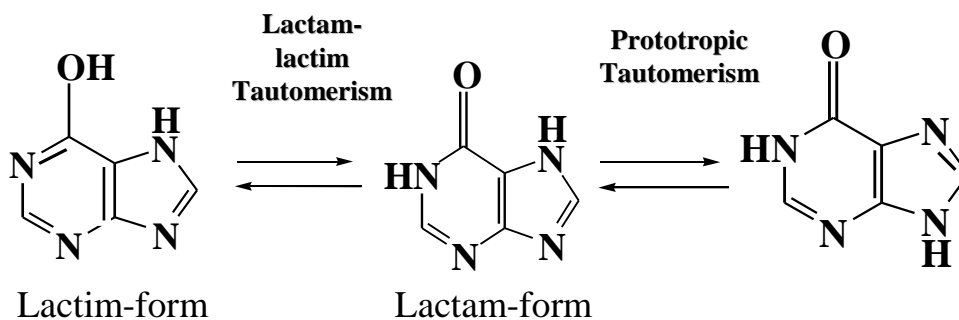

Uric acid is present in the urine of all carnivores and is the main product of nitrogen metabolism in the excrement of birds and reptiles. Its lactam and lactim forms exist at equilibrium:

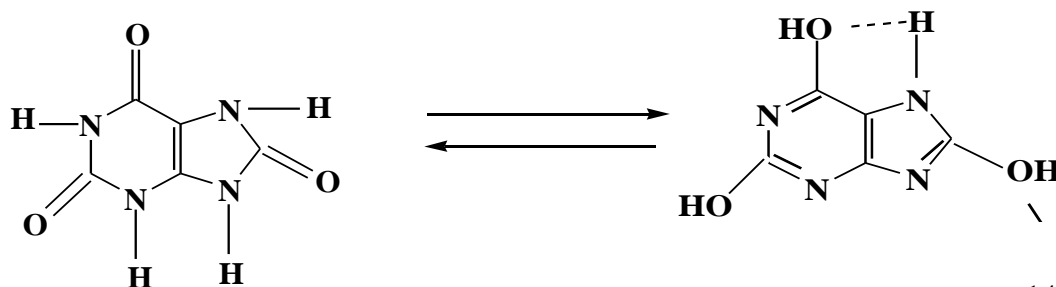

Lactam form

Lactim form

Lactim-form contains two OH-acidic centers. It's a diprotic acid. Urates are salts of uric acid. Such a disease as the gout is the result of sodium urates in joints and tendons.

Alkaloids. Alkaloids are basic N-containing compounds of plant and animal origin, which are extremely physiologically active. Purine alkaloids are xanthene derivatives. They are wide applied in medicine as drugs.

Purine alkaloids

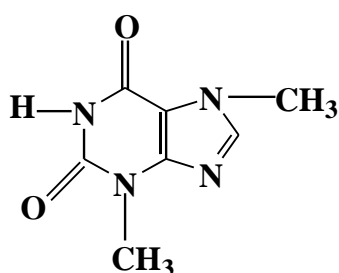

Theobromine
(contained in cacao)

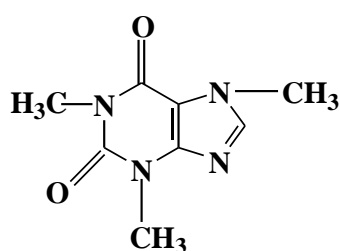

Caffeine
(contained in coffee,
tea and cola beverages)

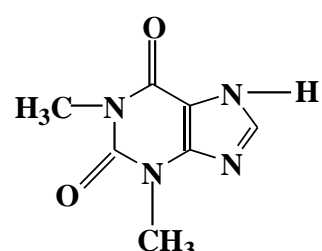

Theophylline
(contained in tea)

Caffeine is applied in medicine to increase blood pressure and stimulate heart activity. Theobromine and theophylline are diuretics.

13.4. Laboratory Work

HETERO FUNCTIONAL AROMATIC AND HETEROCYCLIC COMPOUNDS

Test 1. Nicotinic acid interaction with Cu (II) acetate

Interaction of nicotinic acid with Cu (II) acetate in acetic acid medium results in Cu (II) nicotinate precipitation. Put 5–10 mg of nicotinic acid's crystals into a test tube and dissolve them in 15–20 drops of 10 % acetic acid solution under heating. Heat a prepared solution up to the boiling point and treat it with 15–20 drops of 5 % Cu (II) acetate solution. A solution turns turbid. Blue precipitate of nicotinic acid salt appears in several minutes.

Test 2. Solubility of salicylic acid and its salts

Put some crystals of salicylic acid into a test tube and dissolve them in 2–3 ml of distilled water. Is salicylic acid soluble in water or not? Treat a prepared mix-

ture with sodium hydroxide solution. What can you see? Is sodium salicylate soluble in water or not? Add some drops of mineral acid to the solution. What can you see? Explain the result. Write the equations for the performed reactions.

Test 3. Aspirin hydrolysis

Put some aspirin crystals into a test tube and try to dissolve them in 5-6 drops of distilled water. What can you say about aspirin solubility in water? Divide the prepared solution into two test tubes and boil a mixture in the first test tube during 1–2 minutes. Cool the solution with tap water. The solutions in both test tubes treat with 2–3 drops of iron (III) chloride. What can you see? Explain the result. Write the equation for aspirin hydrolysis.

13.5. Exercises for the Self-Control

1. Write the equations of chemical reactions for pyridine sulfonation and hydroxylation. Name the mechanism of the given reactions.

2. Write the equation for tryptophan decarboxylation. What enzyme is involved into this process? Name a prepared bioactive amine.

3. Why imidazole and pyrazole molecules are associated under physiological conditions? Write formulas for imidazole's cluster.

4. Describe hypoxanthine lactam-lactime and prototropic tautomerism.

5. Write the equation for aspirin acid-catalyzed hydrolysis. Name the products. How to check up its quality?

6. Write structural formulas for nicotinic acid and its amide. What vitamin is composed of these substances?

7. Write a structural formula for uric acids. Describe its lactam-lactim tautomerism. What disease is initiated by disturbance of urates metabolism?

8. Write structural formulas for xanthene and purine alkaloids (caffeine, and thiobromine).

PART III BIOPOLYMERS AND BIOREGULATORS

CHAPTER 14 LIPIDS

After reading this chapter, you should be able to:

- define lipids and their classification;
- describe structure of simple and complex saponifiable lipids;
- discuss chemical properties of fats, oils and phospholipids.

14.1. Classification of the Lipids

Lipids (from *greek* "lipos" — fat) are constituents of plants and animals that are characterized by their solubility properties. In particular, they are insoluble in water but soluble in nonpolar organic solvents. Lipids can be extracted from cells and tissues by organic solvents (e.g. ether, chloroform, acetone and benzene). Solubility properties distinguish lipids from other classes of natural products: carbohydrates, proteins and nucleic acids (they are in general soluble in water and insoluble in organics).

The lipids are a large and diverse group of naturally occurring organic compounds. There is great structural variety among the lipids, as will be demonstrated in the following sections.

Lipids perform several biological functions:

- triglycerides serve as reserve energy of the body. The complete oxidation of triglycerides provides high caloric content, about 38 kJ/g, compared with 19 kJ/g for the breakdown of carbohydrates and proteins;
- phospholipids are important components of cell membranes structure in eukaryotic cells; they regulate membrane permeability;
- triglycerides are the source of water in a body. When 100 g of lipids are oxidized — 107 g of water are released. Oxidation of the same amount of proteins and carbohydrates gives only 40–50 grams of water.
- serve as solvents for fat soluble vitamins like A, D, E, K;
- act as electrical insulators to the nerve fibres, where the myelin sheath contains lipids;
- lipids in the body perform thermal insulation function. They protect organs from both hypothermia and overheating;

- lipids are responsible for the body shape. A few studies have suggested that total dietary fat intake is linked to an increased risk of obesity and diabetes;
- some lipids like prostaglandins and steroid hormones act as cellular metabolic regulators.

Lipids fall into two categories:

- a) which can be hydrolyzed or saponified (**saponifiable lipids**);
- b) which cannot be hydrolyzed (**nonsaponifiable lipids**).

The classification of saponifiable lipids is given in Figure 14.1.

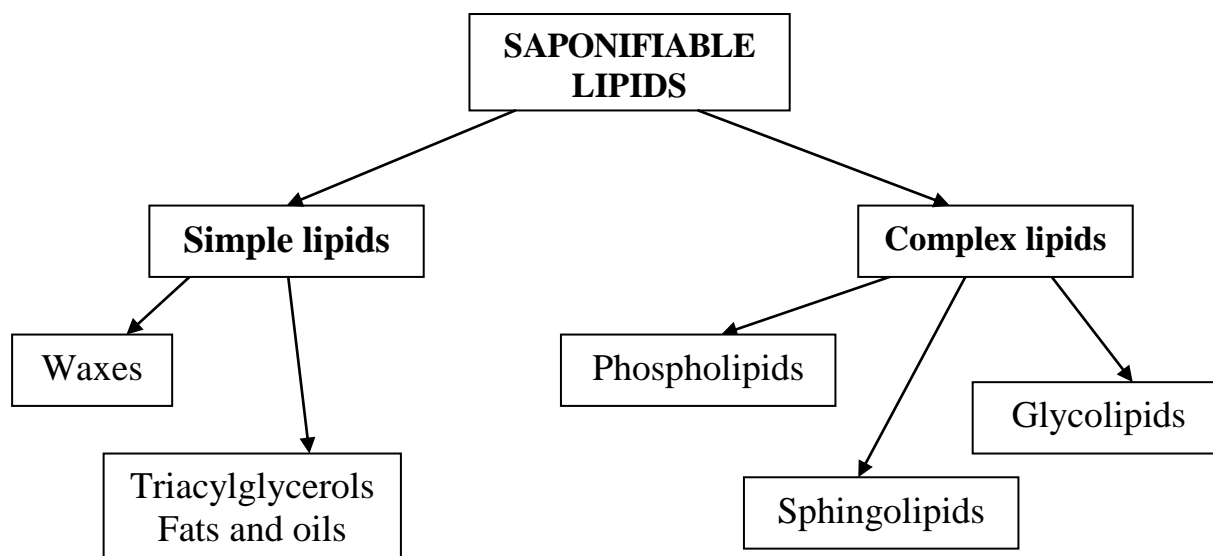
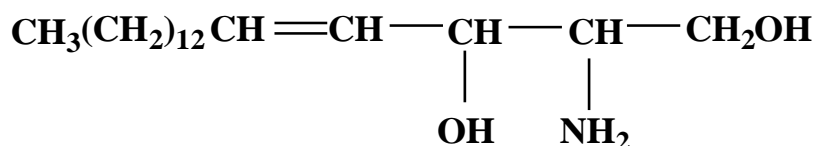

Figure 14.1 — Classification of saponifiable lipids

Simple saponifiable lipids are composed of three chemical elements such as carbon, hydrogen and oxygen while complex saponifiable lipids contain nitrogen and phosphorus as well.

The structural bases for all saponifiable lipids are different alcohols:

- long-chain monohydric alcohols such as mericyl alcohol $C_{30}H_{61}OH$ or cetyl alcohol $C_{16}H_{33}OH$
- trihydric alcohol glycerol,
- long-chain dihydric amino alcohol with one double bond, named sphingosine:



In lipids' molecules **alcohols are acylated by fatty acids**. Fatty acids are important components of lipids (fat-soluble components of living cells) in plants, animals, and microorganisms. They are not found in a free state in nature; commonly they exist in combination with the alcohol glycerol in the form of triglycerides. They are important sources of fuel because, when metabolized,

they yield large quantities of ATP. Many cell types can use either glucose or fatty acids for this purpose. In particular, heart and skeletal muscle prefer fatty acids. Despite long-standing assertions to the contrary, fatty acids can be used as a source of fuel for brain cells, at least in some rodents in addition to glucose and ketone bodies.

According to their chemical structure fatty acids are monocarboxylic acids with long hydrocarbon radicals that are usually unbranched. Most naturally occurring fatty acids have a chain of an even number of carbon atoms, from 10-30 carbons (most usual is 12–18). Odd-numbered fatty acids are mostly frequent in bacteria and lower plants or animals.

Note that there are two groups of fatty acids — **saturated** and **unsaturated**. If the carbon-carbon bonds are all single, the acids are **saturated**. They have no unsaturated linkages and cannot be altered by hydrogenation or halogenation. When double bonds are present, fatty acids are said **unsaturated** (Figure 14.2).

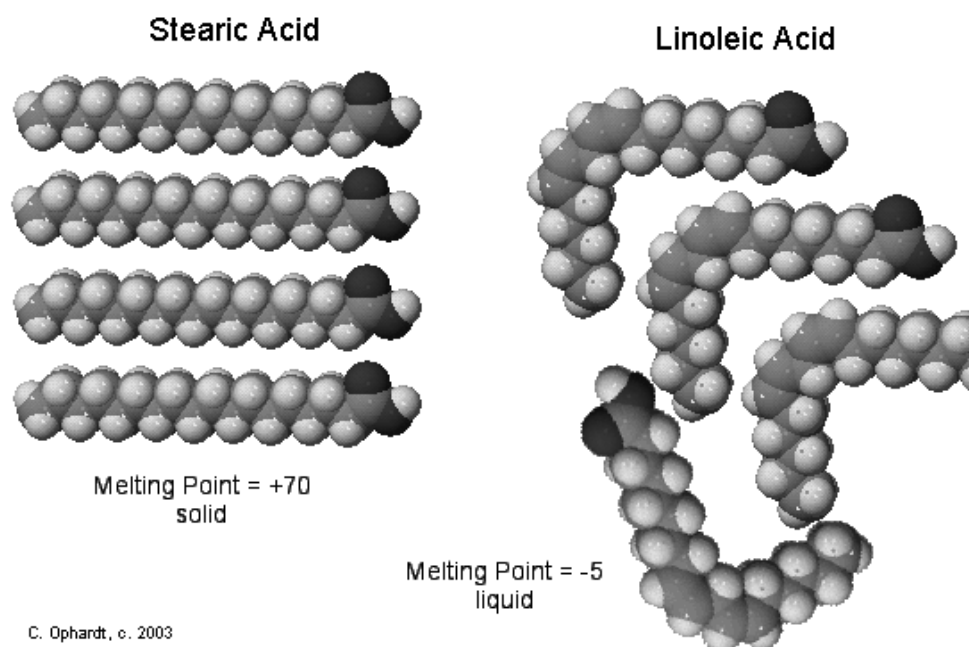

Figure 14.2 — Stick-and-ball models of stearic and linoleic acids

They are **monounsaturated** if only one double bond is present and **polyunsaturated** if they have two or more double bonds generally separated by a single methylene group (methylene-interrupted unsaturation). The double bonds have usually a *cis* configuration (Figure 14.3).

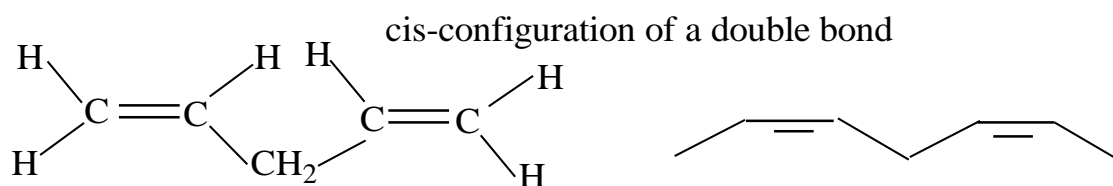



Figure 14.3 — Cis-configuration of a double bond

Straight- or normal-chain, saturated components make up 10-40% of the total fatty acids in most natural lipids. They are white solids insoluble in water. The most common saturated fatty acids are listed in Table 14.1.

Palmitic acid is usually considered the most abundant saturated fatty acid in nature, and it is found in appreciable amounts in the lipids of animals, plants and lower organisms. It comprises 20–30 % of the lipids in most animal tissues, and it is present in amounts that vary from 10 to 40 % in seed oils. Among commercial sources, it is most abundant in palm oil (40 % or more). It has a vital function in cells in specific proteolipids, where it is linked to internal cysteine residues via thioester bonds.

Stearic acid is the second most abundant saturated fatty acid in nature, and again it is found in the lipids of most living organisms. In lipids of some commercial importance, it occurs in the highest concentrations in ruminant fats (milk fat and tallow) or in vegetable oils such as cocoa butter, and of course in industrially hydrogenated fats. It can comprise 80 % of the total fatty acids in gangliosides. Relatively high proportions of stearic acid subjected to enzymatic desaturation (to oleic acid), in comparison to other saturated fatty acids.

Table 14.1 — The most common saturated fatty acids

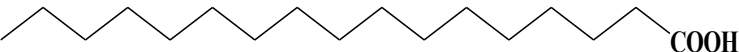
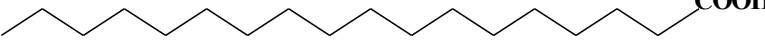
| Systematic name | Common name | Formulas |
|--------------------|---------------|---|
| Hexadecanoic acid | Palmitic acid | $\text{CH}_3(\text{CH}_2)_{14}\text{COOH}$  |
| Heptadecanoic acid | Margaric acid | $\text{CH}_3(\text{CH}_2)_{15}\text{COOH}$  |
| Octadecanoic acid | Stearic acid | $\text{CH}_3(\text{CH}_2)_{16}\text{COOH}$  |

Unsaturated fatty acids are pale yellow liquids insoluble in water and soluble in organics. To mark the position of double bonds in their molecules the carbon atoms are counted from the carboxyl group that put the emphasis on the double bond closest to this group.

For example, in oleic acid molecule the carbon-carbon double bond is between carbons 9 and 10:

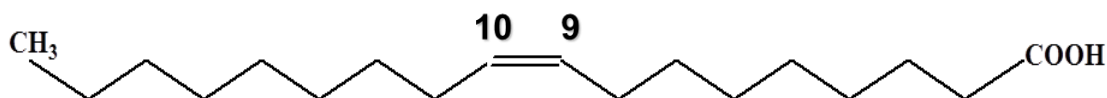

Since biological fatty acids can be of different lengths, the last position is labeled as an omega " ω ", the last letter in the Greek alphabet. Since the physiological properties of unsaturated fatty acids largely depend on the position of the first unsaturation relative to the end position but not the carboxyl group the "**omega nomenclature**" as a new numbering system for the unsaturation was adopted by the International Commission on Biochemical Nomenclature in 1964.

For example, oleic acid is ω -9 acid where the term ω -9 signifies that the first double bond exists as the ninth carbon-carbon bond from the terminal CH_3 end (ω) of the carbon chain. The other double bonds are deduced from the first one since in the most frequent structures the double bonds are non-conjugated and separated by a single methylene group.

Oleic acid is the most widely distributed fatty acid which is abundant in some vegetable oils (e.g., olive, palm, peanut, and sunflower seed) and which makes up about 46 percent of human fat. The most common unsaturated fatty acids are listed in Table 14.2.

Table 14.2 — The most common unsaturated fatty acids

| Systematic name | Common name | Formulas |
|-----------------------------------|------------------|----------|
| ω -9-octadecenoic acid | Oleic acid | |
| ω -6-octadecadienoic acid | Linoleic acid | |
| ω -3-octadecatrienoic acid | Linolenic acid | |
| ω -6-eicosatetraenoic acid | Arachidonic acid | |

The body can synthesize most of the fats it needs from the diet. However, two essential fatty acids, linolenic and linoleic acids, cannot be synthesized in the body and must be obtained from food. These basic fats, found in plant foods, are used to build specialized fats called omega-3 and omega-6 fatty acids. Omega-3 and omega-6 fatty acids are important in the normal functioning of all tissues of the body. Deficiencies in these fatty acids lead to a host of symptoms and

disorders including abnormalities in the liver and the kidneys, reduced growth rates, decreased immune function, depression, and dryness of the skin. Adequate intake of the essential fatty acids results in numerous health benefits. Documented benefits include prevention of atherosclerosis, reduced incidence of heart disease and stroke, and relief from the symptoms associated with ulcerative colitis, menstrual pain, and joint pain.

Arachidonic acid is a precursor of prostaglandins, which play important regulatory roles in the life processes such as digestion, blood circulation and reproduction.

In some animals, but mainly in plants and bacteria, fatty acids may be more complex since they can have an odd number of carbon atoms, branched chains or contain a variety of other functional groups, including acetylenic bonds, epoxy-, hydroxy- or keto groups and even ring structures (cyclopropane, cyclopropene, cyclopentene, furan, and cyclohexyl) or a coenzyme A moiety (acyl CoA).

14.2. Simple Saponifiable Lipids

Waxes in their most common form, are esters that consist of fatty acids esterified to long-chain alcohols. For example, cetyl palmitate is a component of spermaceti, a wax in sperm whale oil:

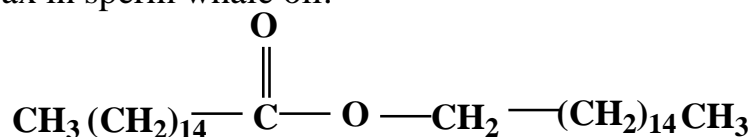

Mericyl palmitate is a component of a bee wax:

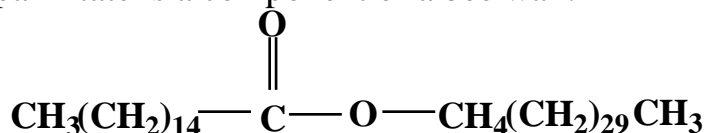

Waxes are found in animal, plant and microbial tissues and they have a variety of functions, such as acting as energy stores, waterproofing and lubrication. In nature, waxes act as protective coatings on fruit and leaves as well on fur, feathers and skin. They are used to make polishes, cosmetics, ointments and other pharmaceutical preparations as well as candles and phonograph records.



Omega-3 fatty acids are considered essential fatty acids. They are necessary for human health but the body can't make them — you have to get them through food. Omega-3 fatty acids can be found in fish, such as salmon, tuna, and halibut, other sea food including algae and krill, some plants, and nut oils. Also known as polyunsaturated fatty acids (PUFAs), omega-3 fatty acids play a crucial role in brain function, as well as normal growth and development. They have also become popular because they may reduce the risk of heart disease. The American Heart Association recommends eating fish (particularly fatty fish such as mackerel, lake trout, herring, sardines, albacore tuna, and salmon) at least 2 times a week.

Omega-3 fatty acids (also called ω -3 fatty acids or n-3 fatty acids) are polyunsaturated fatty acids (PUFAs) with a double bond (C=C) at the third carbon atom from the end of the carbon chain. The fatty acids have two

The way in which a fatty acid is named is determined by the location of the first double bond, counted from the methyl end, that is, the omega (ω -) or the *n*- end.

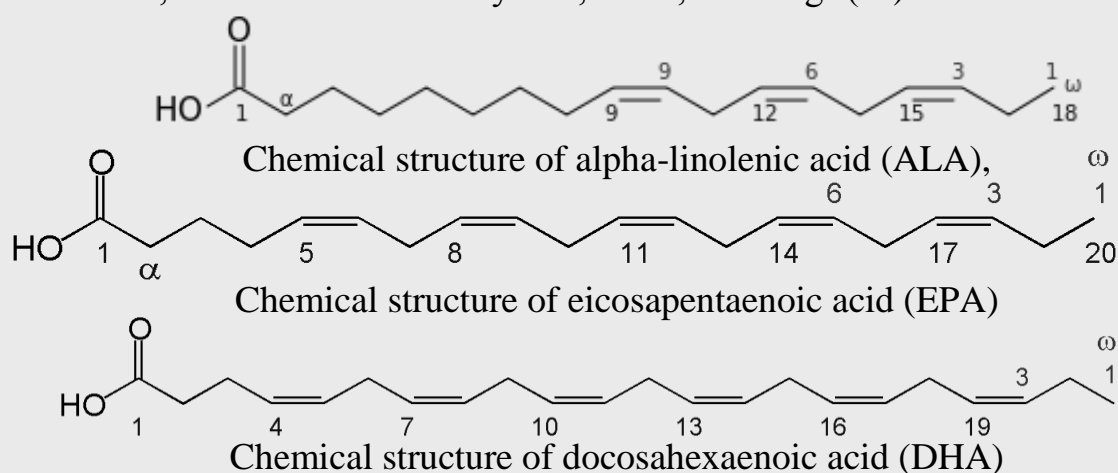

The three types of omega-3 fatty acids involved in human physiology are α -linolenic acid (ALA) (found in plant oils), eicosapentaenoic acid (EPA), and docosahexaenoic acid (DHA) (both commonly found in marine oils). Marine algae and phytoplankton are primary sources of omega-3 fatty acids.

Blood fat (triglycerides). Fish oil supplements can lower elevated triglyceride levels. Having high levels of this blood fat puts you at risk for heart disease. DHA alone has also been shown to lower triglycerides.

Rheumatoid arthritis. Fish oil supplements (EPA+DHA) can curb stiffness and joint pain. Omega-3 supplements also seem to boost the effectiveness of anti-inflammatory drugs.

Mental health. Some researchers have found that cultures that eat foods with high levels of omega-3s have lower levels of depression. Fish oil also seems to boost the effects of antidepressants and may help the depressive symptoms of bipolar disorder.

The link between omega-3 and depression has been attributed to the fact that many of the products of the omega-3 synthesis pathway play key roles in regulating inflammation such as prostaglandin which have been linked to depression.

Baby development. DHA appears to be important for visual and neurological development in infants.

Asthma. A diet high in omega-3s lowers inflammation, a key component in asthma. But more studies are needed to show if fish oil supplements improve lung function or cut the amount of medication a person needs to control the condition.

Alzheimer's disease and dementia. Some research suggests that omega-3s may help protect against Alzheimer's disease and dementia, and have a positive effect on gradual memory loss linked to aging. But that's not certain yet.

Cognitive aging. Epidemiological studies suggest that consumption of

The lipids we're most familiar with are probably dietary fats. So if you get a little hungry, and you decide you want to eat some macaroni and cheese, and you look at the nutrition label, what you'll find is that it contains 12 grams of fat per serving. It also contains 31 grams of carbohydrates and 5 grams of protein. So you have 12 grams of fat that give you 110 calories, and 36 grams of carbohydrates and protein combined, giving you 140 calories in each serving. So the fat gives you 9.2 calories per gram, while the carbohydrates and proteins give you only 3.9 calories per gram, which means that the fats contain over two times as much energy per gram! So this tells us that lipids and fats are good for storing energy, but what do they look like?

Fats and oils are familiar parts of daily life. Common fats include butter, lard, and the fatty portions of meat. Oils come mainly from plants and include corn, cottonseed, olive, peanut, and soybean oils. Although fats are solids and oils are liquids, they have the same basic organic structure. Fats and oils are triesters of glycerol and are called **triacylglycerols** or **triglycerides**. Their general formula is:

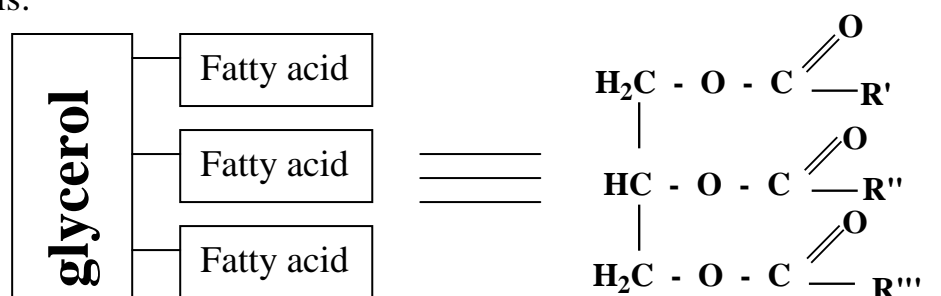

where R are radicals of fatty acids.

Triglycerides fall into two categories:

- simple that contain identical radicals of fatty acids;
- mixed that contain radicals of different fatty acids.

For examples: glyceryl tristearate is simple triacylglycerols:

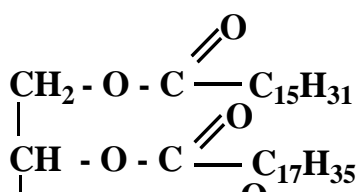
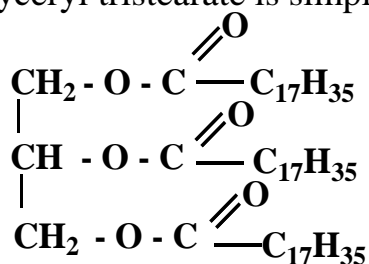

Glyceryl palmitostearooleate is an example of mixed triacylglycerols:

In general, a particular fat or oil consists, not of a single triglyceride, but of a complex mixture of triglycerides. Oils contain a much higher percentage of unsaturated fatty acids than do fats.

The analytic characteristic for fats and oils is **iodine number** – a number of grams of I_2 consumed by 100 grams of a triglyceride. For oils iodine number is greater than 70, for fats — less than 70 (Table 14.1).

Table 14.1 — Iodine numbers of fats and oils

| Fats and Oils | Iodine numbers, Iodine numbers | Fats and Oils | Iodine numbers, Iodine numbers |
|----------------------|---------------------------------------|----------------------|---------------------------------------|
| Butter | 36 | Palm oil | 145 |
| Beet tallow | 59 | Corn oil | 123 |
| Olive oil | 81 | Peanut oil | 104 |

14.3. Complex Saponifiable Lipids

Complex saponifiable lipids contain nitrogen- and phosphorous-containing fragments or sugar residues in their molecules.

Phospholipids are esters either of glycerol or sphingosine. Phospholipids generally consists of four types of components — a platform molecule that acts as an attachment point for other groups, one or more fatty acids, a phosphate group and an alcohol group. Phosphoglycerides are L-enantiomers and related structurally to fats and oils, except that one of the three ester groups is replaced by a phosphatidylamine.

Phospholipids can be categorized based on the type of platform molecule used to build the lipid. If the platform molecule is a glycerol (a three-carbon alcohol), then the phospholipid is called a phosphoglyceride. On the other hand, if the platform molecule is a sphingosine, then the phospholipid is called a sphingolipid.

In phosphoglycerides, the two fatty acids are attached via an ester bond to the C1 and C2 atoms of the glycerol while the phosphate group is attached via an ester bond to the C3 atom of the glycerol. The phosphate group can be modified with alcohols such as choline, ethanolamine, serine:

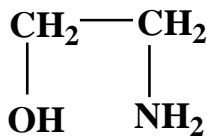

Ethanolamine (Calamine)

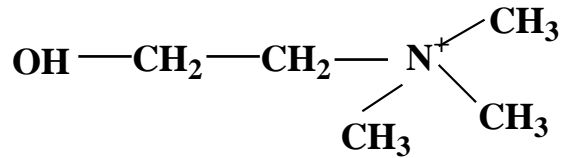

Choline

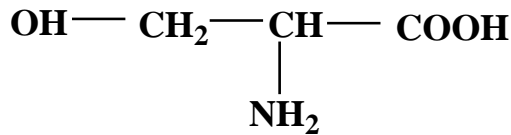

Serine

General formula for phospholipids is:

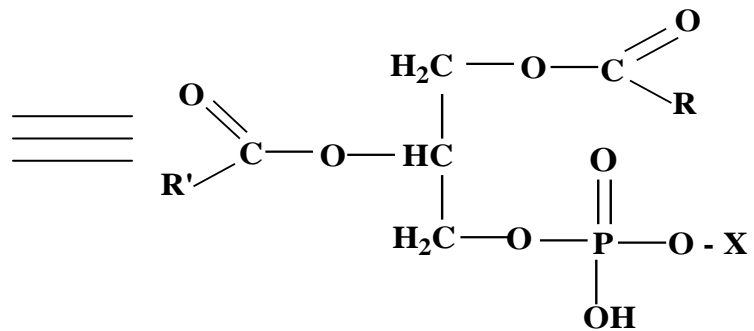
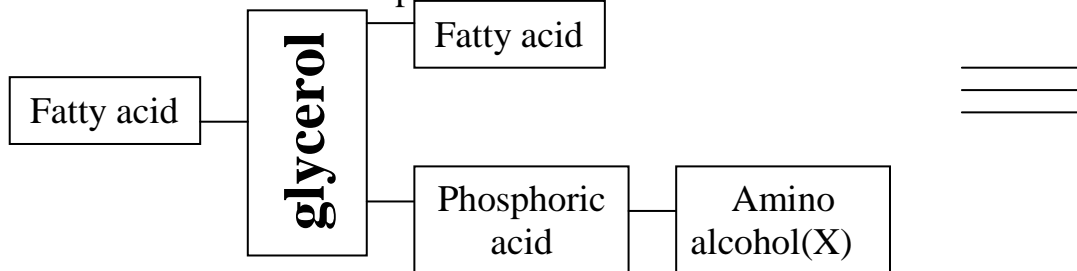

Thus phosphoglycerides naturally occurred in cell membranes are:

- phosphatidylcholine (lecithin). Lecithin (from Greek *egg yolk*) is a rich source of phospholipids. General formula for phosphatidylcholine:

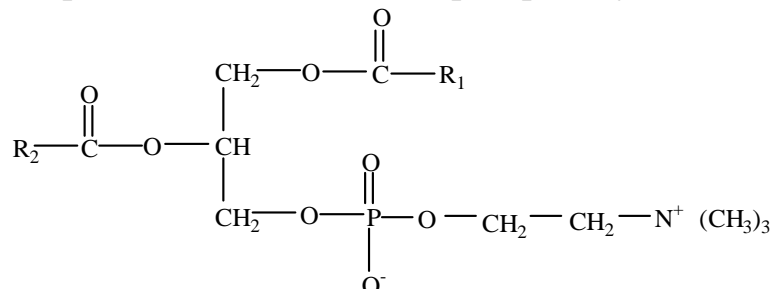

- phosphatidylserine. General formula:

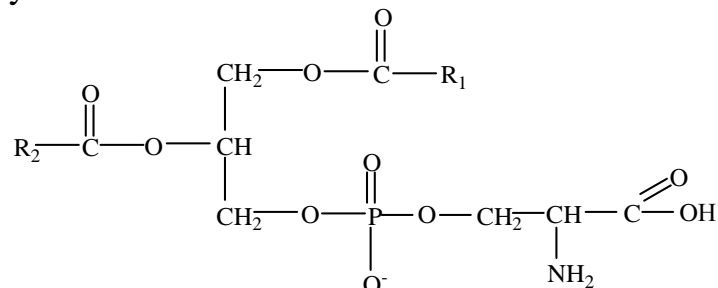

- phosphatidylethanolamine (cephalin). Cephalin (from Greek *head*) is found in brain tissue. General formula:

Phospholipids consist of a phosphate head and a hydrocarbon tail. This results in the phosphate head being hydrophilic and the hydrocarbon tail being hydrophobic. This amphipathic nature of the phospholipid molecule is especially important in forming the phospholipid bilayer of the cell membrane. In an aqueous system, the polar heads of lipids align towards the polar, aqueous environment, while the hydrophobic tails minimize their contact with water and tend to cluster together. In other words the hydrophilic regions face the exterior and interior of the cell whereas the hydrophobic hydrocarbon tails associate together to form the interior of the cell membrane. The formation of lipid bilayers is an energetically preferred process.

Phosphoglycerides constitute about 40 % of cell membranes, the remaining 60 % being proteins (figure 14.3). This cell membrane is impermeable to ions and charged molecules, no matter how small the size.

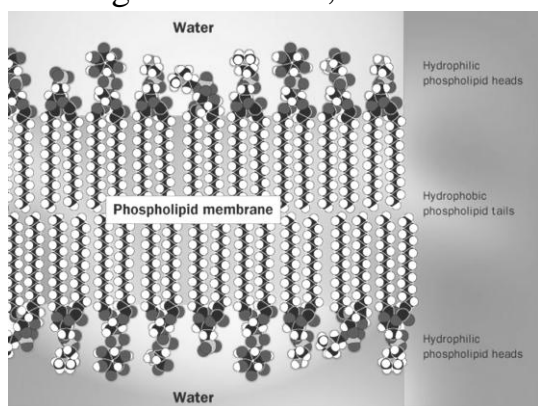
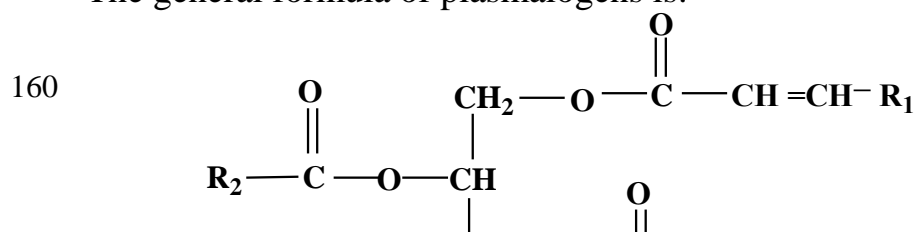

Figure 14.3 — The cell membranes of eukaryotic cells and some bacterial cells consist of three types of lipids — phospholipids, glycolipids and cholesterol molecules

Phospholipids are amphipathic; they contain both polar regions (phosphate and alcohol group) and nonpolar regions (fatty acids).

Plasmalogens make up another family of glycerol-based phospholipids. They are a type of ether phospholipids characterized by the presence of a vinyl ether linkage at the C-1 position and an ester linkage at the C-2 position. In mammals, the C-1 position is typically derived from fatty alcohols that contain from nine to eighteen carbon atoms, while the C-2 position is most commonly occupied by polyunsaturated fatty acids. The most common head groups present in mammalian plasmalogens are ethanolamine (designated plasmenylethalamines) or choline (designated plasmenylcholines).

The general formula of plasmalogens is:



Plasmalogens are found in numerous human tissues, with particular enrichment in the nervous, immune, and cardiovascular system. In human heart tissue, nearly 30–40% of choline glycerophospholipids are plasmalogens. Even more striking is the fact that almost 30% of the glycerophospholipids in the adult human brain and up to 70% of myelin sheath ethanolamine glycerophospholipids are plasmalogens.

Sphingolipids are sphingosine derivatives. In sphingolipids, a single fatty acid is attached to the nitrogen of the sphingosine via an amide bond while the phosphate group is attached onto the primary alcohol via an ester bond. The phosphate group can also be modified. For instance, in sphingomyelin, the phosphate group is modified with a choline molecule.

Examples of sphingolipids are **ceramides** —acyl derivatives of sphingosine, in which the amino group is acylated with a fatty acid. They are accumulated in brain and nerve tissues:

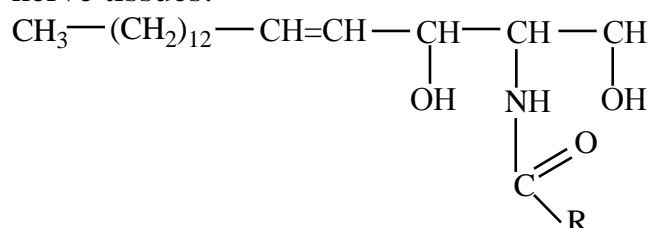

The **sphingomyelins** are phosphate diesters of sphingosine, in which molecules amino group is acylated by fatty acids:

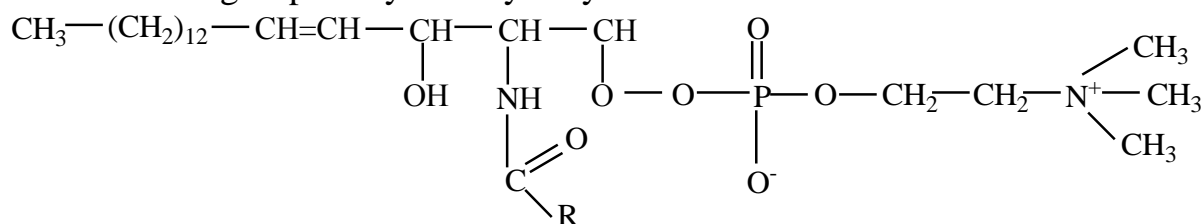

Glycolipids include carbohydrate residues, often D-galactose, and do not contain phosphoric acid and related amino alcohols. **Cerebrosides**, which are important components in animal muscle and nerve cell membranes, are the bright example of glycolipids. The sugar residue in their molecules can be either glucose or galactose; the two major types are therefore called glucocerebrosides and galactocerebrosides. Galactocerebrosides are typically found in neural tissue, while glucocerebrosides are found in other tissues. They contain D-glucose or D-galactose sugar units:

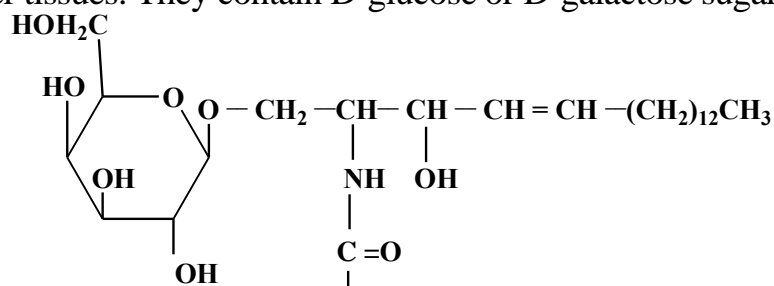

14.4. Chemical Properties of Saponifiable Lipids

Three types of chemical reactions are typical for all saponifiable lipids: hydrolysis, oxidation and addition.

Hydrolysis of lipids occurs in acidic and basic media.

Base catalyzed hydrolysis (saponification) is irreversible and gives glycerol and a mixture of fatty acids' salts:

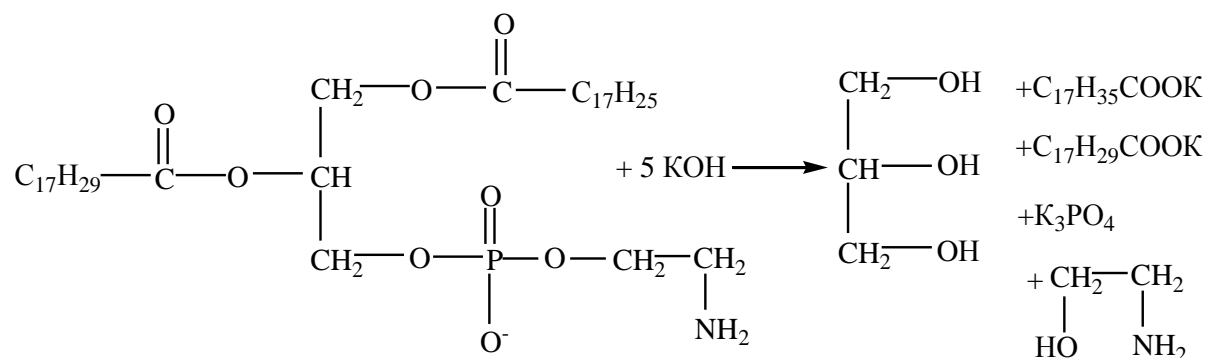

Soaps are Na- and K- salts of saturated fatty acids. Na-salts are solid soaps while K-salts are liquid soaps. The conversion of animal fats into soap by heating with alkaline is one of the oldest of chemical process. Soap has been produced for at least 2300 years, having been known to the ancient Celts and Romans. In the 16 and 17 centuries soap was rather rare substance, used mainly in medicine. In the 19 century the German organic chemist J. von Liebig was led to remark that the quantity of soap consumed by a nation was an accurate measure of its wealth and civilization. At present annual world production of soap is well over 6 million tons.

Acid catalyzed hydrolysis is reversible and gives a mixture of fatty acids and glycerol:

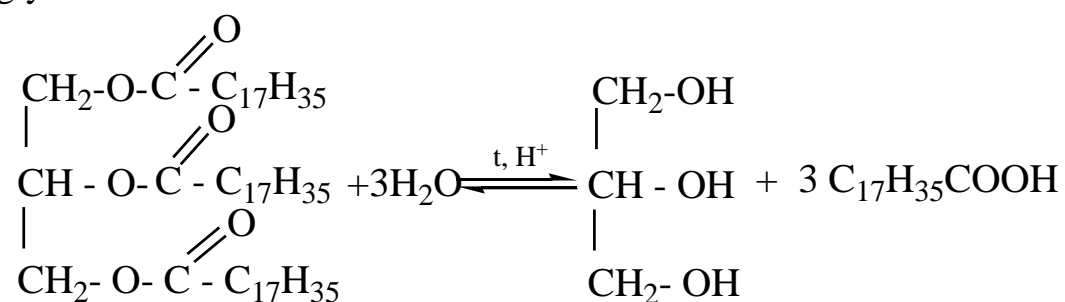

A similar process takes place in the gastrointestinal tract of humans when lipids are hydrolyzed by the enzyme lipases to yield fatty acids and glycerol.

Addition. Lipids undergo addition reactions to double bonds of unsaturated acids' radicals. The most important reaction of this type is hydrogenation of vegetable oils. By hydrogenation vegetable oils are converted into solid fats:

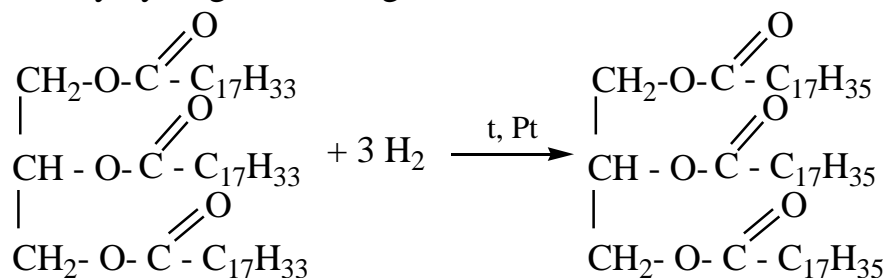

Margarine is made by hydrogenating cotton seed, soybean or corn oil. The product may be churned with milk and artificially colored to mimic butter's flavor and appearance.

The oxidative processes involving lipids are quite diverse. For example, oxidation of unsaturated triacylglycerols by atmospheric oxygen is accompanied by their hydrolysis and is a portion of the process known as rancidity (dairy product gain bitter taste):

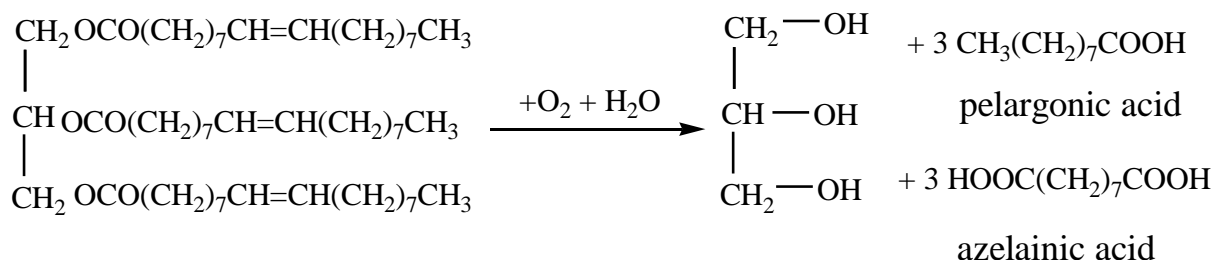

Unsaturated fatty acids and lipids that contain radicals of unsaturated acids are easily oxidized by potassium permanganate water solutions into glycols:

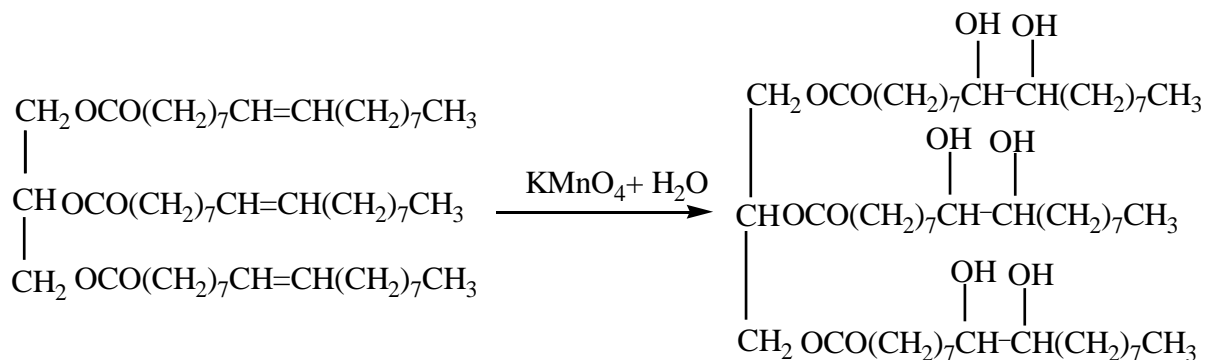

When the reaction is running we observe how pink KMnO_4 solution turns colorless.

Lipid peroxidation refers to the oxidative degradation of lipids. It is the process in which free radicals "steal" electrons from the lipids in cell membranes, resulting in cell damage. This process proceeds by a free radical chain reaction mechanism. It most often affects polyunsaturated fatty acids, because they contain multiple double bonds in between which lie methylene bridges (-CH₂-) that possess especially reactive hydrogens. The scheme of lipid peroxidation is represented in figure 14.4.

Initiation is the step in which a fatty acid radical is produced. The most notable initiators in living cells are reactive oxygen species such as OH[•] and HO₂[•], which combines with a hydrogen atom to make water and a fatty acid radical.

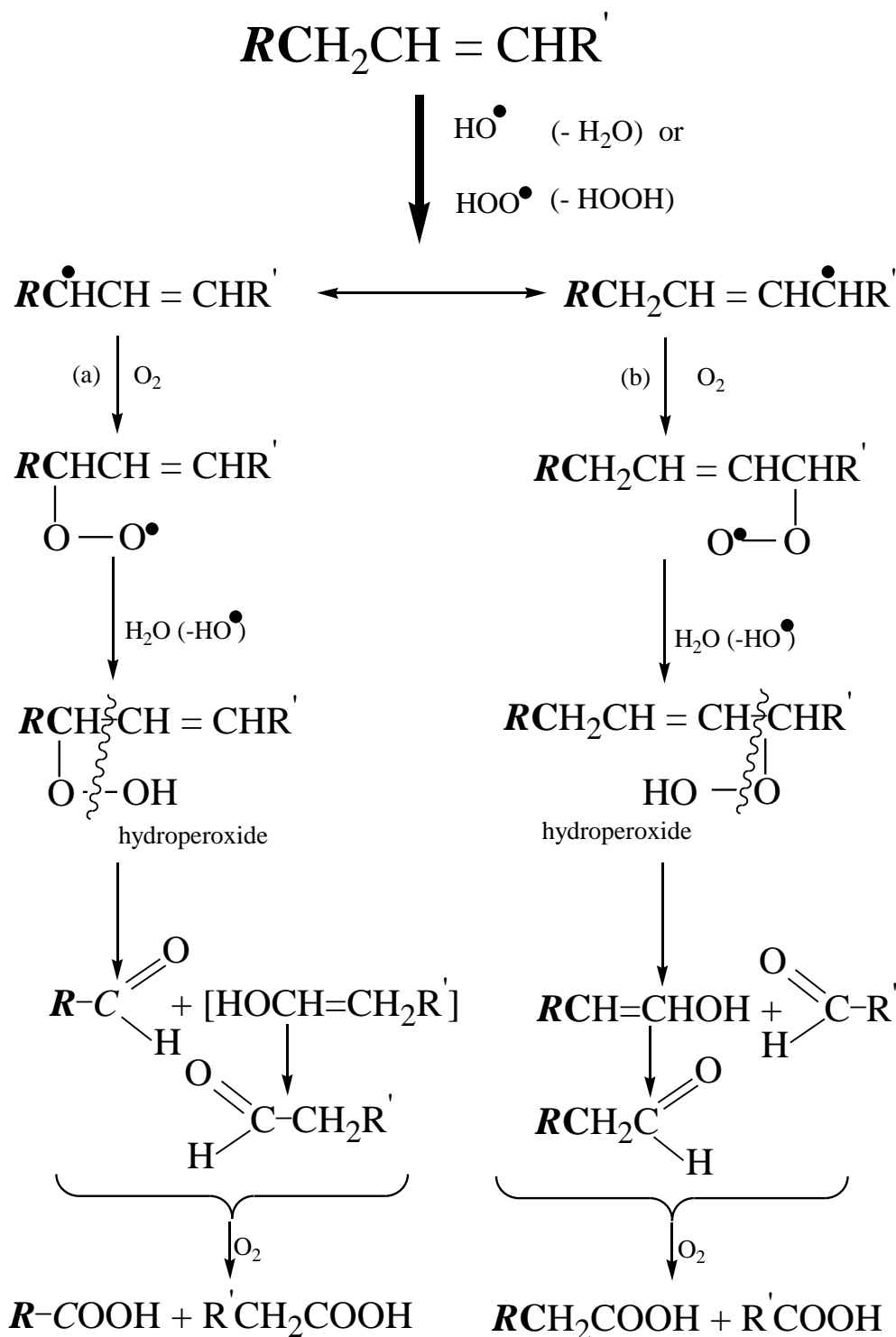

Figure 14.4 — Scheme of peroxidation

The fatty acid radical is not a very stable molecule, so it reacts readily with molecular oxygen, thereby creating a peroxy-fatty acid radical. This radical is also an unstable species that reacts with another free fatty acid, producing a different fatty acid radical and lipid peroxide. Lipid peroxides are unstable and at a room temperature are decomposed into aldehydes that undergo further oxidation into carboxylic acids.

Living organisms have different molecules that speed up termination by catching free radicals and, therefore, protecting the cell membrane. One important such antioxidant is vitamin E. Other antioxidants made within the body include the enzymes superoxide dismutase, catalase, and peroxidase.

14.5. Laboratory Work

LIPIDS

Test 1. Solubility of fats and oils

Pour 5 drops of a vegetable oil into 6 test tubes and try to dissolve it in 1 ml of a solvent. Solvents are the following: water – in the first test tube, ethyl alcohol – in the second test tube, ethyl ether – in the third test tube, hexane – in the fifth test tube and benzene – in the sixth test tube. Compare solubility of vegetable oil in different solvents. Make a conclusion about fats and oils solubility.

Test 2. Emulsion of fats and oils

Pour 5 ml of distilled water into four test tubes and add 10 drops of vegetable oil into each of them. Treat a mixture in the first test tube with 5 drops of 1% sodium hydroxide solution. Treat a mixture in the second test tube with 2 - 5 drops of soap solution. Treat a mixture in the third test tube with 3 - 5 drops of soda solution. A mixture in the fourth test tube is given for comparison.

Compare stability of prepared emulsions. What substances are the best emulgators?

Test 3. Preparing of saturated fatty acids

Treat 5 ml of soap solution with 1-2 ml of hydrochloric acid (1:1). Strong acids display saturated fatty acids from their salts. What can you see?

Write an equation for a chemical reaction when sodium stearate is treated with hydrochloric acid.

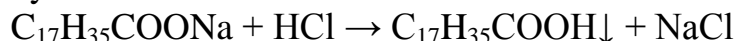

Test 4. Test on unsaturated fatty acids

Pour 1-2 ml of vegetable oil into a test tube and dissolve it in 2-3 ml of hexane. You may use diethyl ether or chloroform as well. Treat a prepared solution with 1-2 drops of bromine water and stir a mixture.

What can you see? Write the equation for a given reaction.

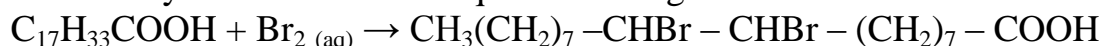

Test 5. Elaidinic test

Pour 1 ml of vegetable oil into a test tube and treat it with 10-15 drops of 20 % nitric acid and 1-2 ml of 10 % NaNO_3 solution. Mix the prepared mixture by a glass stick. Observe how under the effect of nitrogen oxides liquid oleic acid (cis-isomer) isomerises into solid elaidic acid (trans-isomer).

14.6. Exercises for the Self-Control

1. Write the structure for the following lipids:

- glyceryl triolinolate. Solid or liquid is it?
- lecithin with the radicals of the palmitic and arachidonic acids;
- phosphatidylserine with the radicals of the oleic and steric acids;
- cephalin with the radical of the palmitic acids;
- plasmalogen with the radicals of the calamine, oleic acid;
- sphingomyelin with the radical of arachidonic acid;
- ceramide with the radical of linolenic acid.

2. Write for the saponification, hydration, and acid catalyzed hydrolysis of glyceryl trilinolenate. Name the products.

3. Write the formulas and explain the iodine number for the following lipids:

- glyceryl tributyrate;
- glyceryl trioleate.

4. Write the equations of liquid soap synthesis using:

- glyceryl tripalmitate;
- glyceryl disteroatepalmitate.

5. Complete the equation for each of the following reactions:

- $\text{C}_{15}\text{H}_{31}\text{COONa} + \text{HCl} \longrightarrow$
- $\text{C}_{15}\text{H}_{31}\text{COONa} + \text{Mg}^{2+} \longrightarrow$

6. Write the equations for the following chemical reactions:

- acid catalyzed hydrolysis for glyceryl tripalmitate;
- saponification for lecithin with the radicals stearic and linolenic acids;

c) saponification for phosphatidylserine with the radicals of the linoleic and steric acids.

7. Illustrate with structural formulas the primary difference between a fat or oil, and a wax. Write an equation for the saponification of mericyl palmitate, the principal component of a bee wax.

CHAPTER 15 NONSAPONIFIABLE LIPIDS

After reading this chapter, you should be able to:

- define terpenes and give their examples;
- describe the chemical structure of steran and name the main classes of steroids;
- discuss chemical structure of cholesterol, its biological functions and the origin of atherosclerosis;
- outline structure and biological functions of bile acids;
- consider structure and biological functions of steroid hormones.

15.1. Terpenes

Steroids and terpenes are nonsaponifiable lipids, contained in plants (terpenes) and animals (steroids). Terpenes are volatile constituents of plant resins and essential oils. They were originally named after turpentine, the volatile oil from pine trees used in oil painting. From the point of view of structural chemistry, terpenes are aliphatic compounds with a scattering of double bonds and rings, few functional groups, and an abundance of methyl groups.

Terpenes are compounds containing multiples of isoprene unit:

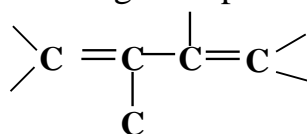

Their molecules are built by joining together 2-, 3-, or 4-isoprene skeletons end to end. They are synthesized in the plant from acetate by way of an important biochemical intermediate, isopentenyl pyrophosphate:

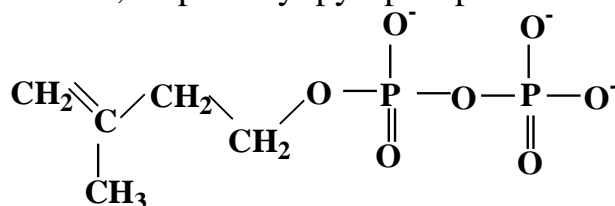

Most terpene structures can be broken down into multiples of isoprene units. Terpenes contain various functional groups (C=C, OH, C=O) as part of their structures and may be acyclic or cyclic.

Compounds with a single isoprene unit (C₅) are rare in nature, but compounds with two such units (C₁₀), called monoterpenes, are common. The examples of some terpenes are given below.

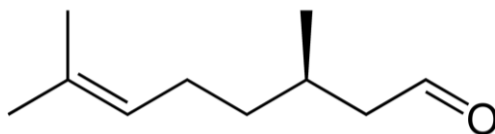

Citronellal or rhodinal or 3,7-dimethyloct-6-en-1-al (C₁₀H₁₈O) is a monoterpenoid, the main component in the mixture of terpenoid chemical compounds that give citronella oil its distinctive lemon scent.

Citronellal is a major isolate in distilled oils from the plants *Cymbopogon*, lemon-scented gum, and lemon-scented tea tree. The L-enantiomer of citronellal makes up to 80 % of the leaf oil from kaffir lime leaves and is the compound responsible for its characteristic aroma.

Citronellal has insect repellent properties, and research shows high repellent effectiveness against mosquitoes. Research shows that citronellal has strong antifungal qualities.

Limonene is a colorless liquid hydrocarbon classified as a cyclic terpene. The more common d-isomer possesses a strong smell of oranges. It is used in chemical synthesis as a precursor to carvone and as a renewables-based solvent in cleaning products. Limonene takes its name from the lemon, as the rind of the lemon, like other citrus fruits, contains considerable amounts of this compound, which contributes to their odor. Limonene is a chiral molecule, and biological sources produce one enantiomer: the principal industrial source, citrus fruit, contains D-limonene. Racemic limonene is known as dipentene. D-Limonene is obtained commercially from citrus fruits through two primary methods: centrifugal separation or steam distillation.

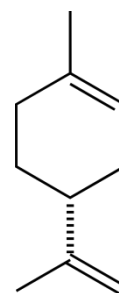

Menthol is an organic compound made synthetically or obtained from corn mint, peppermint or other mint oils. It is a waxy, crystalline substance, clear or white in color, which is solid at room temperature and melts slightly above. Menthol has local anesthetic and counterirritant qualities, and it is widely used to relieve minor throat irritation. Menthol also acts as a weak kappa opioid receptor agonist.

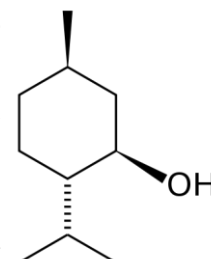

Camphor is a waxy, flammable, white or transparent solid with a strong aromatic odor. It is a terpenoid with the



chemical formula $C_{10}H_{16}O$. Camphor occurs naturally as D-enantiomer. It is found in the wood of the camphor laurel, a large evergreen tree found in Asia (particularly in Sumatra, Indonesia and Borneo) and also of the unrelated kapur tree, a tall timber tree from the same region.

Camphor can also be synthetically produced from oil of turpentine. It is used for its scent, as an ingredient in cooking (mainly in India), as an embalming fluid, for medicinal purposes, and in religious ceremonies. Camphor is readily absorbed through the skin producing either a coolness or warmth sensation by activating the ion channel TRPV3 and acts as slight local anesthetic and antimicrobial substance. There are anti-itch gels and cooling gels with camphor as the active ingredient. Camphor is an active ingredient (along with menthol) in vapor-steam products, such as Vicks VapoRub.

Camphor may also be administered orally in small quantities (50 mg) for minor heart symptoms and fatigue. Through much of the 1900s this was sold under the trade name Musterole; production ceased in the 1990s.

Citral, or 3,7-dimethyl-2,6-octadienal or lemonal, is either a pair, or a mixture of terpenoids with the molecular formula $C_{10}H_{16}O$. Citral is present in the oils of several plants, including lemon myrtle (90–98 %), lemongrass (65–85 %), lemon tea tree (70–80), lemon verbena (30–35 %), lemon ironbark (26 %), lemon balm (11 %), lime (6–9 %), lemon (2–5 %), and orange. Geranial has a strong lemon odor. Neral's lemon odor is less intense, but sweeter. Citral is therefore an aroma compound used in perfumery for its citrus effect. Citral is also used as a flavor and for fortifying lemon oil. It also has strong antimicrobial qualities, and pheromone effects in insects. Citral is used in the synthesis of vitamin A, ionone, and methyl ionone, and to mask the smell of smoke.

15.2. Steroids

Steroids are alicyclic compounds whose molecules include the skeleton of four fused rings: three six-membered and one five-membered conventionally lettered A–D. **Steroids** are tetracyclic lipids derived from the acyclic tri-terpene squalene.

Steroids constitute a major class of lipids. The common structural feature of steroid is a system of four fused rings. The A, B, and C rings are 6-membered, and the D ring is five-membered, usually all fused in a *trans* manner (figure 15.1).

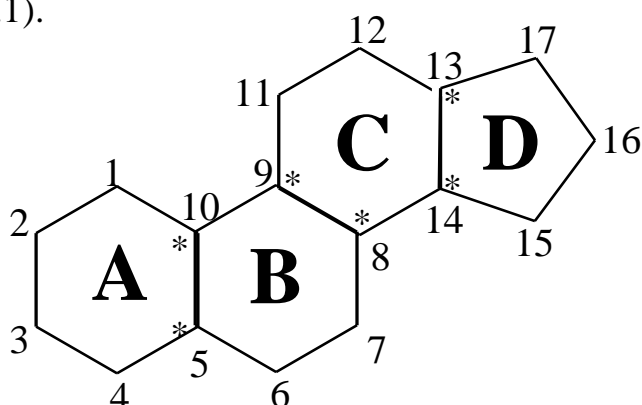
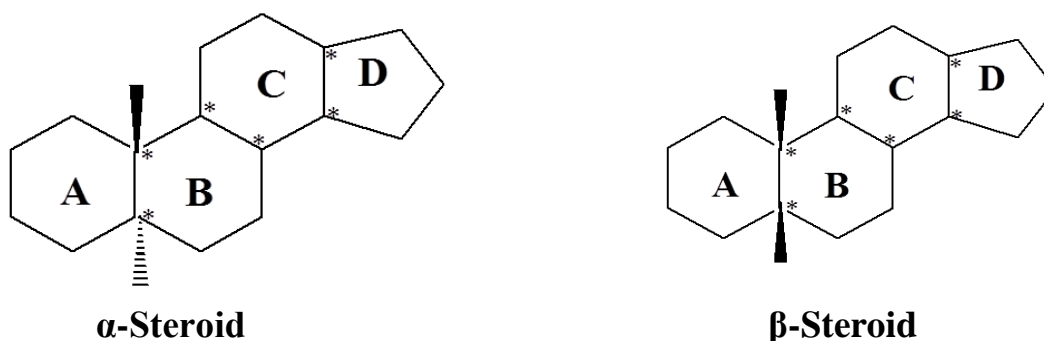

Figure 15.1 — Perhydrocyclopentanophenanthrene is the steroid ring system, showing the numbering

In most steroids, the 6-membered rings are not aromatic, although there are exceptions. Usually methyl substituents attached to C-20 and C-13 and some sort of side chain attached to C-17. Its molecule contains 6 stereogenic centers and forms 64 stereo isomers.

α - и β -Steroids can be distinguished. In α -steroids one substituent is below the plain of the nucleus and another is above it. In β -steroids they are above the plain of nucleus.



The general formula of steroids is:

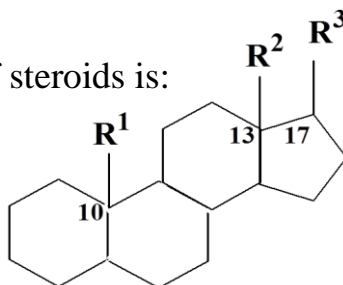

Angular radicals are located at carbons 10, 13 and 17.

Estran derivatives are estrogens — female sex hormones. Androstan derivatives are androgens — male sex hormones. Pregnan derivatives are corticosteroids. Cholan derivatives are bile acids, and cholestan derivatives are sterines table 15.1).

Table 15.1 — Angular radicals for Steroids

| Name | R^1 | R^2 | R^3 |
|-----------|------------------|------------------|-----------------------------------|
| Estran | -H | -CH ₃ | -H |
| Androstan | -CH ₃ | -CH ₃ | -H |
| Pregnan | -CH ₃ | -CH ₃ | -CH ₂ -CH ₃ |

| | | | |
|-----------|------------------|------------------|--|
| Cholestan | -CH ₃ | -CH ₃ | $\begin{array}{c} \text{---CH(CH}_2\text{)}_3\text{CH-CH}_3 \\ \qquad \\ \text{CH}_3 \qquad \text{CH}_3 \end{array}$ |
| Cholan | -CH ₃ | -CH ₃ | $\begin{array}{c} \text{---CH(CH}_2\text{)}_2\text{-CH}_3 \\ \\ \text{CH}_3 \end{array}$ |

Perhaps the best known steroid is **cholesterol**. Cholesterol (figure 15.2) is present in all animal cells but is mainly concentrated in the brain and spinal cord. Cholesterol is an unsaturated steroid alcohol, which contains 27 carbon atoms, of which 17 are incorporated into perhydrocyclo-pentanophenanthrene nucleus. Another two carbon atoms are in angular methyl groups and eight are in the peripheral side chain. It is almost completely saturated, having just one double bond between carbon atoms 5 and 6. There is a solitary hydroxyl group attached to carbon atom 3. In three dimensional terms the ring structure of cholesterol is approximately planar.

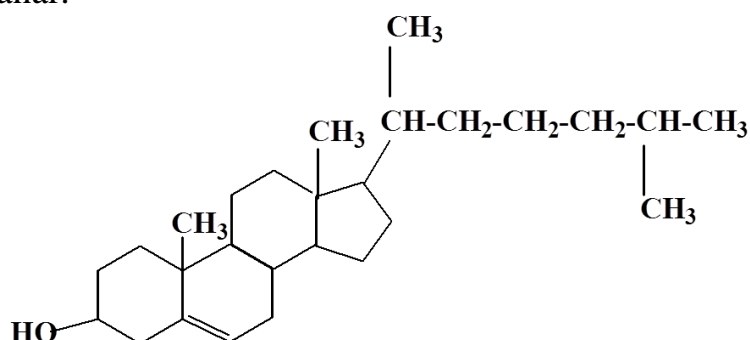

Figure 15.2 — Cholesterol

Only about 30% of circulating cholesterol occurs in the free form, the majority is esterified through the hydroxyl group to a wide range of fatty acids including oleic and linoleic acids (figure 15.3):

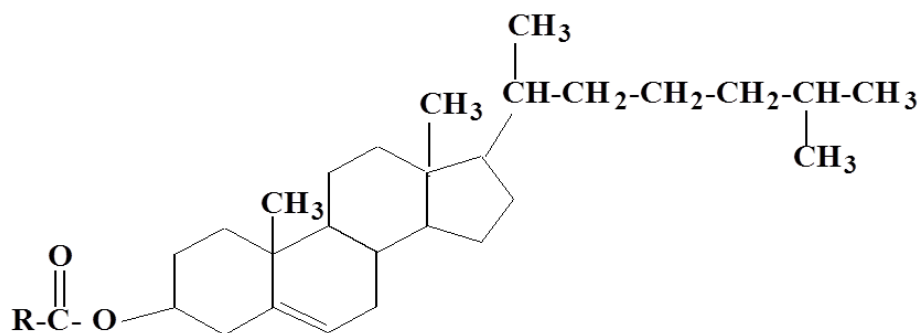

Figure 15.3 — General Formula for Cholesterol Esters

Cholesterol enters the body via the diet, but about 800 mg per day is synthesized normally in the body, chiefly in the liver, from acetate units. The typical daily diet contains approximately 500 mg of cholesterol, mainly in meat, eggs and dairy products. Under normal circumstances, 30–40 % of this is absorbed from the gut.

Cholesterol is a molecule of many functions:

- it is a lipid that is essential component of mammalian cell membranes (figure 15.4);
- it is the precursor for three important classes of biologically active compounds: the bile acids, the steroid hormones, and vitamin D.

Cholesterol metabolism is important in the etiology of cardiovascular disease, and it is a major component of gall stones, gall stones occur in up to 20% of the population of Western countries (figure 15.5).

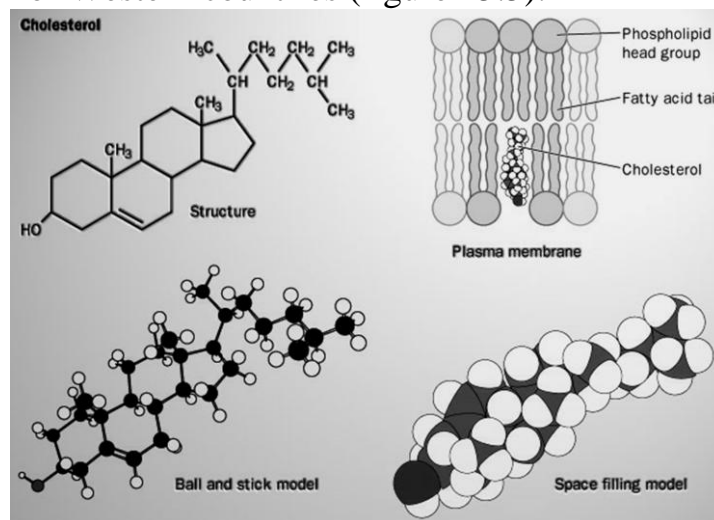

Figure 15.4 — Cholesterol is component of cell membranes



Figure 15.5 — The gall stones

If cholesterol content is high in bloodstream, the excess is deposited in arteries, making them narrow. When the coronary arteries become narrowed by chole-

terol deposits they cannot supply enough blood to the heart. The result is coronary heart diseases (CHD). This process was called **atherosclerosis** (figure 15.6).

Heart disease is the number one killer of both men and women. More than 90 million American adults, or about 50 percent, have elevated blood cholesterol levels, one of the key risk factors for heart disease. Cholesterol levels are measured in milligrams per deciliter (mg/dL). The following classification for people over age 20 was developed:

- desirable blood cholesterol is less than 200 mg/dL;
- borderline high cholesterol is between 200 and 239 mg/dL;
- high blood cholesterol is greater than 240 mg/dL.

When a patient is diagnosed with elevated blood cholesterol, doctors prescribe a program of reduced dietary saturated fat and cholesterol, together with physical activity and weight control, as the primary treatment before resorting to drug therapy.

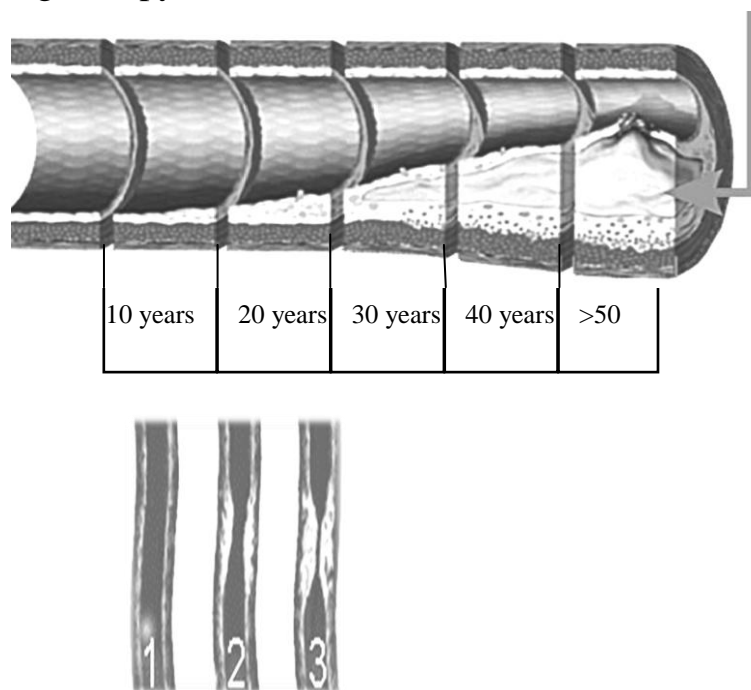

Figure 15.6 —
The stages in atherosclerosis development

Bile acids are steroid acids found predominantly in the bile of mammals. They are the most important metabolic products of cholesterol. Their biosynthesis occurs in liver and results in the four main bile acids production. Among them **cholic acid** is most abundant.

Cholic acid occurs in the bile duct, where it is present mainly in the form of various amide salts. These salts function as emulsifying agents to facilitate the absorption of fats in the intestinal tract. They are, in a sense, biological soaps. (Figure 15.7)

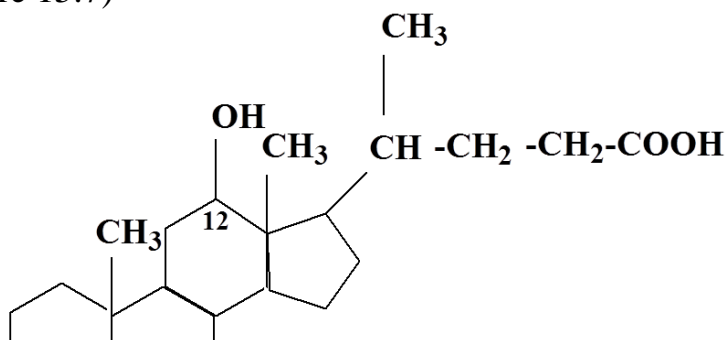

Figure 15.7 — Scheme of cholic acid

All bile acids have 24 carbon atoms with the terminal carboxyl group. They also have a saturated steroid nucleus and differ only in the number and position of the additional hydroxyl groups. All hydroxyl groups have the α -configuration (below the plain of the nucleus).

At physiologic pH, the bile acids are mainly ionized and so they occur as sodium or potassium salts. Through amide bond they are linked with glycine and taurine ($\text{H}_2\text{N}-\text{CH}_2-\text{CH}_2-\text{SO}_3\text{H}$). Bile acids and their salts are powerful surface active agents needed to aid in the digestion of lipids and in the absorption of vitamins A, D, E, and K from the intestinal tract (figure 15.8). They act as detergents assisting the emulsification of ingested lipids into very small globules; this aids the enzymatic digestion and absorption of dietary fat. In total about 20-30 grams of bile acids are secreted into the intestine daily; about 90% of excreted bile acids are reabsorbed and recycled.



Figure 15.8 — Some bile acids are applied as drugs to dissolve gall stones

Steroid hormones are bio regulators which control metabolic processes and physiological functions in vivo. There are three broad groups of steroid hormones:

- corticosteroids;
- male sex hormones (androgens);
- female sex hormones (estrogens and progestagens).

The corticosteroids are hormones excreted by adrenal cortex. They fall into two categories: glucocorticoids and mineralocorticoids. Glucocorticoids affect carbohydrate metabolism and immune functions. They are able to facilitate the metabolism of carbohydrates, fat, and protein, which increases gluconeogenesis and

helps provide fuel to the cells especially in times when the body is under stress. Loss or profound diminishment of glucocorticoid secretion leads to a state of deranged metabolism and an inability to deal with stressors which, if untreated, is fatal. Glucocorticoids are also among the most frequently used drugs, and often prescribed for their anti-inflammatory and immunosuppressive properties.

The vast majority of glucocorticoid activity in most mammals is from cortisol:

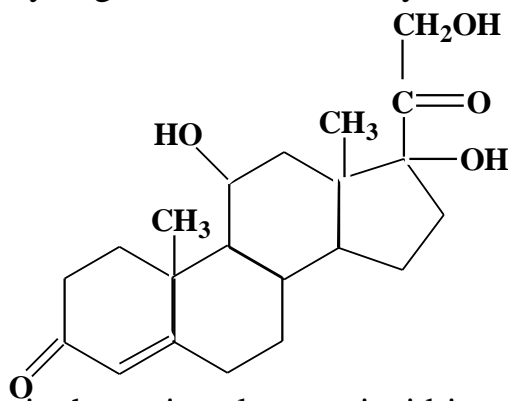

Corticosterone is the major glucocorticoid in rodents, is another important glucocorticoid:

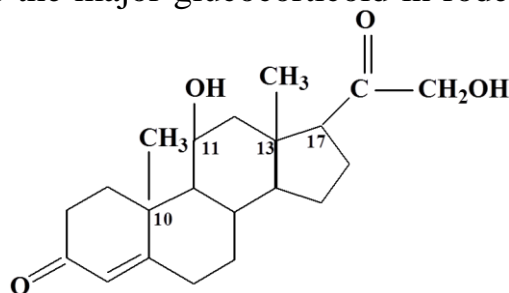

Mineralocorticoids are corticosteroids that help maintain blood volume and control renal excretion of electrolytes (figure 15.9).

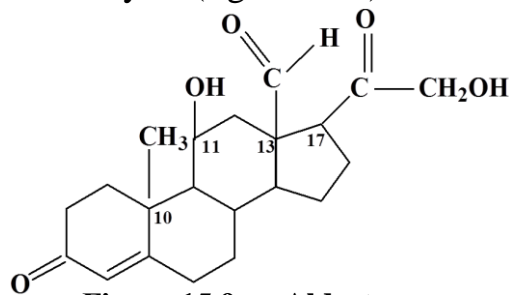

Figure 15.9 — Aldosterone

The **sex hormones** are compounds, produced in the ovaries and testes that control reproductive physiology and secondary sex characteristics. Those sex hormones that predominate in females are of two types.

The **estrogens** are essential for initiating changes during the menstrual cycle and for the development of female secondary sex characteristics. The most plentiful estrogens are **estron** and **estradiol** (figure 15.10).

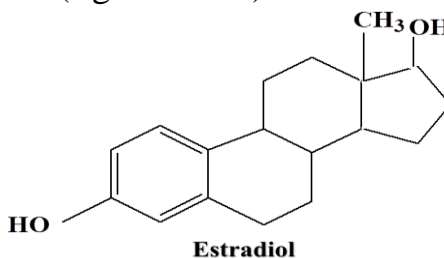
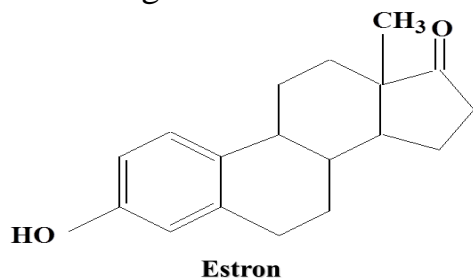

Figure 15.10 — The estrogens

Progestagens maintain a pregnancy and prevents further ovulation during that time. **Progesterone** (figure 15.11) is the most essential hormone of this group. It prepares the uterus for implantation of the fertilized egg, also maintains a pregnancy and prevents further ovulation during that time It is administered clinically to prevent abortion in difficult pregnancies.

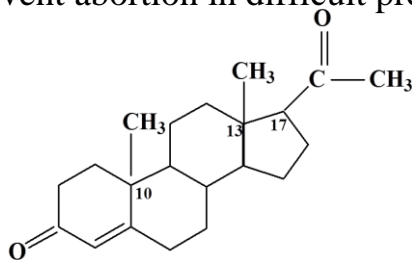
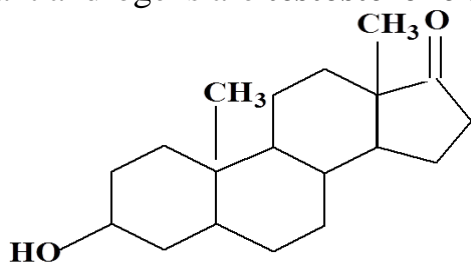
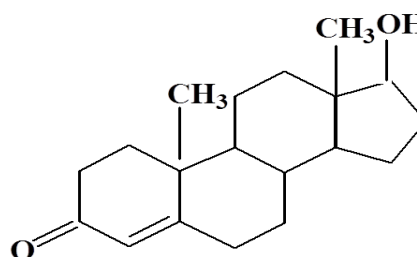

Figure15.11 — Progesterone

Sex hormones that predominate in males are called **androgens**. They regulate the development of male reproductive organs and secondary sex characteristics, such as facial and body hair, deep voice, and male musculature. Two important androgens are **testosterone** and **androsterone** (figure 15.12).



Androsterone



Testosterone

Figure 15.12 — Androgens

Testosterone is an anabolic (muscle-building) steroid. Drugs based on its structure are sometimes administered to prevent withering of muscle in people recovering from surgery, starvation, or similar trauma. Testosterone is sometimes illegally administered to athletes and race horses to increase muscle mass (figure 15.13). If taken in high doses, they can have serious side effects, including sexual malfunctions and liver tumors.



Figure 15.13 — The bodybuilders

15.3. Exercises for the Self-Control

1. Predict the products of the following reactions. (Consult the text for the structure of the starting materials)

- cholesterol and acetic anhydride;
- testosterone and LiAlH_4 ;
- cholesterol and Br_2 (CCl_4);
- androsterone and KMnO_4 .

2. Write the cholesterol molecule, and show polar and nonpolar groups in the structure of cholesterol. Explain the orientation of cholesterol in the cell membranes.

3. How many stereogenic centers are present in lanosterol?

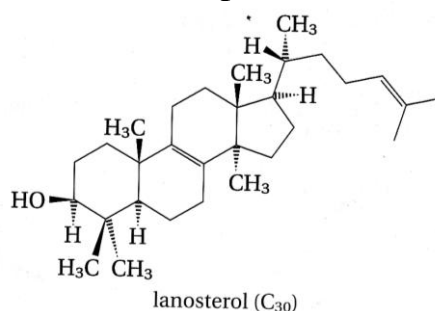

4. Write the cortisol molecule. Taking into chemical centers, explain the chemical properties of cortisol. Specify the mechanism.

5. Steroids: chemical structure, biological functions. Steran and its conformation.

6. Steroid hormones: chemical structure, biological functions.

7. Bile acids: chemical structure, biological functions.

CHAPTER 16 CARBOHYDRATES

After reading this chapter, you should be able to:

- define carbohydrates and discuss their classification.
- describe structure, isomerism and chemical properties of monosaccharides.
- discuss structure, chemical properties and biological functions of reducing and non-reducing disaccharides.
- describe structure and properties of most important homo- and heteropolysaccharides (starch, glycogen, cellulose, dextrans, chondroitin sulfate and hyaluronic acid).

16.1. Classification of the carbohydrates

Carbohydrates occur in all plants and animals and are essential to life. Through photosynthesis, plants convert atmospheric carbon dioxide to carbohydrates, mainly cellulose, starch and sugars.

The word “*Carbohydrates*” arose because molecular formulas of these compounds can be expressed as Hydrates of carbon: $C_n(H_2O)_m$.

Carbohydrates are ubiquitous in nature:

- They serve as the source energy for most living cells (1 g — 16.9 kJ).
- They are components of genetic materials RNA and DNA.
- Polysaccharides are used to provide structural strength to cells. The best example is the cell wall of plant cells, formed by the cellulose, which coats the cell and makes it rigid.
- Saccharides associated with membrane lipids or proteins (glycolipids and glycoproteins) are involved in cell-cell interactions, and immunological responses. Saccharides covalently attached to proteins determine their location or destination in the cell and the metabolic routes they are supposed to follow.

Diseases associated with disorder in carbohydrates metabolism:

- Diabetes mellitus.
- Galactosemia.
- Glycogen storage diseases.
- Lactose intolerance.

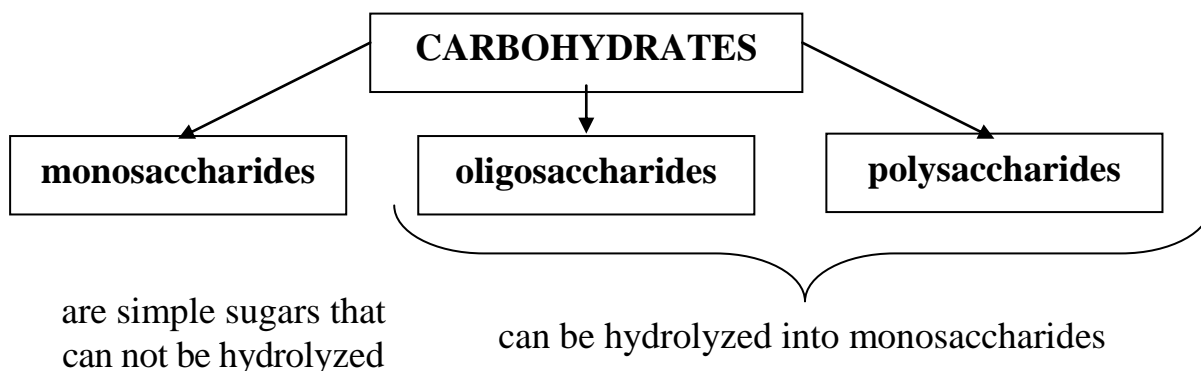

Monosaccharides are polyhydroxyl aldehydes (**aldoses**) and polyhydroxy ketones (**ketoses**). According to the number of carbon atoms present they are: triose, tetrose, pentose, hexose. In nature pentoses and hexoses are most abundance.

Oligosaccharides are condensation products of two to ten monosaccharide units. **Disaccharides** are condensation products of two monosaccharide units. (maltose, lactose, sucrose)

Polysaccharides are condensation products of more than ten monosaccharide units. They are:

- Homopolysaccharides — consist of the identical monosaccharide units (starch, cellulose).
- Heteropolysaccharides — consist of the different monosaccharide units (hyaluronic acid, chondroitin sulfate, heparin).

16.2. Monosaccharides

All monosaccharides except dihydroxyacetone contain stereogenic centre and form optical isomers. Thus aldohexoses a number of stereogenic centre is 4 hence there are $2^4 = 16$ optical isomer (8 pairs of enantiomers). D- and L-Sugars are determined by configuration of a stereogenic center farthest from the aldehyde or ketone groups. **Only d-monosaccharides are biologically active, take part in metabolism processes.**

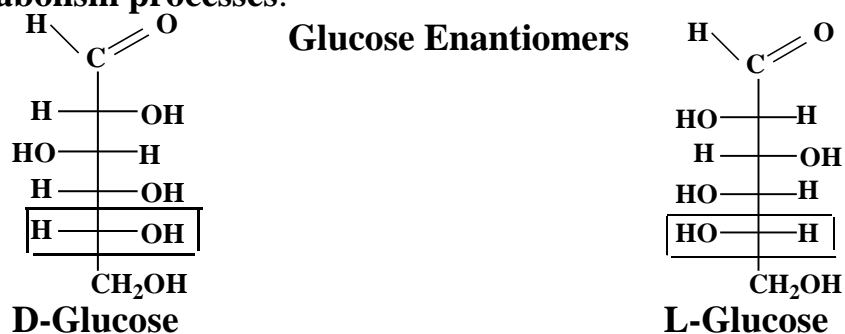

In the chemistry of carbohydrates a special name is given to diastereomers that differ in configuration at only one stereogenic centre, they are called **epimers**.

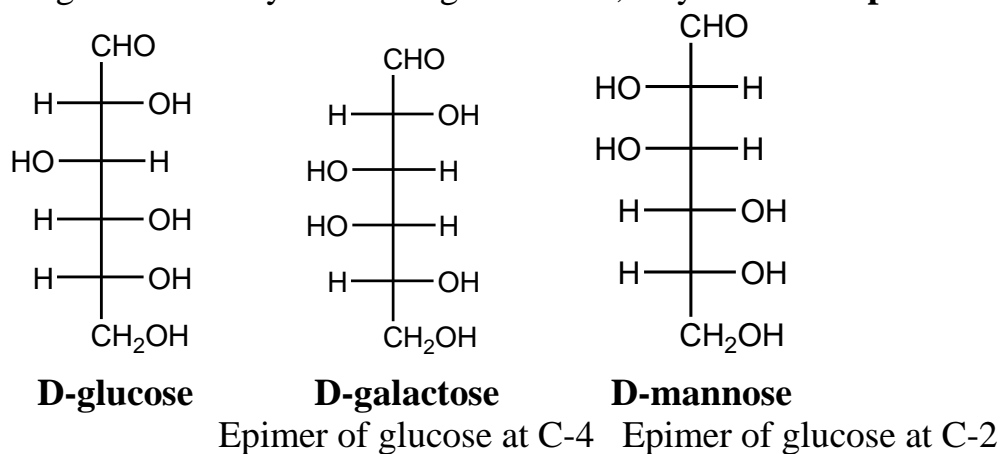

Glucose (grape sugar or blood sugar) is the most important monosaccharide. Most dietary carbohydrates are absorbed into the bloodstream as glucose, and other sugars are converted into it in liver.

Glucose is the major metabolic fuel of mammals, it is the precursor for synthesis of all the carbohydrates in a body.

Glucose content in blood is 0.08 – 0.12 %.

Cyclization of monosaccharides is result of intramolecular interaction between a hydroxyl group and a carbonyl group. **Cyclic hemiacetals and hemiketals are the products of these reactions.**

Formation of hemiacetals is a reversible process due to which an equilibrium is stated between open-chain and cyclic form of a substance in aqua solutions.

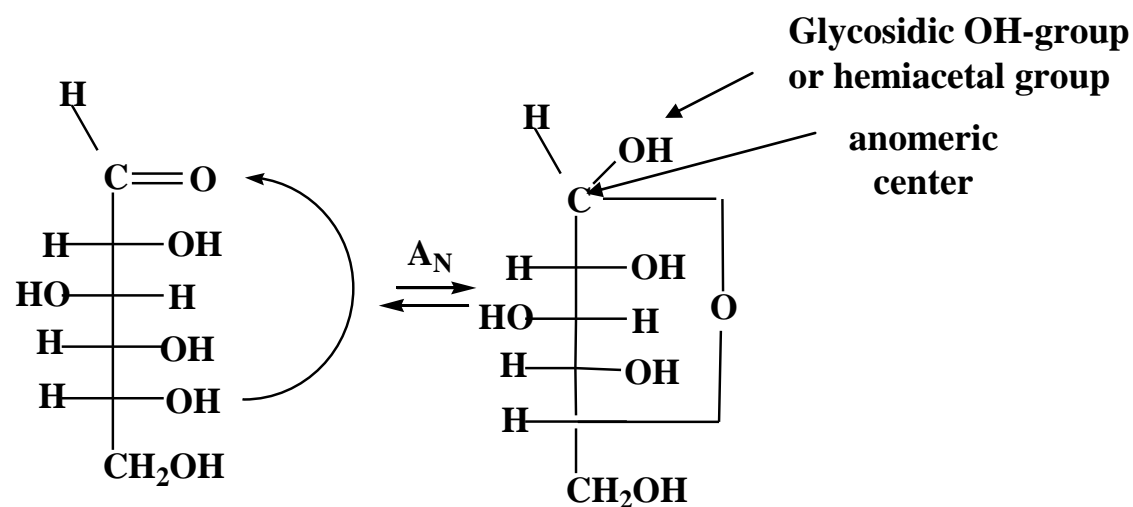

Open-chain form of D-glucose
The Fischer projection

Cyclic formula for D-glucose

Anomeric carbon is the new stereogenic center in a molecule. **Glycosidic OH-group** exhibits specific properties (not like alcohols hydroxyl groups).

Two stereo isomers that differ only in configuration at the anomeric center are **anomers (a special kind of epimers)**. Anomers are called α and β , depending on the position of glycosidic hydroxyl group:

- **α -anomer** exhibits the same configuration as the farthest stereogenic center in the Fisher projection;
- **β -anomer** exhibits the opposite configuration.

In Haworth projection the ring is represented as if it was planar with oxygen at the upper right. Hydroxyl groups on the right in the Fisher projection are down in the Haworth projection; hydroxyl groups on the left in the Fisher projection are up in the Haworth projection.

Howorth projection:

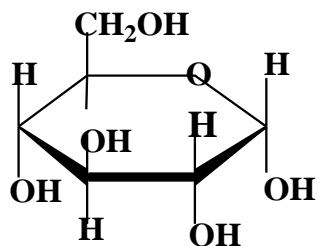

α -D glucopyranose (36 %)

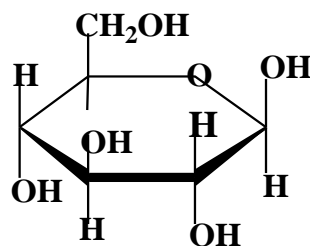

β -D- glucopyranose (64 %)

All forms of glucose are at equilibrium in water solutions. This phenomenon is defined as Cyclo-Oxo Tautomerism.

The more stable conformation for glucose is chair.

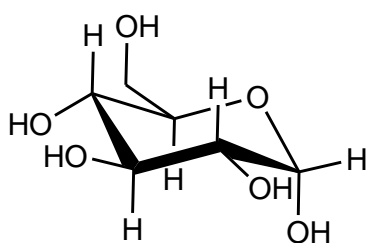

α -D glucopyranose

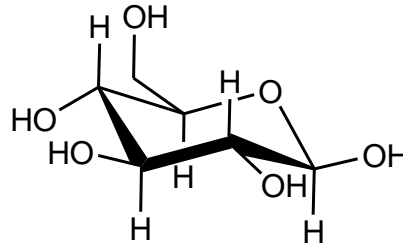

β -D-glucopyranose

β -D-Glucopyranose is more stable because all substituents are equatorial

Fructose is structural isomer of glucose. It is contained in honey and fruits. Fructose is a ketohexose and three its main forms are involved in the equilibrium in its aqueous solution.

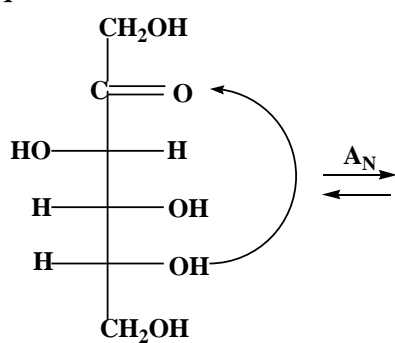

D-fructose

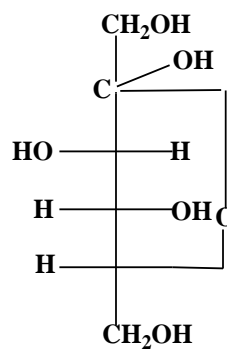

Cyclic formula for D-fructose

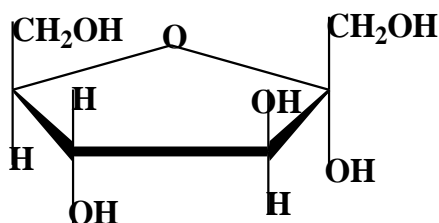

α -D fructofuranose

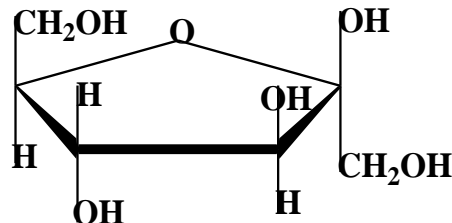

β -D- fructofuranose

Ribose and Deoxyribose are aldopentoses of nucleic acids.

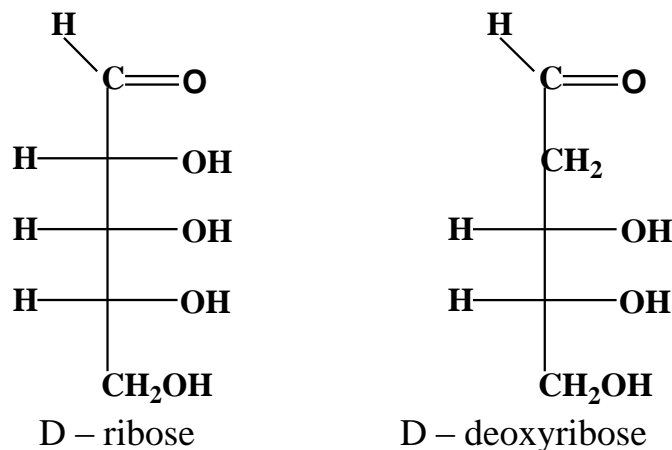

16.3. Chemical properties

Monosaccharides undergo reactions typical of alcohols and aldehydes (ketones). More over hemiacetal hydroxyl group is responsible for the specific reaction of Glycosides formation.

(a) Formation of Glycosides

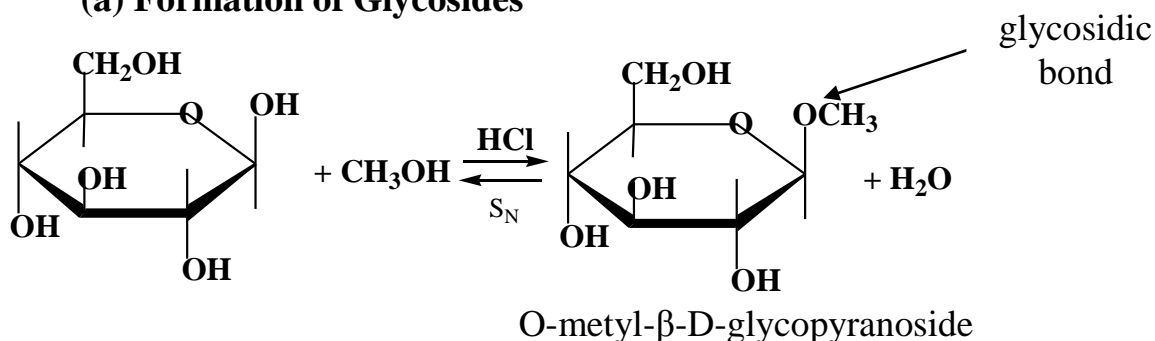

A reaction occurs in non-water medium and is catalyzed by dry HCl. A glycoside molecule is composed of two compartments:

- sugar part.
- aglicon part.

A covalent bond which links them is named glycosidic bond. This bond plays an important role in the chemistry of oligo- and polysaccharides. Glycosidic bond undergo hydrolysis in acidic medium; it is stable in basic medium

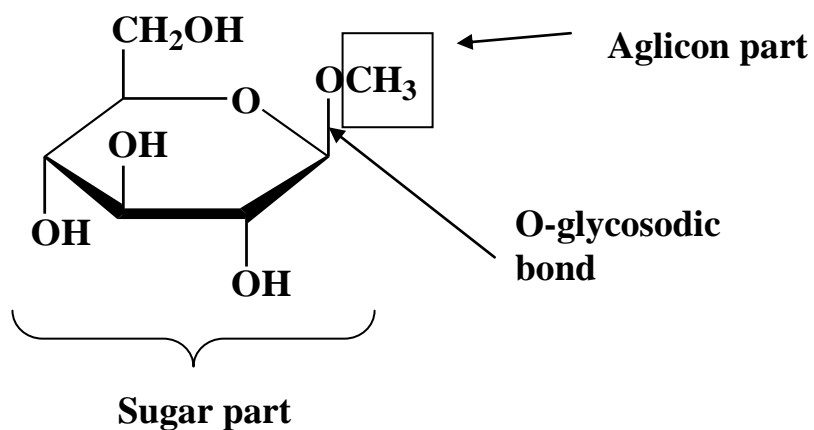

(b) the reactions typical for alcohols

Formation of ethers

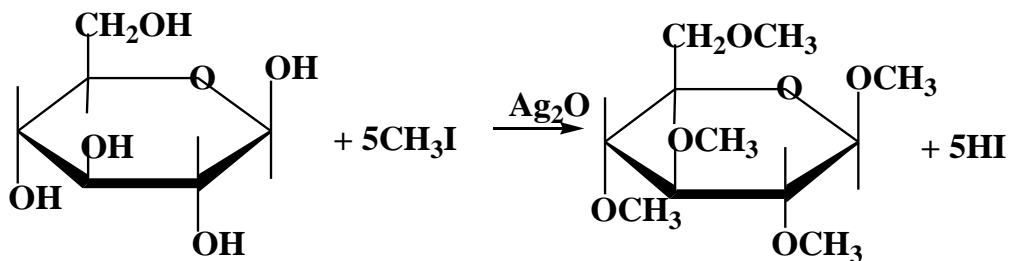

O-methyl-2,3,4,6-tetramethyl- β -D-glycopyranoside

Formation of esters

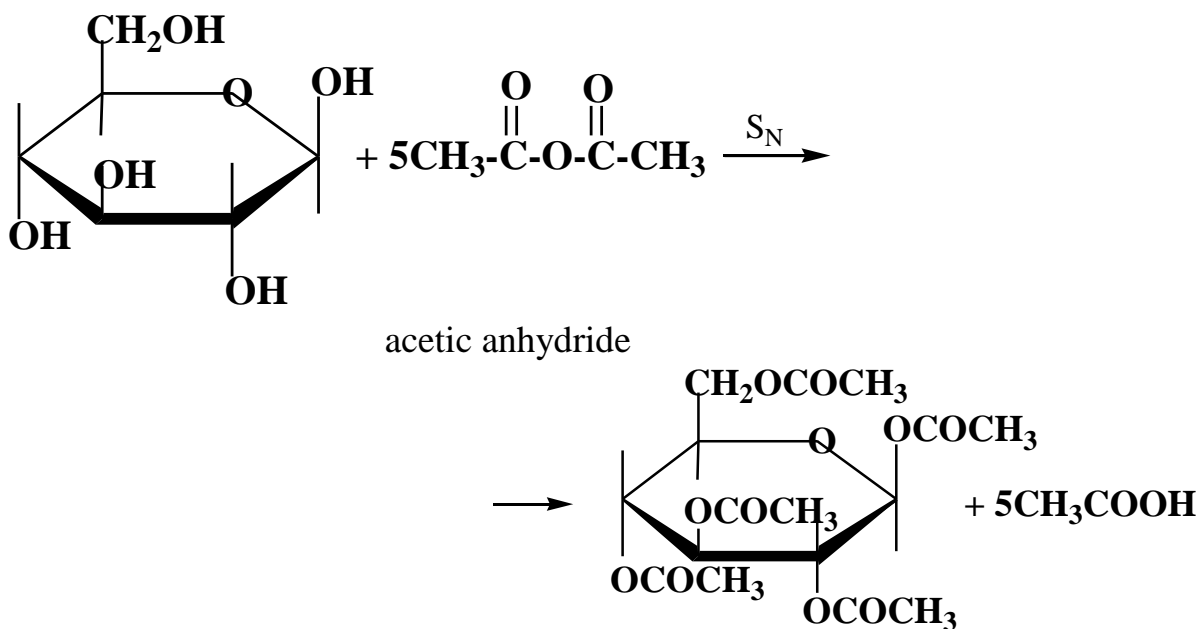

acetic anhydride

β -D-glycopyranoside pentaacetate

Phosphate esters of monosaccharides are found in all living cells; they are intermediates in carbohydrate metabolism.

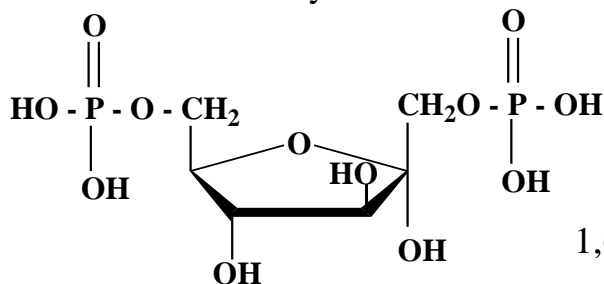

1,6-diphosphate-D-fructofuranose
(Phosphate Ester of Fructose)

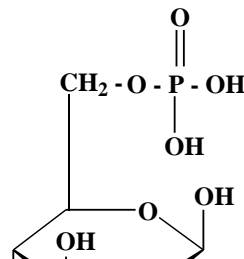

Phosphate Esters of Glucose

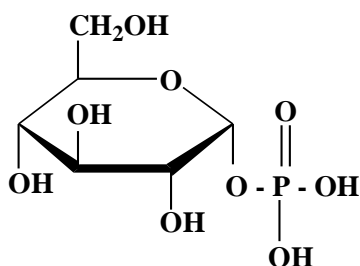

1-phosphate-D-glucopyranose

6-phosphate-D-glucopyranose

(c) the reactions typical for aldehydes and ketones

Reduction of monosaccharides

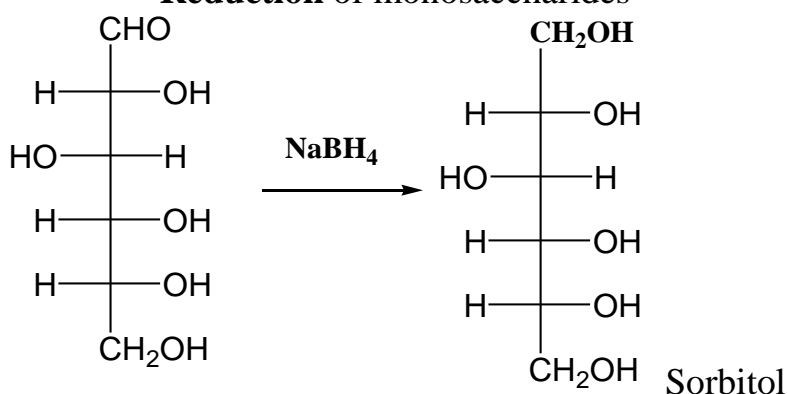

Sugar Alcohols are important in Food Industry:

- Glucose → Sorbitol.
- Mannose → Mannitol.
- Galactose → Dulcitol.
- Xylose → Xylitol.

Sorbitol is used commercially as a sweetener and sugar substitute. Mannitol occurs in olives, onions and mushrooms.

Oxidation of monosaccharides

a) The Tollen's silver mirror test:

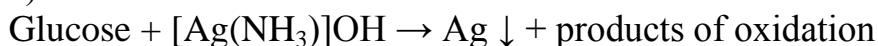

Tollen's reagent

b) The Fehling's and Benedict's tests

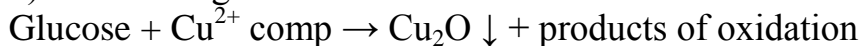

brick-red

precipitate

c) The Fehling's reagent is Cu^{2+} complexed with tartrate ion.

d) The Benedict's reagent is Cu^{2+} complexed with citrate ion.

The oxidation in neutral and acid media runs with the formation of different acids.

The oxidation of aldoses with mild oxidizing agents (Br_2 water) gives so-called aldonic acids. Strong oxidizing agents such as nitric acid attack the aldehyde group and the primary alcohol group, producing dicarboxylic acids called aldoric acids.

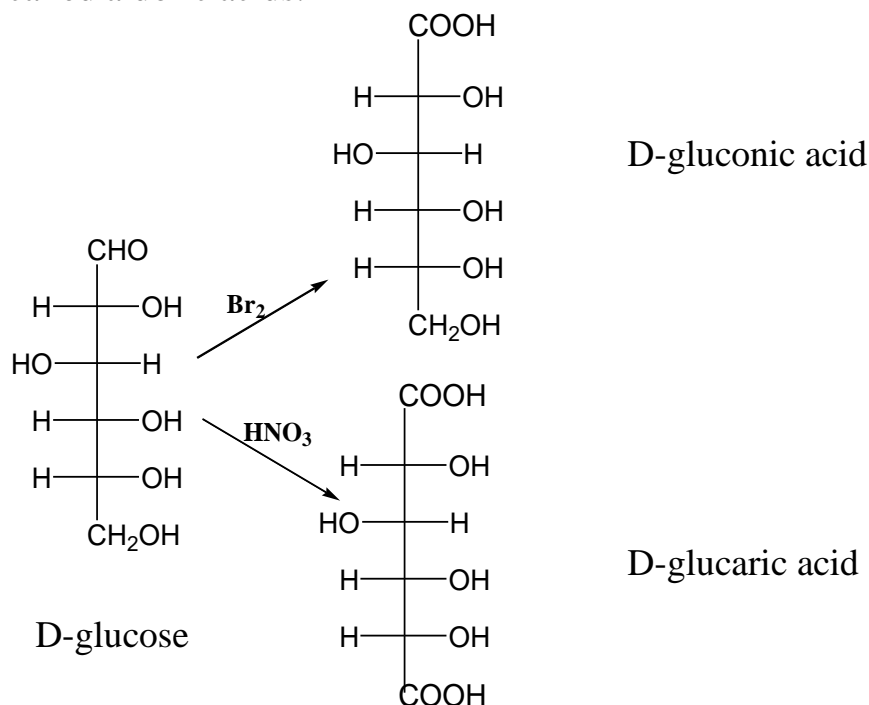

Glucuronic Acid Preparing

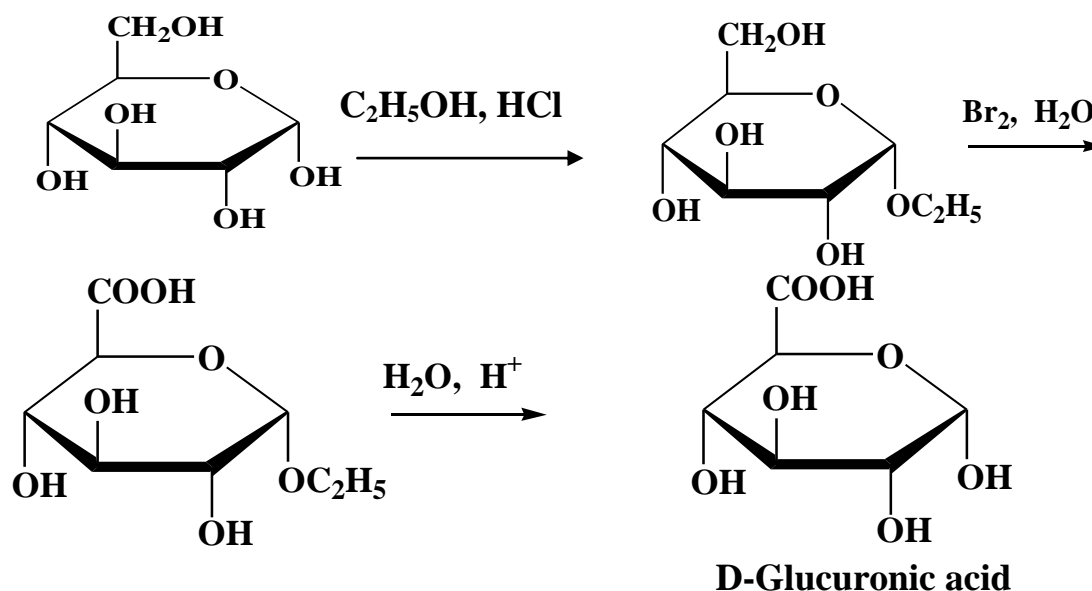

Alduronic acids are important part of detoxification pathways in animal mechanism: cells excrete water-insoluble phenols, carboxylic acids and steroids by first converting them to alduronic acids' esters or amides.

16.4. Laboratory work

MONOSACCHARIDES

Test 1: The evidence of several hydroxyl groups in the D-glucose molecule

Pour 5 drops of 2 % copper (II) sulfate solution into a test tube and treat it by 5 drops of 10 % sodium hydroxide solution. It will result in a blue copper (II) hydroxide precipitate formation. Dissolve this precipitate in glucose. Mark the color of an obtained solution. This reaction is a test on alcohols containing more than one hydroxyl groups (polyhydric alcohols). Write the equations of fulfilled reactions.

Test 2: The Tollens' silver mirror test

Pour 1 drop of 5 % silver nitrate AgNO_3 solution into a test tube and treat it by 2 drops of 10 % sodium hydroxide NaOH solution. Dissolve the prepared dark-brown precipitate in the excess of aqueous ammonia. A prepared transparent solution is used as a reagent to detect glucose and other aldoses in their solutions. It is known as the Tollens' reagent. Treat the Tollens' reagent with 2 drop of 0.5 % glucose solution and heat it in the fire of a spirit lamp. If the test tube is thoroughly clean, the silver deposits as mirror on the glass surface. Write the equations for fulfilled reactions.

Test 3: The Trommer's test (a reaction of monosaccharides with copper (II) hydroxide)

Pour 1-2 mL of glucose solution into test tube and treat it with 1 mL of 10 % sodium hydroxide NaOH solution and same drops of 1% copper (II) sulfate solution. Heat a prepared mixture up to the boiling point. What can you see? Write the equations for fulfilled reactions

Test 4: The Fehling's test (a reaction of monosaccharides with Fehling's reagent)

Pour 0.5 mL of 2 M copper (II) sulfate solution with 0.5 mL of 2 M sodium hydroxide solution. Dissolve the prepared precipitate with 3 % sodium potassium tartrate solution. A prepared solution is used as a reagent to detect monosaccharides in their solutions (the Fehling's reagent). Treat 1-2 mL of glucose solution with Fehling's reagent. Heat the mixture up to the boiling point. What can you see? Write an equation for the fulfilled reaction. Compare the results of Trommer's and Fehling's tests. What test is more useful? Why?

16.5. Exercises for the self-control

1. Write the Fischer and Haworth projection formulas for α and β anomers of D-deoxyribose, D-galactose. Configuration of what stereogenic center determines D- or L-optical family of a monosaccharide? What optical phenomenon proves cyclo-oxo tautomerism of monosaccharides?

2. Draw the Haworth projection for:

- a) β -D-fructofuranose;
- b) α -D-ribofuranose;
- c) α -D-galactopyranose;
- d) β -D-mannopyranose.

3. What chemical property of glucose lies at the bottom of its reaction with Fehling's reagent? Write the scheme of this reaction.

4. Write an equation for the reaction of α -D-galactopyranose (Haworth projection) with methyl alcohol. Under what conditions does it occur? Name a product.

5. Write an equation for the reaction of D-glucose with:

- a) bromine water,;
- b) nitric acid.

Name the prepared acids. What chemical property of glucose lies at the bottom of these reactions?

16.6. Classification Oligo- and Polysaccharides

Oligosaccharides are condensation products of two to ten monosaccharide units.

Polysaccharides are condensation products of more than ten monosaccharide units. They are:

- Homopolysaccharides — consist of the identical monosaccharide units (starch, cellulose). Those which contain only glucose units are named glucosans or glucans.
- Heteropolysaccharides — consist of the different monosaccharide units (hyaluronic acid, chondroitin sulfate, heparin)

16.7. Disaccharides

Disaccharides are condensation products of two monosaccharide units (maltose, lactose, sucrose).

Disaccharides fall into two categories:

- Reducing (maltose, lactose, cellobiose).
- Nonreducing (sucrose).

In Reducing Disaccharides formation of a glycosidic bond between monosaccharide units involves a glycosidic OH-group in the first molecule and an alcohol OH-group in the second molecule.

Glycosidic OH-group in the second monosaccharide unit is responsible for Cyclo-Oxo Tautomerism of a reducing disaccharide.

They may be classified as reducing and nonreducing sugars. The reducing sugars contain hemiacetal groups in their molecules and exhibit reducing properties; their solutions mutarotate. Nonreducing sugars do not contain hemiacetal groups; their solutions do not mutarotate.

Maltose or malt sugar is the reducing disaccharide. It does not occur widely in nature and is obtained by partial hydrolysis of starch.

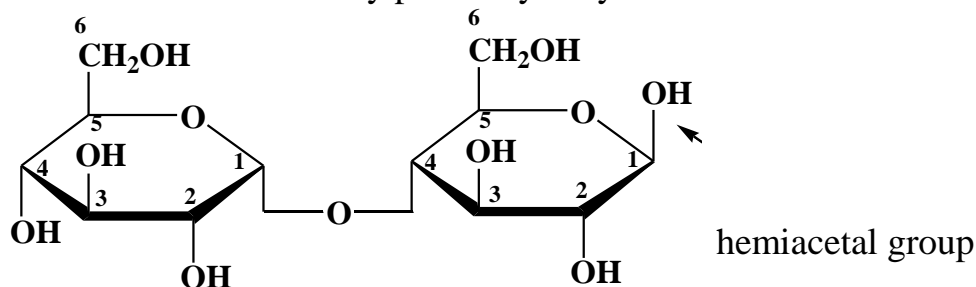

α -D-glucopyranosyl-(1 \rightarrow 4)- β -D-glucopyranose

Maltose solutions mutarotate:

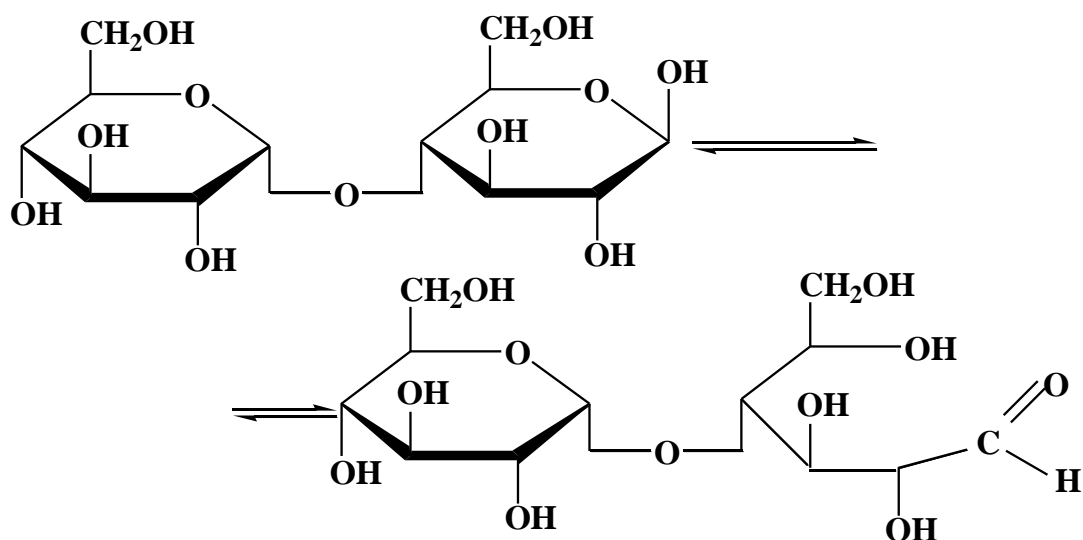

Lactose is the reducing disaccharide. It is the major sugar in human and cow's milk (4-8%). It plays an essential role in forming nonpathogenic micro flora in digestive tract of infants

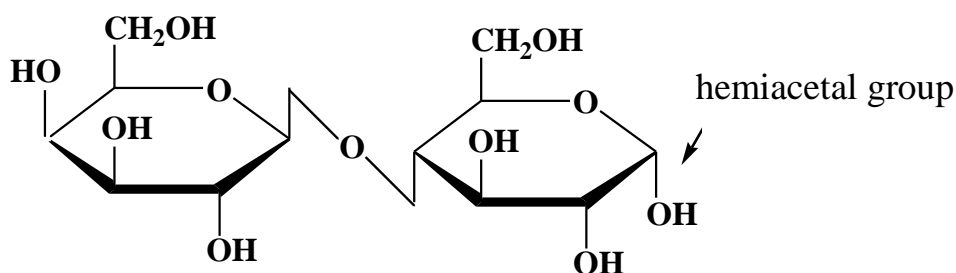

β -D-galactopyranosyl-(1 \rightarrow 4)- α -D-glucopyranose

Some human infants are born with a disease called galactosemia. They lack the enzyme that isomerizes galactose to glucose and cannot digest milk.

If galactosemia is left untreated, galactose will accumulate in the blood and body tissues and will cause damage. A newborn with untreated galactosemia may develop vomiting and diarrhea and fail to gain weight. The build-up of galactose can eventually lead to jaundice, an enlarged liver, cataracts, mental retardation, and possible death. To treat galactosemia all sources of galactose and lactose must be eliminated from the diet. That primarily means that all dairy products must be strictly avoided.

Cellobiose is a product of cellulose hydrolysis

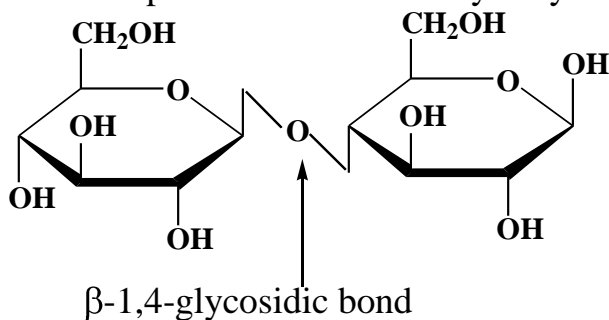

β-D-Glucopyranosyl-(1→4)-β-D-Glucopyranose

Sucrose is the nonreducing disaccharide. It occurs in all photosynthetic plants where it functions as an energy source. Its solutions do not mutarotate. Sucrose is obtained commercially from sugar cane and sugar beets, in which it constitutes 14–20 % of the plant juices. More than 100 million tons of table sugar are produced annually worldwide.

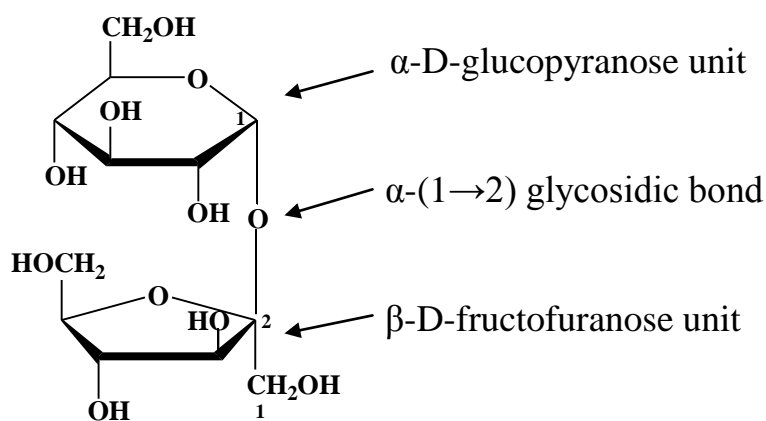

α-D-glucopyranosyl-(1→2)-β-D-fructofuranoside

16.8. Chemical properties of disaccharides

They undergo hydrolysis in acidic medium.

Glycosidic bond can be hydrolyzed in acidic media with the formation of monosaccharides.

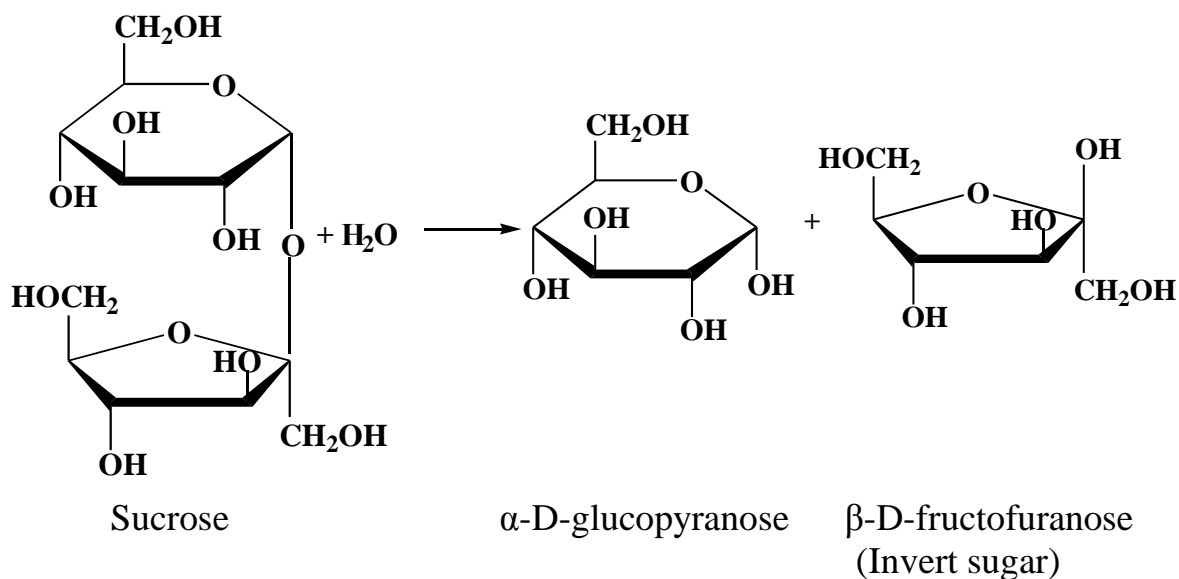

Invert sugar is a component of honey. Sucrose hydrolysis is followed by an optical effect. The initial specific rotation in its solution is $+66^\circ$, but when sucrose is hydrolyzed it becomes -20° .

Reducing disaccharides can be oxidized by different oxidizing agents; they give positive Tollens', Fehling' and Benedict's tests.

Nonreducing disaccharides cannot be oxidized by different oxidizing agents; they give negative Tollens', Fehling' and Benedict's tests.

16.9. Homopolysaccharides

Starch is the energy-storing carbohydrate of plants. It is a major component of cereals, potatoes, corn and rice. It is the form in which glucose is stored by plants for later use. Starch can be separated by various techniques into two fractions: amylose (10–20 %) and amylopectin (80–90 %). Its macromolecules are built from α -glucose which are linked by α (1–4) and α (1–6) glycosidic bonds.

Amylose's structure. Its unbranched molecules are coiled in helix.

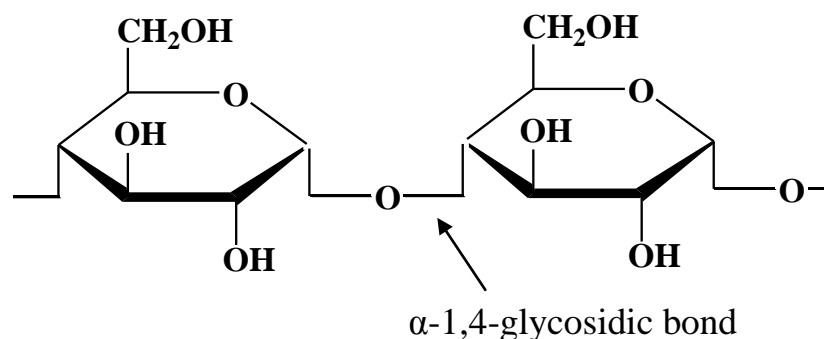

Iodine molecules (I_2) penetrate inside the helix, forming starch-iodine complex colored in intensive purple colour. This unique test can detect extremely minute traces of starch.

Amylopectin's structure. Its molecules are highly branched. Glycogen is the storage polysaccharide in animals, which is a structural analog of amylopectin, but is more highly branched (with the branch every 8 to 12 glucose units).

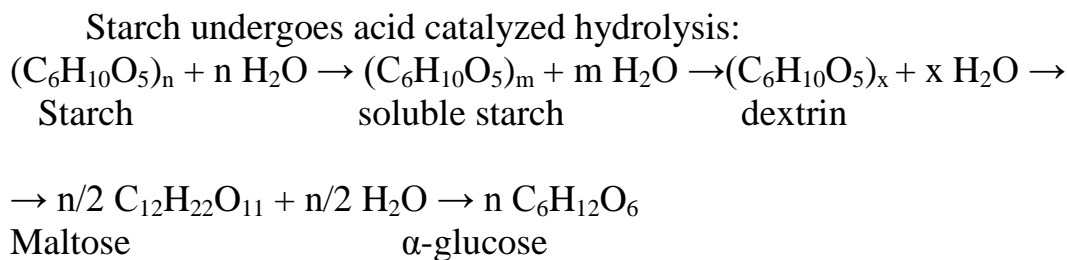
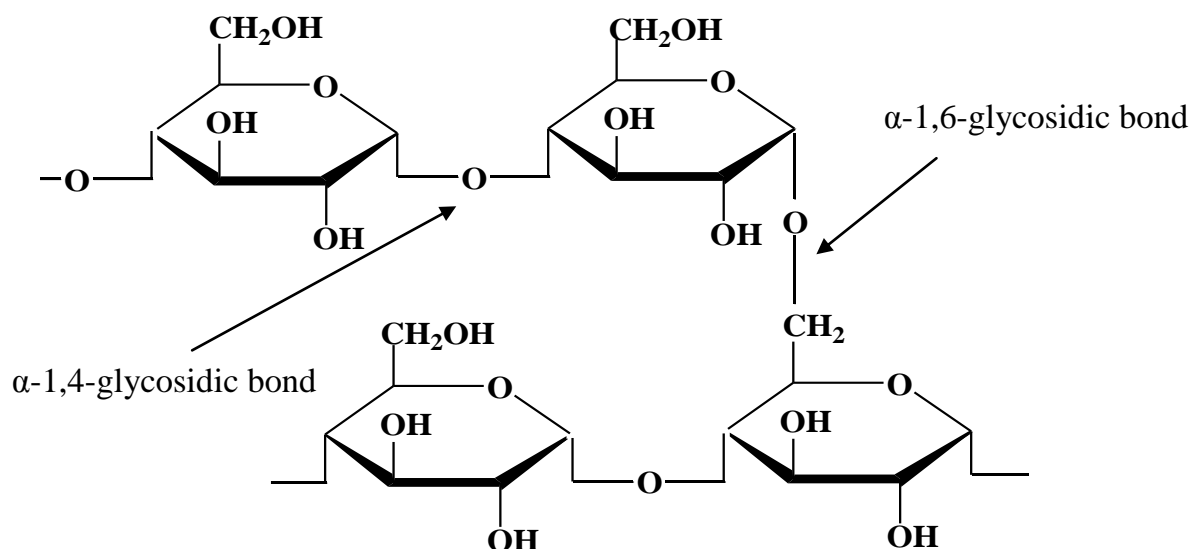

Glycogen is the storage polysaccharide in animals. The structure of glycogen is similar to that of amylopectin, although the branches in glycogen tend to be shorter and more frequent.

Cellulose is the most abundant homopolysaccharide. It is the chief constituent of the framework of plants. It is formed from β -glucose linked by β (1-4) glycosidic bonds.

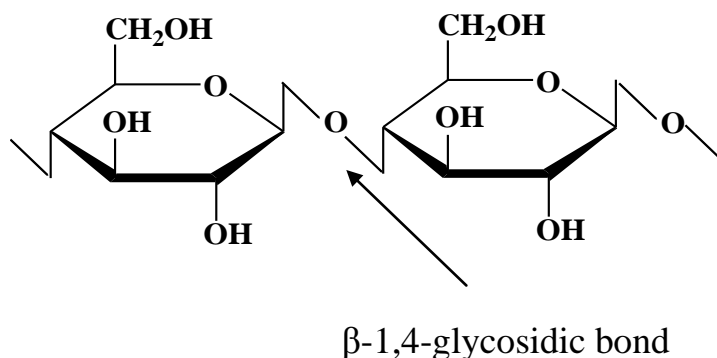

Over half of the total organic carbon in the earth's biosphere is in cellulose. Cotton fibers are essentially pure cellulose, the wood of bushes and trees is

about 50 % cellulose. The glucose units in cellulose are linked in a linear fashion. The β -glycosidic bonds permit these chains to stretch out, and this conformation is stabilized by intramolecular hydrogen bonds.

Cellulose cannot be digested by mammals because they lack an enzyme able to catalyze β -glycosidic bonds cleavage in its macromolecules.

Cellulose is an important constituent of food:

- it binds and removes heavy metals, radio nuclides and other toxic compounds from intestinal tract;
- it stimulates the growth of microorganisms, which produce vitamins B thus strengthening the immune system of a human body;
- it activates peristaltic of intestinal tract.

Dextrans are the homopolysaccharides produced by special bacteria in sucrose solutions. It is used in pharmacology to produce plasma substituent “polyglukin”. It is formed from α -glucose linked by α (1–4) glycosidic bonds in main chain and by α (1–2), α (1–3) and α (1–4) glycosidic bonds at branch points.

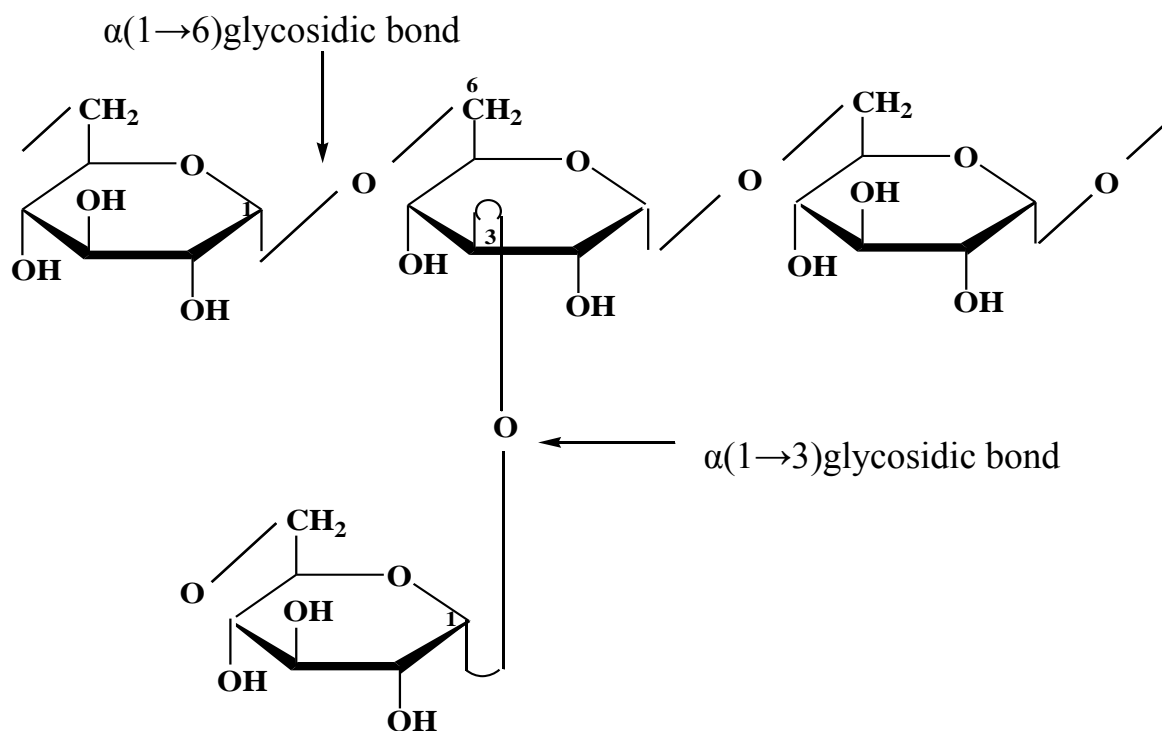

16.10. Heteropolysaccharides

A big group of heteropolysaccharides is known as mucopolysaccharides. Glycosaminoglycans (Mucopolysaccharides) are heteropolysaccharides of connective tissues. They are found in the lubricating fluid of the joints and as components of cartilage, synovial fluid, vitreous humor, bone, and heart valves.

Glycosaminoglycans are long unbranched polysaccharides containing repeating disaccharide units that contain either of two amino sugar compounds: N-acetylgalactosamine or N-acetylglucosamine, and an uronic acid.

Chondroitin sulfate is one of the most important heteropolysaccharide of connective tissue. Its unbranched chains are built up from the disaccharide unit linked by $\beta(1\rightarrow4)$ glycosidic bond. Each unit is built up from D-glucuronic acid and D-galactoseamine joined by $\beta(1\rightarrow3)$ glycosidic bonds. Amino group is acylated by acetic acid and OH-group attached to C-4 or C-6 is acylated by sulfuric acid.

Chondroitin sulfate's disugar fragment.

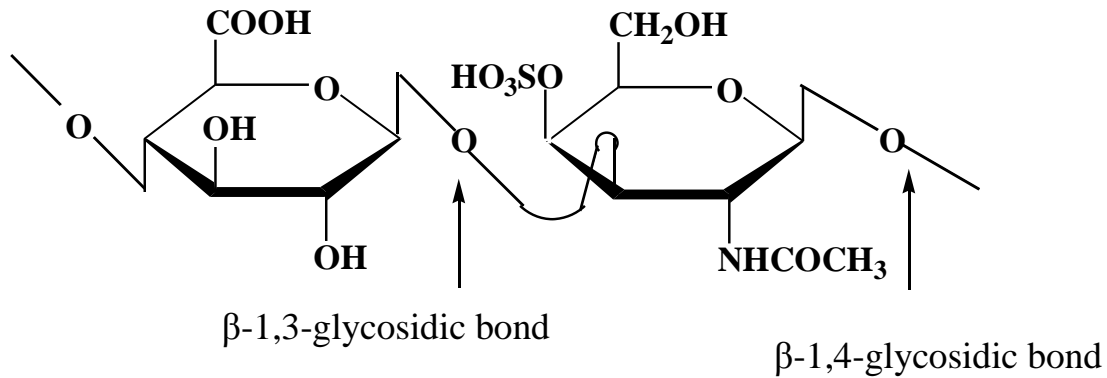

Nonsurgical treatment of knee *osteoarthritis* (OA) focuses on reducing pain and maintaining joint function. In recent years Glucosamine and chondroitin sulfate are dietary supplements taken in pill form that are thought to protect and help repair cartilage cells.

Chondroitin is in dietary supplements used as an alternative medicine to treat osteoarthritis and also approved and regulated as a symptomatic slow-acting drug for this disease (SYSADOA) in Europe and some other countries. It is commonly sold together with glucosamine. Chondroitin and glucosamine are also used in veterinary medicine.

In Hyaluronic acid each disaccharide unit consists from D-Glucuronic acid and ad-glucoseamine linked by $\beta(1\rightarrow3)$ glycosidic bond. It protects tissues from pathogenic bacteria.

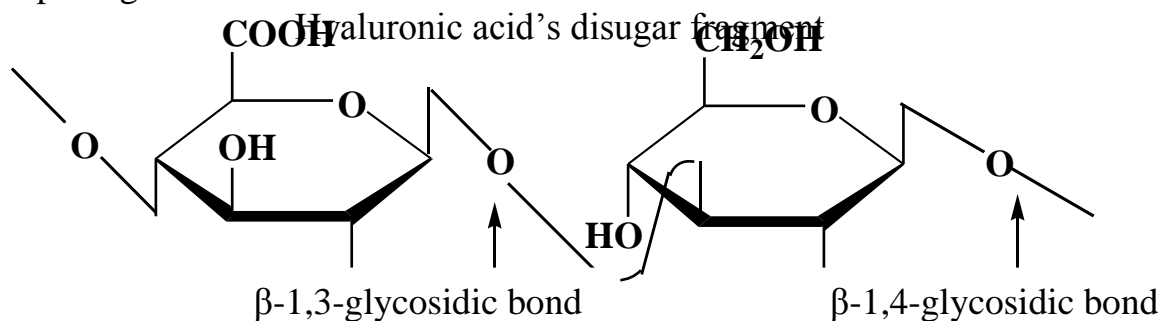

Hyaluronic acid exhibits high viscosity due to which it is not permeable for pathogenic bacteria. Thus it protects organs and tissues from infections.

Hyaluronan has been used in attempts to treat osteoarthritis of the knee via injecting it into the joint. It has not been proven, however, to generate significant benefit and has potentially severe adverse effects.

Dry, scaly skin (xerosis) such as that caused by atopic dermatitis (eczema) may be treated with a prescription skin lotion containing sodium hyaluronate as its active ingredient.

In some cancers, hyaluronan levels correlate well with malignancy and poor prognosis. Hyaluronan is, thus, often used as a tumor marker for prostate and breast cancer. It may also be used to monitor the progression of the disease.

Hyaluronan may also be used postoperatively to induce tissue healing, notably after cataract surgery. Current models of wound healing propose the larger polymers of hyaluronic acid appear in the early stages of healing to physically make room for white blood cells, which mediate the immune response.

Hyaluronan has also been used in the synthesis of biological scaffolds for wound-healing applications. These scaffolds typically have proteins such as fibronectin attached to the hyaluronan to facilitate cell migration into the wound. This is particularly important for individuals with diabetes suffering from chronic wounds.

In 2007, the EMA (European Medicines Agency) extended its approval of Hylan GF-20 as a treatment for ankle and shoulder osteoarthritis pain.

16.11. Laboratory work

DI- AND POLYSACCHARIDES

Test 1: Nonreducing properties of sucrose

Pour 1 drop of 1 % sucrose solution into a test tube and treat it with 6 drops of 10 % sodium hydroxide solution. Dilute the prepared solution with 5-6 drops of water and add 1 drop of 2 % CuSO_4 solution into it. It results in the formation of blue transparent solution of copper (II) complex salt with sucrose.

Heat a prepared solution in the fire of spirit lamp up to the boiling point. Can you see any changes in a solution color? Compare the obtained result with the result of the same experiment with glucose. Make a conclusion about reducing property of sucrose.

Test 2: Reducing properties of lactose

Put 1 drop of 1 % lactose solution into a test tube and treat it with 4 drops of 10 % sodium hydroxide solution. Add 1 drop of 2 % copper (II) sulfate solution into it. Dissolve a prepared copper (II) hydroxide precipitate in lactose solution under stirring. The dissolving results in the formation of blue copper (II) complex salt with lactose solution.

Heat a prepared solution in the fire of spirit lamp up to the boiling point. Can you see any changes in a solution color? Compare the obtained result with the result of the same experiment with glucose. Make a conclusion about reducing property of lactose. Write out the equation for lactose interaction with copper (II) hydroxide.

Test 3: Iodine-starch test

Pour 5 drops of 0.5 % starch colloidal solution into a test tube and treat it with 1 drop of dilute iodine solution. A solution turns blue. Heat a solution. Can you see any changes in its color? Explain why the blue color of iodine-starch complex disappears under heating and appears again under cooling?

Test 4: Acid catalyzed starch hydrolysis

Pour 8–10 drops of starch solution into a test tube and add treat it with 2 drops of concentrated sulfuric acid. Heat a prepared mixture during 20–25 minutes in a glass with boiling water.

Take 1 ml of a solution after hydrolysis with a pipette and treat it with 1 drop of dilute iodine solution. If iodine-starch test is positive treat a solution in a test tube with 8 drops of 10 % NaOH solution and add 1 drop of 2 % copper (II) sulfate solution. What can you see? Is Trommer's test positive or not? Write the equations of fulfilled reactions.

Test 5: Cellulose dissolving in the Schweitzer reagent

The Schweitzer reagent is a copper (II) carbonate ammonia solution. Prepare this solution and put a small piece of cotton into it. A cotton will be dissolved in the Schweitzer reagent under stirring with a glass stick.

Pour approximately 1 ml of a transparent cellulose solution into another test tube and add 4-5 ml of distilled water into it. Pour the mixture into a glass with 10-12 ml of dilute hydrochloric acid. A solution turns colorless and free cellulose releases as white gel looking precipitate.

Does cellulose dissolved in the Schweitzer reagent undergo hydrolysis?

16.12. Exercises for the self-control

1. Draw the Haworth projections for maltose. Give systematic names for these disaccharides. Write out an equation for maltose (lactose) hydrolysis. Explain why maltose (lactose) is a reducing sugar.

2. Write the Haworth projection formula for cyclic and open-chain forms of lactose (milk sugar). Will lactose (maltose) give a positive Fehling's test? Does its solutions mutarotate? Why?

3. Draw the Haworth projection for sucrose. Give systematic name for this disaccharide. Why sucrose is a non reducing sugar? Write an equation for its hydrolysis. Under what conditions does it occur?

4. Name the main difference in structures of glycogen – the energy-storing carbohydrate of animals, and amylopectin – the fraction of starch. Draw a fragment of glycogen macromolecule. Specify glycosidic bonds that join monosaccharide units.

5. Dextrans are homopolysaccharides of bacterial origin. Write The Haworth projection formula for a fragment of its macromolecule. From what mo-

nosaccharide units it is made up? Specify glycosidic bonds that join monosaccharide units. What is dextran's application in medicine?

6. From what monosaccharide units a cellulose macromolecule is built from? Write a formula for the fragment of its macromolecule. Name the type of a glycosidic bond in cellulose.

7. Amylopectin is a fraction of starch, which consists from highly branched macromolecules. From what monosaccharide units it is made up? Describe a fragment of its macromolecule. Specify glycosidic bonds that join monosaccharide units.

CHAPTER 17

α - AMINO ACIDS, PEPTIDES AND PROTEINS

After reading this chapter, you should be able to:

- define α -amino acids and their classification and nomenclature;
- describe biosynthesis of nonessential α -amino acids;
- discuss chemical properties of α -amino acids which lay at the bottom of their functioning *in vivo*;
- define structure and nomenclature of polypeptides chains;
- describe electron structure of a peptide bond;
- discuss primary structure of proteins determination;
- explain strategy of peptide synthesis;
- summarize chemical properties of peptides and proteins.

Proteins are natural polymers composed of **amino acids** joined one to another by amide (or peptide) bonds. They are essential to the structure, function and reproduction of living matter. In this chapter, we will first discuss the structure and properties of amino acids then the properties of **peptides**, which consist of just a few linked amino acids, and finally, the structures of proteins.

17.1. α -Amino Acid

17.1.1. Naturally Occurring Amino Acids

The amino acids obtained from proteins hydrolysis are **α -amino acids**. That is, the amino group is on the α -carbon atom, the one adjacent to the carboxyl group. General formula for α -amino acid is:

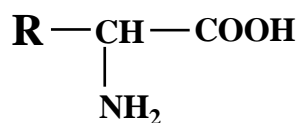

α -Amino acids are solid crystalline substance soluble in water. Many of them have a sweet taste. The total number of naturally occurring amino acids is about 300, but some of them are found only in certain communities or even in

one organism. Among them is a group of 20 of the most important α -amino acids are constantly found in all proteins (Table 17.1). The amino acids in Table 17.1 are grouped to emphasize structural similarities.

The amino acids are known by common names. Each also has a three-letter abbreviation based on this name, which is used when writing the formulas of peptides.

Nowadays there are several types of α -amino acids classifications. First of all they are classified according to their molecular framework. According to this feature, α -amino acids are subdivided into aliphatic, aromatic and heterocyclic (Figure 17.1).

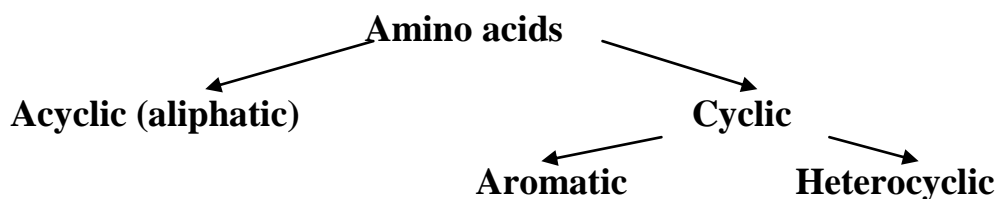
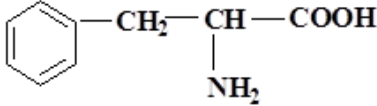
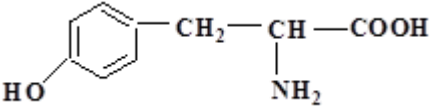
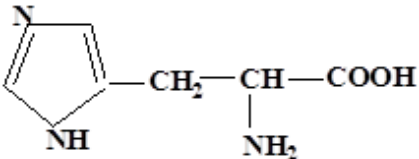
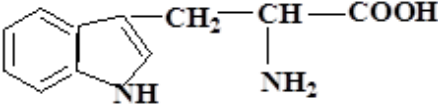
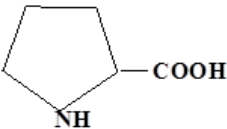
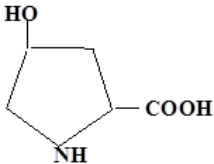

Figure 17.1 — Classification of α -amino acids according to their molecular framework

Table 17.1. — Names and formulas of the common α -amino acids

| Common name and three-letter abbreviation | Formula | Systematic name |
|---|--|----------------------------------|
| Aliphatic monoamino monocarboxylic acids | | |
| Glycine (Gly) | $\text{H}_2\text{N}-\text{CH}_2-\text{COOH}$ | amino ethanoic acid |
| Alanine (Ala) | $\begin{array}{c} \text{CH}_3-\text{CH}-\text{COOH} \\ \\ \text{NH}_2 \end{array}$ | 2-aminopropanoic acid |
| Serine (Ser) | $\begin{array}{c} \text{CH}_2-\text{CH}-\text{COOH} \\ \quad \\ \text{OH} \quad \text{NH}_2 \end{array}$ | 2-amino-3-hydroxypropanoic acid |
| Cysteine (Cys) | $\begin{array}{c} \text{CH}_2-\text{CH}-\text{COOH} \\ \quad \\ \text{SH} \quad \text{NH}_2 \end{array}$ | 2-amino-3-mercaptopropanoic acid |
| Valine (Val) | $\begin{array}{c} \text{CH}_3-\text{CH}-\overset{*}{\text{C}}\text{H}-\text{COOH} \\ \quad \\ \text{CH}_3 \quad \text{NH}_2 \end{array}$ | 2-amino-3-methylbutanoic acid |

| Common name and three-letter abbreviation | Formula | Systematic name |
|---|---|-----------------------------------|
| Threonine (Thr) | $\begin{array}{ccccccc} \text{CH}_3 & - & \text{CH} & - & \text{CH} & - & \text{COOH} \\ & & & & & & \\ & & \text{OH} & & \text{NH}_2 & & \end{array}$ | 2-amino-3-hydroxybutanoic acid |
| Leucine (Leu) | $\begin{array}{ccccccc} \text{CH}_3 & - & \text{CH} & - & \text{CH}_2 & - & \text{CH} & - & \text{COOH} \\ & & & & & & & & \\ & & \text{CH}_3 & & & & \text{NH}_2 & & \end{array}$ | 2-amino-3-methylpentanoic acid |
| Isoleucine (Ile) | $\begin{array}{ccccccc} \text{CH}_3 & - & \text{CH}_2 & - & \text{CH} & - & \text{CH} & - & \text{COOH} \\ & & & & & & & & \\ & & & & \text{CH}_3 & & \text{NH}_2 & & \end{array}$ | 2-amino-3-methylpentanoic acid |
| Methionine (MET) | $\begin{array}{ccccccc} \text{CH}_2 & - & \text{CH}_2 & - & \text{CH} & - & \text{COOH} \\ & & & & & & \\ \text{S} & - & \text{CH}_3 & & \text{NH}_2 & & \end{array}$ | 2-amino-4-methylthiobutanoic acid |
| Aliphatic monoamino dicarboxylic acids | | |
| Aspartic acid (Asp) | $\begin{array}{ccccccc} \text{CH}_2 & - & \text{CH} & - & \text{COOH} \\ & & & & \\ \text{COOH} & & \text{NH}_2 & & \end{array}$ | 2-amino butanedioic acid |
| Glutamic acid (Glu) | $\begin{array}{ccccccc} \text{CH}_2 & - & \text{CH}_2 & - & \text{CH} & - & \text{COOH} \\ & & & & & & \\ \text{COOH} & & & & \text{NH}_2 & & \end{array}$ | 2-aminopentanedioic acid |
| Asparagine (Asn) | $\begin{array}{ccccccc} \text{CH}_2 & - & \text{CH}_2 & - & \text{CH} & - & \text{COOH} \\ & & & & & & \\ \text{COOH} & & & & \text{NH}_2 & & \end{array}$ | 2-aminopentanedioic acid |
| Glutamine (Gln) | $\begin{array}{ccccccc} \text{O} & & & & & & \\ & & & & & & \\ \text{NH}_2 & - & \text{C} & - & \text{CH}_2 & - & \text{CH} & - & \text{COOH} \\ & & & & & & \\ & & & & \text{NH}_2 & & \end{array}$ | Aspartic acid amide |
| | $\begin{array}{ccccccc} \text{O} & & & & & & \\ & & & & & & \\ \text{NH}_2 & - & \text{C} & - & \text{CH}_2 & - & \text{CH}_2 & - & \text{CH} & - & \text{COOH} \\ & & & & & & \\ & & & & \text{NH}_2 & & \end{array}$ | Glutamic acid amide |
| Aliphatic diamino monocarboxylic acids | | |
| Lysine (Lys) | $\begin{array}{ccccccc} (\text{CH}_2)_4 & - & \text{CH} & - & \text{COOH} \\ & & & & \\ \text{NH}_2 & & \text{NH}_2 & & \end{array}$ | 2,6-diaminohexanoic acid |
| Arginine (Arg) | $\begin{array}{ccccccc} \text{H}_2\text{N} & - & \text{C} & - & \text{NH} & - & \text{CH}_2 & - & \text{CH}_2 & - & \text{CH}_2 & - & \text{CH} & - & \text{COOH} \\ & & & & & & & & & & \\ & & \text{NH} & & & & & & \text{NH}_2 & & \end{array}$ | 2-amino-5-guanidylpentanoic acid |

| Common name and three-letter abbreviation | Formula | Systematic name |
|---|---|---|
| Aromatic amino acids | | |
| Phenylalanine (Phe) |  | 2-amino-3-phenyl propanoic acid |
| Tyrosine (Tyr) |  | 2-amino-3-(4-hydroxy phenyl)-propanoic acid |
| Heterocyclic amino acids | | |
| Histidine (His) |  | 2-amino-3-imidazolyl propanoic acid |
| Tryptophan (Trp) |  | 2-amino-3-indolyl propanoic acid, |
| Proline (Pro) |  | pyrrolidine-2-carboxylic acid |
| Hydroxy proline (HO-Pro) |  | 4-hydroxy pyrrolidine-2-carboxylic acid |

Aliphatic amino acids make up the most numerous group. The aliphatic radicals may contain additional functional groups, such as hydroxyl (serine, threonine), thiol (cysteine) and amide (asparagine, glutamine) groups.

Another way of α -amino acids classification divides them into three groups according to the number of amino- and carboxyl groups in the molecules. They are:

- mono amino monocarboxylic acids (neutral);
- mono amino dicarboxylic acids (acidic);
- diamino monocarboxylic acids (basic).

In the chemistry of amino acids much attention is paid to the structure and properties of radicals **R**, which play an important role in determining the structure of proteins and the performance of their biological functions. Here we consider such features as radicals' polarity, the presence of functional groups and the ability of these groups to ionization. Depending on the nature of a side radical amino acids fall into two groups: with **non-polar (hydrophobic)** and **polar (hydrophilic)** radicals.

The second group includes amino acids which have radicals that contain polar functional groups able of ionization (ionisable groups) or not able of ionization (non-ionisable groups) in a body. Classification of α -amino acids according to polarity of their radicals is given in Figure 17.2.

For example, OH-group in tyrosine molecule is ionizable, while OH-group in serine is not ionisable:

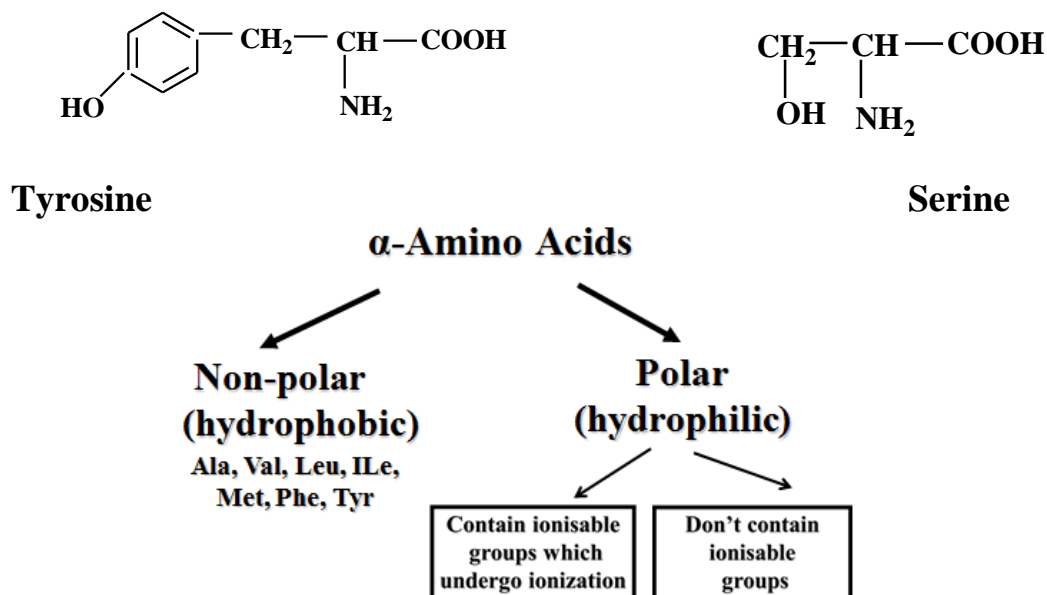
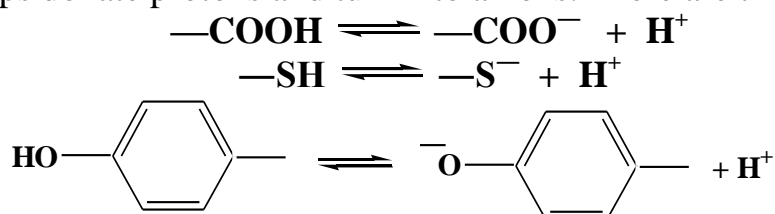
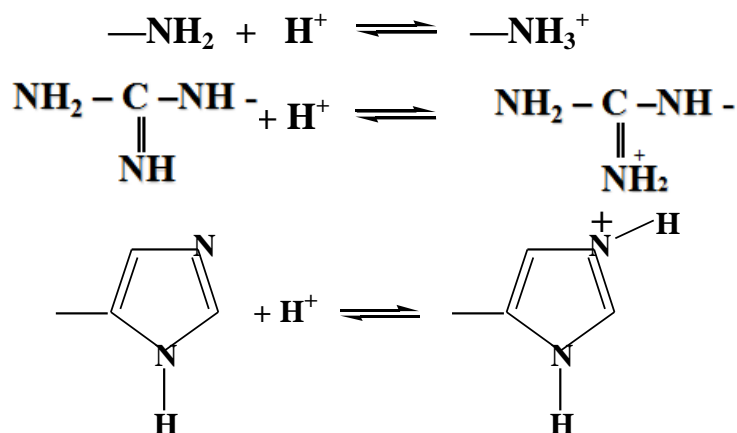

Figure 17.2 — Classification of α -amino acids according to polarity of their radicals

Ionisable groups, in its turn, fall into two categories: acidic and basic. Acidic ionisable groups donate protons and turn into anions. There are three of them:



Basic ionisable groups accept protons and turn into cations. There are three of them:



In proteins, the ionisable groups are generally located on the surface of macromolecules and are responsible for electrostatic interactions. Non-ionisable polar groups may be stationed at the surface as well as inside protein molecules. They are involved in formation of hydrogen bonds with other polar groups.

Of the 20 amino acids that present in all proteins, 12 can be synthesized in the body, but the other 8 are referred to as **essential amino acids**, that cannot be synthesized by adult humans and therefore must be included in the diet in the form of proteins. They are **Val, Leu, Ile, Thr, Met, Lys, Phe and Trp**. In some diseases, often congenital the list of essential amino acids, it expanded. For example, the lack of a necessary enzyme makes tyrosine an essential amino acid and causes such a disease as phenylketonuria — a brain-damaging genetic disease. Histidine and arginine are generally considered essential only in children, because of their inability to synthesize them.



GLYCINE

Helps trigger the release of oxygen to the energy requiring cell-making process; important in the manufacturing of hormones responsible for a strong immune system.

ALANINE

Is an important source of energy for muscle tissue, the brain and central nervous system; strengthens the immune system by producing antibodies; helps in the metabolism of sugars and organic acids.

SERINE

A storage source of glucose by the liver and muscles; helps strengthen the immune system by providing antibodies; synthesizes fatty acid sheath around nerve fibers.

METHIONINE

Is a principle supplier of sulfur which prevents disorders of the hair, skin and nails; helps lower cholesterol levels by increasing the liver's production of lecithin; reduces liver fat and protects the kidneys; a natural chelating agent for heavy metals. Methionine is a protein-based amino acid and lipotropic compound that helps with metabolism and breaks down fat. It can also help with chelation, which is the removal of heavy metals from the body to ensure that the liver, kidneys, and bladder remain healthy. This amino acid preserves artery function and maintains healthy nails, hair, and skin. Additionally, it is essential for muscle growth and energy.

VALINE

Promotes mental vigor, muscle coordination and calm emotions.

THREONINE

Is an important constituent of collagen, elastin, and enamel protein; helps prevents fat build-up in the liver; helps the digestive and intestinal tracts function more smoothly.

LEUCINE & ISOLEUCINE

They provide ingredients for the manufacturing of other essential biochemical components in the body, some of which are utilized for the production of energy, stimulants to the upper brain and helping you to be more alert.

GLUTAMIC ACID

Considered to be nature's "Brain food" by improving mental capacities; helps speed the healing of ulcers; gives a "lift" from fatigue; helps control alcoholism, schizophrenia and the craving for sugar.

ASPARTIC ACID

Aids in the expulsion of harmful ammonia from the body. Recent studies have shown that Aspartic Acid may increase resistance to fatigue and increase endurance.

LYSINE

Insures the adequate absorption of calcium; helps to form collagen; aids in the production of antibodies, hormones & enzymes. Recent studies have shown that Lysine may be effective against herpes by improving the balance of nutrients that reduce viral growth. A deficiency may result in tiredness, inability to concentrate, bloodshot eyes, retarded growth, hair loss, anemia & reproductive problems.

ARGININE

Studies have shown that it has improved immune responses to bacteria, viruses & tumor cells; promotes wound healing and regeneration of the liver; considered crucial for optimal muscle growth and tissue repair.

PHENYLALANINE

Used by the brain to produce Noradrenalin, a chemical that transmits signals between nerve cells and the brain; functions as an antidepressant and helps to improve memory.

TYROSINE

Transmits nerve impulses to the brain; helps overcome depression; improves memory; increases mental alertness; promotes the healthy functioning of the thyroid, adrenal and pituitary glands.

TRYPTOPHAN

A natural relaxant, helps alleviate insomnia by inducing normal sleep; reduces anxiety & depression; helps in the treatment of migraine headaches; helps to reduce the risk of artery & heart spasms; works with Lysine in reducing cholesterol levels.

HISTIDINE

Is found abundantly in hemoglobin; has been used in the treatment of rheumatoid arthritis, allergic diseases, ulcers & anemia. A deficiency can cause poor hearing.

PROLINE

Is extremely important for the proper functioning of joints and tendons; also helps maintain and strengthen heart muscles.

17.1.2. Stereoisomerism of α -Amino Acids

All α -amino acids are chiral, except glycine. They contain stereogenic centers and form optical stereoisomers. Their relative configuration is determined according to glyceraldehyde, traditionally applied as Configurational standard in stereochemistry.

Most α -amino acids contain only one stereogenic center and exist as two optically active enantiomers and optically inactive racemic mixture. Almost all natural α -amino acids belong to L-optical family. It was proved that only L-amino acids are involved into proteins' biosynthesis

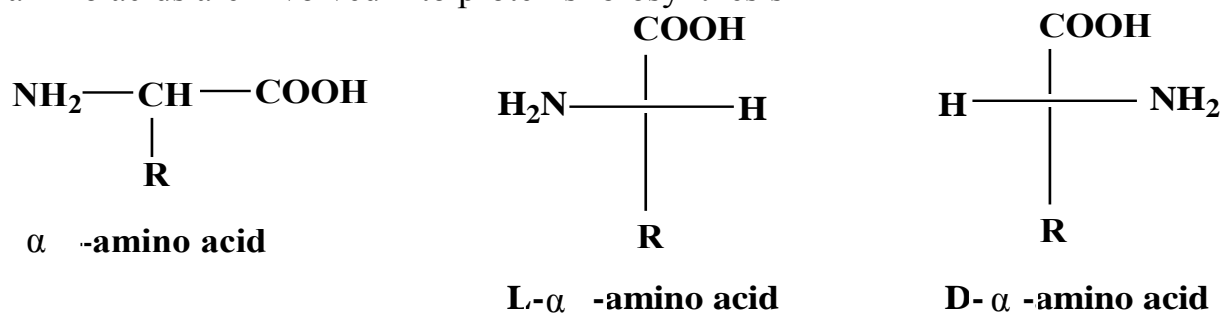

Given below are L-stereoisomer of alanine, valine and methionine:

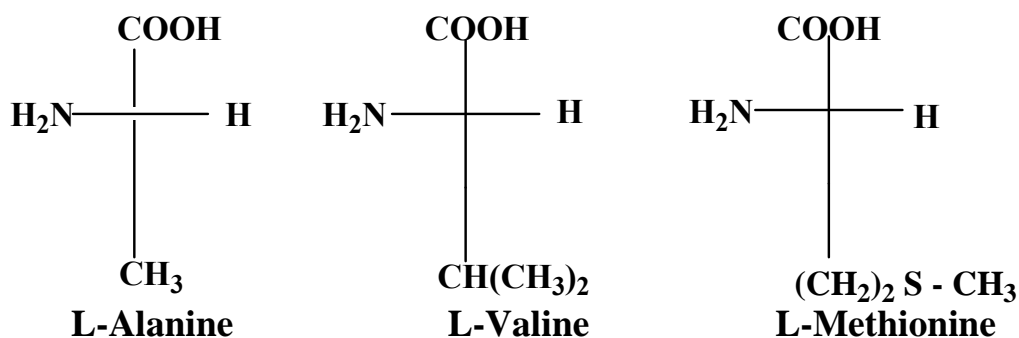

Such α -amino acids as isoleucine, threonine and 4-hydroxy proline contain two stereogenic centers in their molecules:

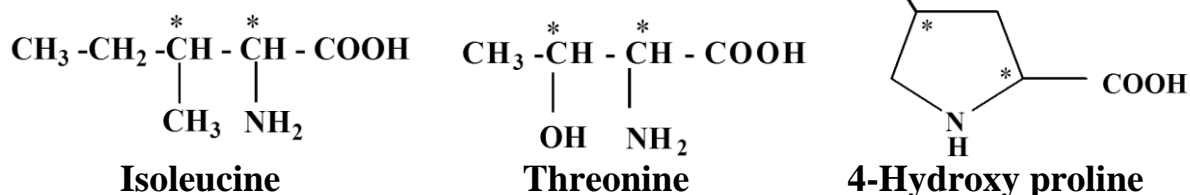

Each of these amino acids has four stereoisomers and two pairs of enantiomers, but only one stereoisomer is involved into proteins biosynthesis. Below are the stereoisomers of isoleucine:

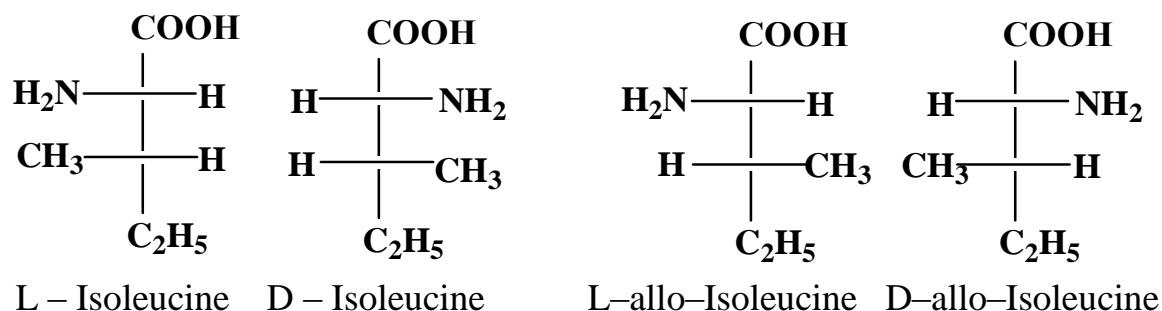

Only L — isoleucine is involved into proteins biosynthesis, while L–allo–isoleucine doesn't behave as a structural unit of proteins. The prefix “allo” (from Greek, allos) is translated as foreign or enthetic. Stereoisomers of threonine are considered in Chapter 12.

Using only the L-stereoisomers for building proteins of the human body is essential to the formation of the spatial structure of proteins. From this is directly linked the stereospecificity of enzyme action. Enzymes macromolecules built by chiral molecules of α -amino acids are generally chiral and therefore react only with substrates which also have a particular configuration.

D- α -amino acids are found in many natural peptides produced by microorganisms. For example, they are contained in certain antibiotics (dactinomycin and po-lymyxin) as well as in biopolymers of the bacterial cell walls.

17.1.3. Biosynthesis of α -Amino Acids

The body can manufacture a number of α -amino acids from intermediates that appear in the catabolism of non-protein substances. The precursors of α -amino acids in a body are α -keto acids. There are two pathways for the biosynthesis of α -amino acids: reductive amination, and transamination.

Reductive amination involves the use of ammonia as a source of the amino group and NAD•H as a reducing agent. The scheme of a-ketoglutaric acid conversion into glutamic acid is given below:

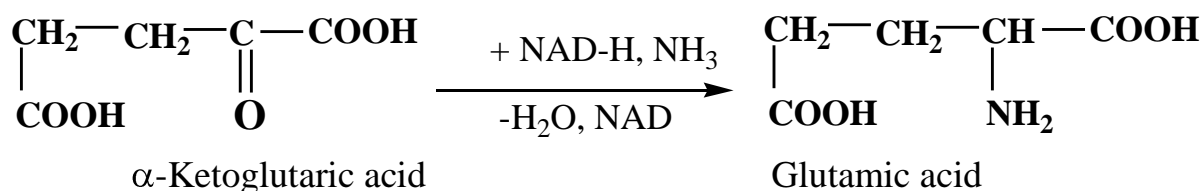

Transamination (or aminotransfer) is a chemical reaction between two molecules. One is an amino acid and the other is a keto acid. In transamination, the NH_2 group on one molecule is exchanged with the $\text{C}=\text{O}$ group on the other molecule. The amino acid becomes a keto acid, and the keto acid becomes an amino acid. Transamination in biochemistry is accomplished by enzymes called **transaminases** or **aminotransferases**. This reaction uses the coenzyme **pyridoxamine phosphate**, which is converted into **pyridoxal phosphate** after the reaction, and has been shown to be a kinetically perfect reaction. The product of transamination reactions depend on the availability of alpha-keto acids. The products usually are alanine, aspartate or glutamate, since their corresponding alpha-keto acids are produced through metabolism of fuels. The chirality of an amino acid is determined during transamination. The transformation of oxaloacetic acid into aspartic acid is shown below:

The amino group can be acylated to an amide:

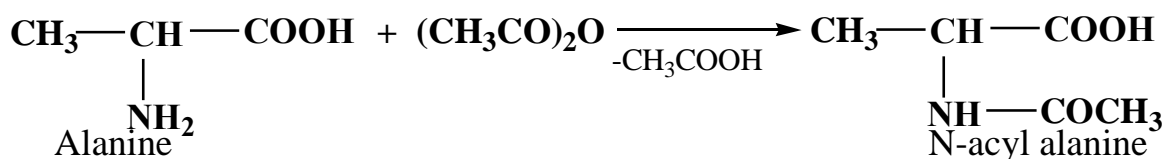

These types of reactions are useful in temporarily modifying or protecting either of the two functional groups, especially during the controlled linking of amino acids to form peptides or proteins.

17.1.6. Biologically Important Chemical Reactions of α -Amino Acids

Chemical reactions, which will be discussed in this section takes place in all living organisms under the influence of enzymes. Some of them can be performed *in vitro*.

Decarboxylation of α -amino acids (removal of carbon dioxide) is a main pathway for biological amines formation in a body. Decarboxylation is catalyzed by the enzyme **decarboxylase** and coenzyme **pyridoxal phosphate**. For example, decarboxylation of glutamic acid results in γ -amino butyric acid production, which behaves as a neuromodulator:

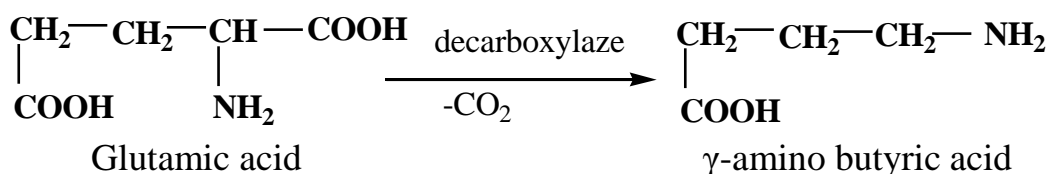

In the laboratory decarboxylation of amino acids proceeds upon heating in the presence of barium hydroxide, that absorbs evolved carbon dioxide.

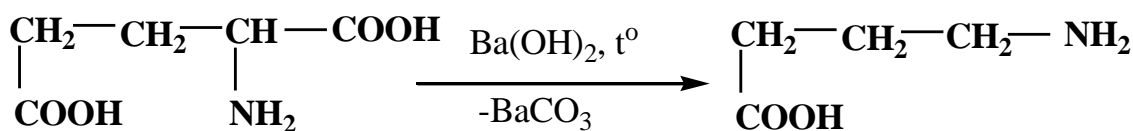

Decarboxylation of serine, cysteine, lysine, tryptophan, histidine and some other α -amino acids is of great biological importance.

Deamination of α -amino acids (removal of amino groups) *in vivo* may be direct and oxidative. **Direct deamination *in vivo*** results in formation of unsaturated carboxylic acids:

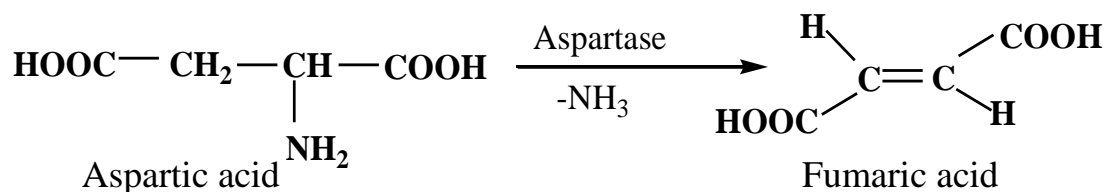

Oxidative deamination *in vivo* involves NAD^+ as an oxidizing agent. The process involves two steps. In the first step amino acid is oxidized to imino acid; in the second step an imino acid is hydrolyzed into a keto acid:

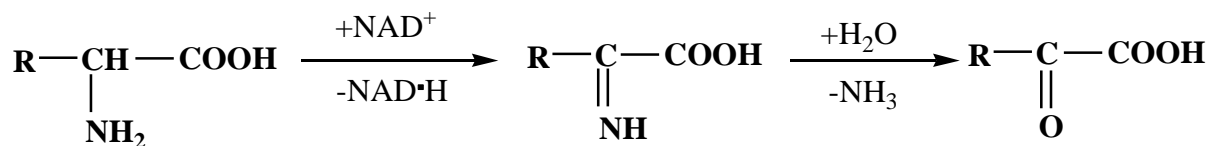

In the laboratory **oxidative deamination** is carried out with nitrous acid. This produces the corresponding α -hydroxy acid and nitrogen gas. By measuring the amount of released nitrogen the amount of α -amino acids can be calculated (Van-Slake Method):

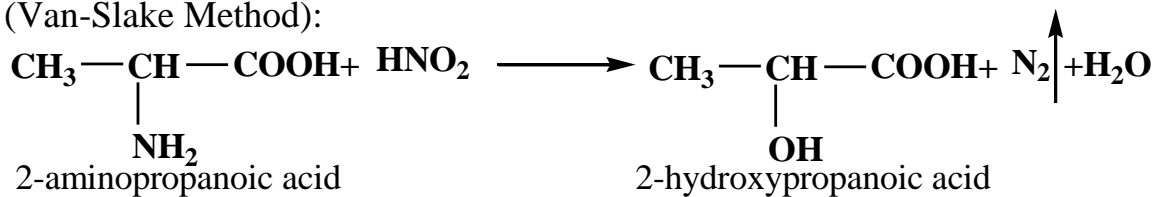

Hydroxylation is a chemical process that introduces a hydroxyl group (-OH) into an organic compound. In biochemistry, hydroxylation reactions are often facilitated by enzymes called hydroxylases. Hydroxylation is an oxidative process. The oxygen that is inserted into the C-H bond is usually derived from atmospheric oxygen (O_2). Since O_2 itself is a slow hydroxylating agent, catalysts are required to accelerate the pace of the process. **Phenylalanine hydroxylase** is an enzyme that catalyzes the hydroxylation of the aromatic side-chain of phenylalanine to generate tyrosine:

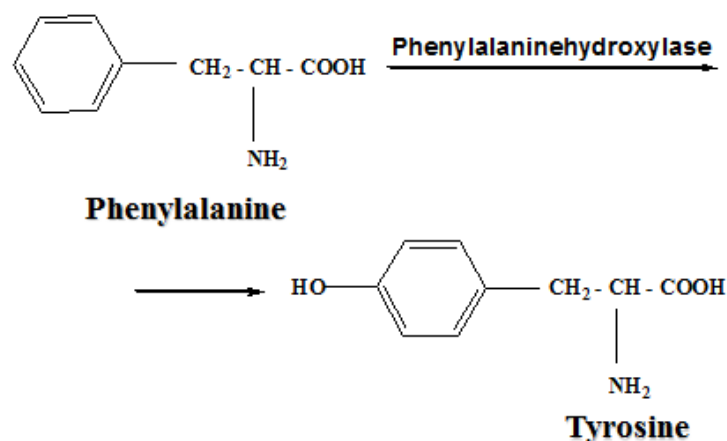

The enzyme is also interesting from a human health perspective because mutations in it, the encoding gene, can lead to phenylketonuria, a severe metabolic disorder, a brain-damaging genetic disease.

Other examples of hydroxylation *in vivo* are the reactions of proline transformation into 4-hydroxyproline, tyrosine – into 3, 4-dihydroxyphenylalanine (DOPA), and tryptophan- into 5-hydroxytryptophan.

17.2. Peptides and Proteins

Peptides and proteins are compounds built of α -amino acid residues. Conventionally considered that the peptides contain less than 100 and the proteins - greater than 100 amino acid residues in their molecules. Most natural polypeptide (proteins) chains contain between 50 and 2000 amino acids. Most polypeptides have a molecular mass of about 5,500 to 220,000.

In its turn, the group of **oligopeptides**, containing not more than 10 amino acid residues, and the group of **polypeptides**, containing up to 100 amino acid residues, can be distinguished.

Proteins are biopolymers that play numerous roles in biological systems. Some proteins are major components of structural tissue (muscle, skin, nails, and hair). Others transport molecules from one part of a living system to another. Yet others serve as catalysts for the many biological reactions needed to sustain life. In the remainder of this chapter, we will describe the main features of peptide and protein structure.

17.2.1. Electron Structure of the Peptides Bond

In peptides and proteins α -amino acids residues are linked by **amide (peptide) bond**. This amide bond was called a peptide bond by Emil Fischer, who first proposed the primary structure for proteins.

This bond arises between the carboxyl group of one amino acid and the α -amino group of another amino acid. Interaction between two amino acids, which leads to the formation of the peptide bond, is shown in Figure 17.3.

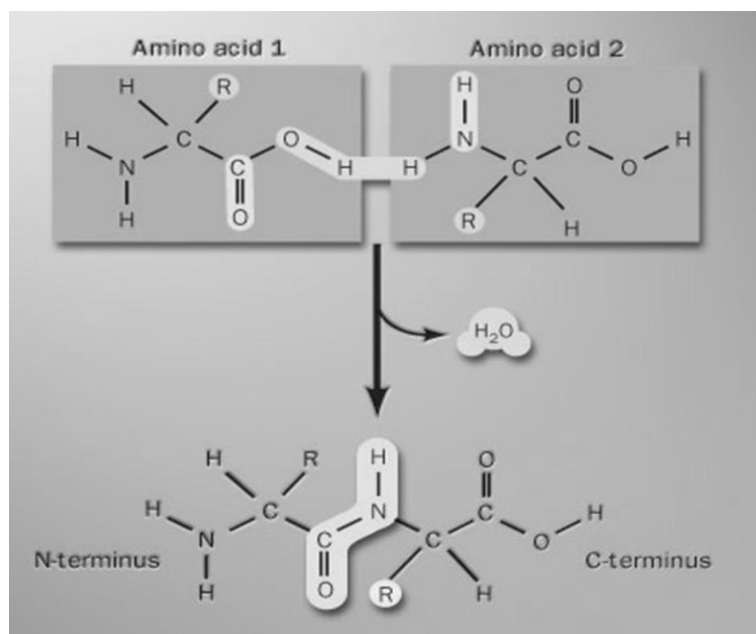

Figure 17.3 — The scheme of peptide bond formation

The peptide bond supports the primary structure of peptides and proteins. **The primary structure** of peptides and proteins is the sequence of α -amino acid residues in a completely assembled polypeptide chain. The primary structure begins with the first amino acid residue at the N-terminal end and progresses in sequence to the last amino acid at the C-terminal end.

Hermann Emil Louis Fischer (1852–1919) was a German chemist and 1902 recipient of the Nobel Prize in Chemistry. He discovered the Fischer esterification, developed the Fischer projection, a symbolic way of drawing asymmetric carbon atoms. He was the first who proposed the primary structure for proteins. It was Emil Fisher who named the amide bond as the peptide bond.



In order to illustrate this statement a general formula for a **tripeptide** is given below:

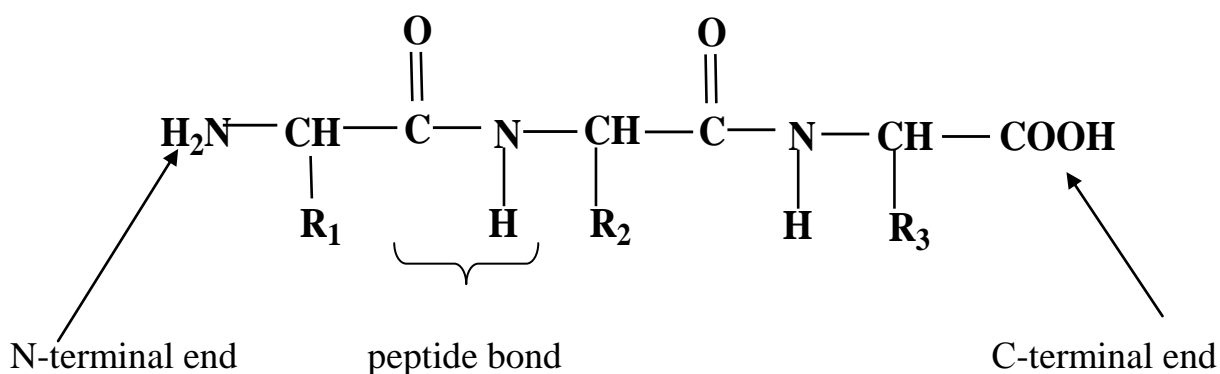

As you can see, the backbone of peptides and proteins is a repeating sequence of one nitrogen and two carbon atoms. R_1 , R_2 and R_3 are the radicals, connected with α -carbons in amino acids' molecules.

Consider the structural formula of a tripeptide composed of glycine, alanine and lysine:

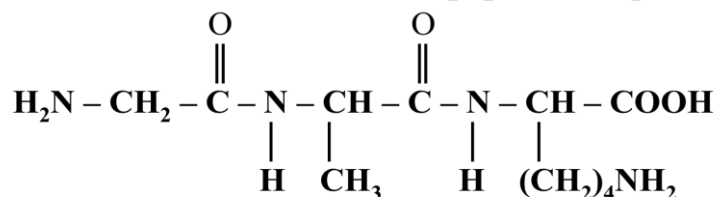

The names of the peptides are constructed by sequential enumeration of amino acid residues starting from the N-terminal end, with the addition of the suffix *-yl*, except the last acid, for which retained its full title. Thus the given tripeptide is named **glycylalanyllysine**, or in short **Gly-Ala-Lys**.

Peptides and proteins exhibit acid-base duality since they contain both acidic and basic ionisable groups. **Thus proteins are amphoteric or amphiprotic polyelectrolytes**. The medium in peptides and proteins water solutions depends upon the number acidic and basic groups in their molecules.

For example, the solution of a dipeptide **Gly – Ala** is approximately neutral (pH \approx 7) because it contains one acidic group ($-\text{COOH}$) and one basic group ($-\text{NH}_2$):

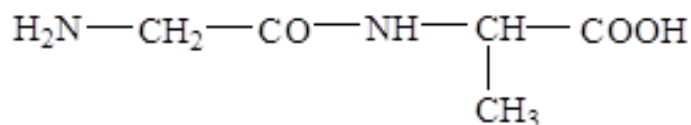

Peptides and proteins are characterized by their isoelectric point (pI). **Isoelectric point** is the pH of a solution that contains dipolar ions of peptides or proteins:



The isoelectric state of the dipeptide Gly – Ala is represented by the following formula:

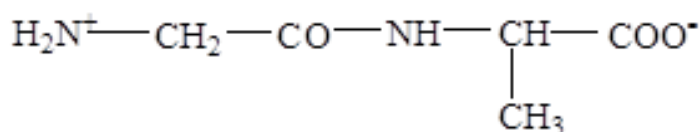

For neutral peptides and proteins their isoelectric points also comes in a neutral medium (pI \approx 7).

The water solution of a dipeptide **Gly-Glu** is acidic (pH $<$ 7), because it contains two acidic groups and only one basic ionizable group:

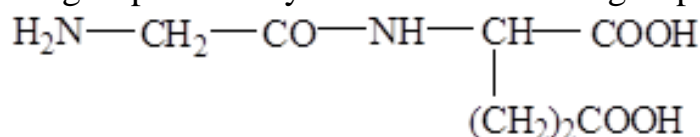

The dipolar ion of this peptide is given below:

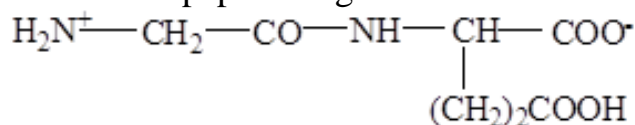

For acidic peptides the isoelectric points comes in an acidic medium (pI $<$ 7).

The water solution of a dipeptide **Gly – Lys** is basic (pH $>$ 7), since it contains two basic groups and only one acidic group:

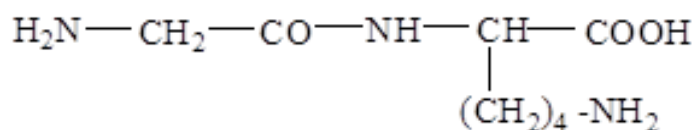

The dipolar ion of this peptide is given below:

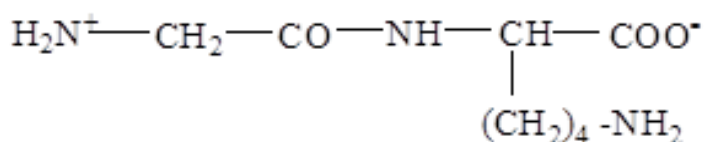

For basic peptides the isoelectric points comes in a basic medium (pI $>$ 7).

Biological functions of peptides and proteins depend upon a peptide group (unit) structure. **The peptide group is planar and rigid.** It is planar due to car-

carbonyl carbon sp^2 -hybridization. σ -Bonds of carbonyl carbon lay in one plane with angles between them 120° . Hydrogen of the substituted amino group is nearly always trans (opposite) to the oxygen of carbonyl group (Figure 17.4).

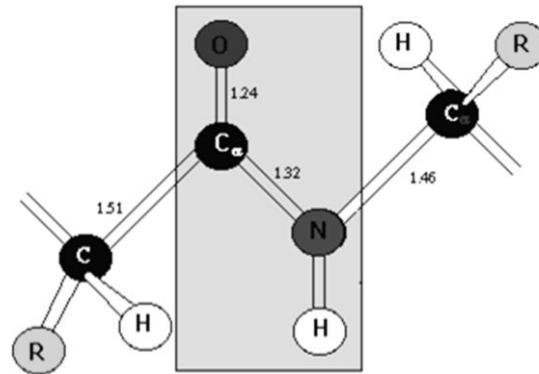
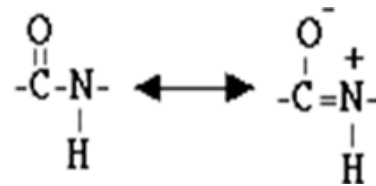

Figure 17.4 — The peptide group is planar with hydrogen of the substituted amino group is nearly always trans (opposite) to the oxygen of carbonyl group

The peptide group is rigid since there is no freedom of rotation about it because of its partial double-bond character. A partial double bonding is the result of p,π -conjugation between lone electron pair of nitrogen and π -electrons of the carbonyl group. We can say that the peptide group exists in a form of two resonance structures:



The partial double-bonding of the peptide bond is proved by the following experimental data: the length of C—N single bond is 0.14 nm, the length of C=N double bond is 0.127 nm, but the length of C—N bond in a peptide bond is 0.132 nm.

In contrast there is a large degree of rotational freedom about the α -carbon and a peptide group (Figure 17.5).

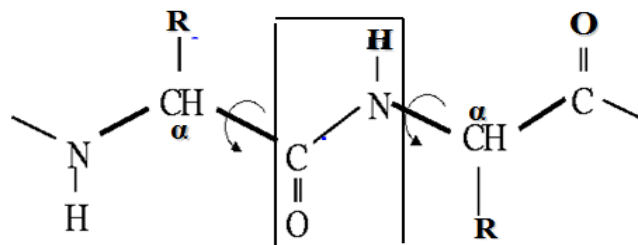

Figure 17.5 — Rotations of atoms about the α -carbon and a peptide group give rise to the huge number of polypeptide chain conformations

Theoretically these rotations must give rise to the huge number of polypeptide chain conformations, but practically only two of them were proved to be stable. They are α -helix and β -strand, known as the secondary structure of proteins.



Some naturally Occurring Peptides

Peptides with just a few linked amino acids per molecule have been isolated from living matter, where they often perform important roles in biology. Here are a few examples.

Bradykinin is a nonapeptide presents in blood plasma and is involved in regulating blood pressure:



Oxytocin is cyclic nonapeptide hormone produced by the posterior pituitary gland. Oxytocin regulates uterine contraction and lactation:

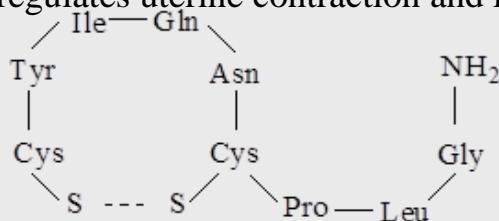

Vasopressin regulates the excretion of water by the kidneys and also affects blood pressure.

Cyclosporin A has immunosuppressive activity and is used to help prevent organ rejection after transplant operations.

One of the most common natural tripeptide **glutathione** is contained in all plants, animals and bacteria:

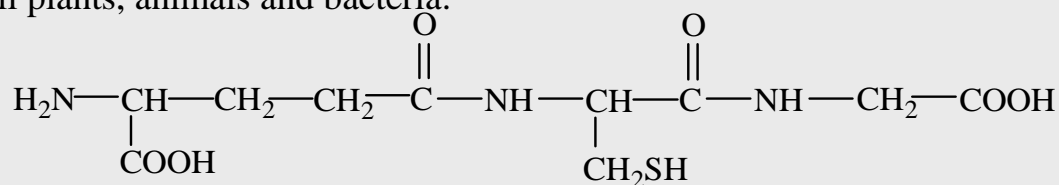

γ -Glu-Cys-Gly

The presence of cysteine as part of glutathione causes the possibility of the latter in the reduced and oxidized forms. Glutathione is involved in a number of redox processes. It serves as a protector of protein that is a substance which protects proteins with free thiol groups from oxidation to form disulfide bonds.

At present dipeptide **aspartame** having nearly 200 times sweeter taste than sucrose is industrially produced. It is composed of L-aspartic acid and methyl ester of phenyl alanine:

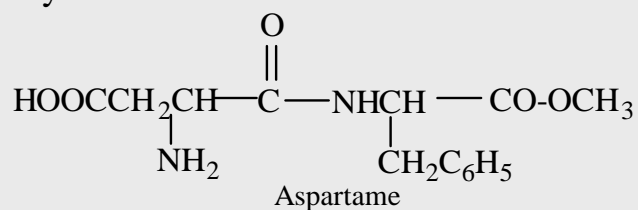

Phenylalanine and aspartic acid are amino acids and are naturally present in many foods that contain protein. They do not cause health problems in most people. However people with the disease phenylketonuria need to restrict their intake of phenylalanine, and so are usually counseled to avoid aspartame.

17.2.2. Primary Structure of Proteins Determination

The primary structure of peptides and proteins may be determined by sequence elimination of N-terminal amino acids with their later identification. Now days there are a lot of such methods. Amino acid sequences are important for several reasons:

- analyses of amino acid sequence is uncovering the rules of folding of peptide chains;
- the sequence is needed for studying molecular pathology (sickle-cell anemia);
- sequence reveals much about proteins' evolutionary history.

Frederick Sanger from Cambridge University devised a method for sequencing peptides based on the observation that the N-terminal amino acid differs from all others in the chain by having a free amino group. If that amino group were to react with some reagent prior to hydrolysis, then after hydrolysis, that amino acid would be labeled and could be identified. **Sanger's reagent** is 2,4-dinitrofluorobenzene, which reacts with the NH_2 group of amino acids and peptides to give yellow 2,4-dinitrophenol (DNP) derivatives. Hydrolysis of a peptide treated this way would give the DNP derivative of the N-terminal amino acid; other amino acids in the chain would be unlabeled. In this way, the N-terminal amino acid could be identified. The steps in Sanger's method are shown in the following scheme:

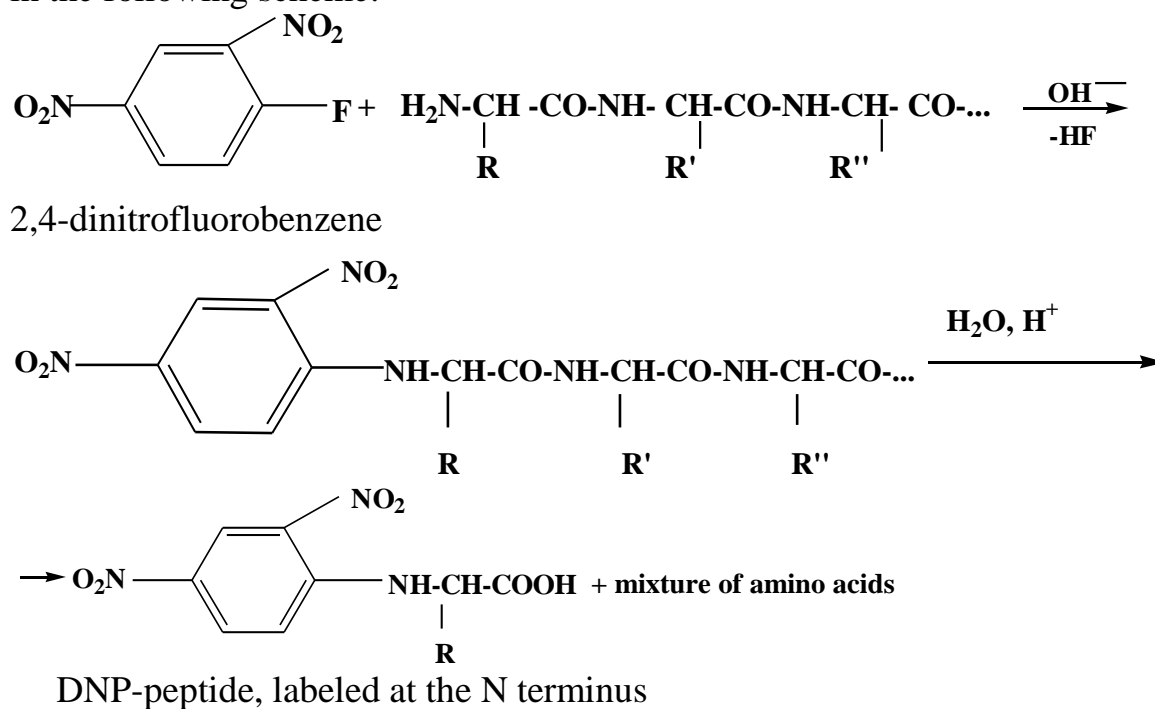

Sanger used this method with great ingenuity to deduce the complete sequence of insulin, a protein hormone with 51 amino acid units. But the method suffers in that it identifies only the N-terminal amino acid.

Frederick Sanger received two Nobel Prizes, the first in 1958 for his landmark work in amino acid sequencing and the second in 1980 for methodology in the base sequencing of RNA and DNA.

An ideal method for sequencing a peptide or protein was devised by **Pehr Edman** (professor at the University of Lund in Sweden, 1950). **Edman's reagent** (phenyl isothiocyanate) clips off just one amino acid at a time from the end of a chain and identifies it by chromatographic methods. A polypeptide chain becomes shorter but not destroyed.

The steps in selectively labeling and releasing the N-terminal amino acid are shown in the following scheme:

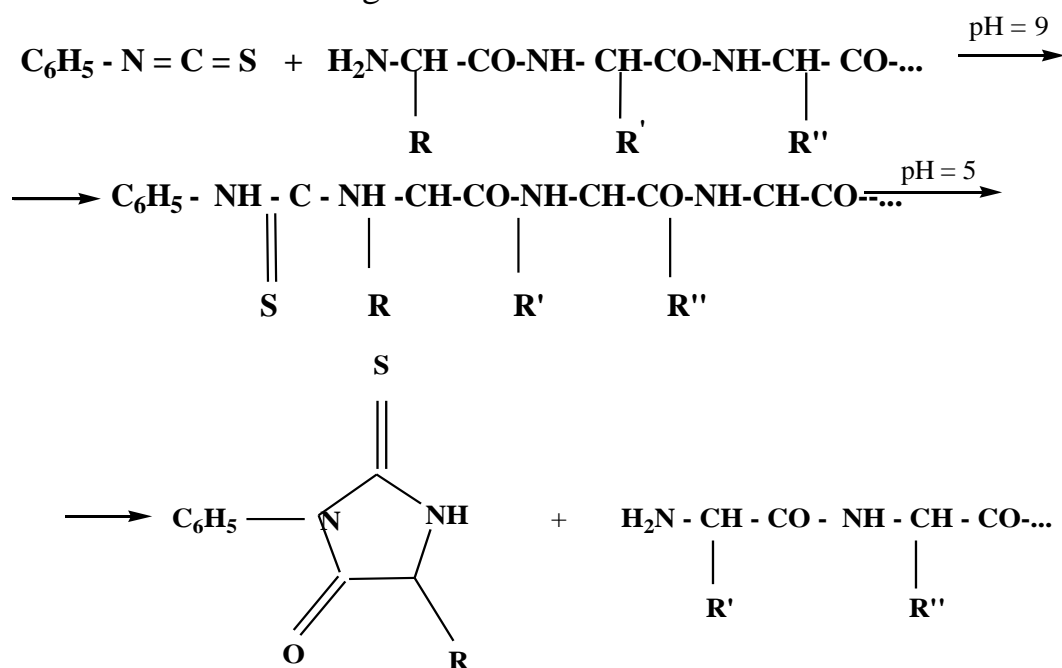

Phenylthiohydantoin derived from the N-terminal amino acid

In the first step, the N-terminal amino acid acts as a nucleophile toward the C=S bond of the reagent to form a thiourea derivative. In the second step, the N-terminal amino acid is removed in the form of a heterocyclic compound, a phenylthiohydantoin. The specific phenylthiohydantoin that is formed can be identified by comparison with reference compounds separately prepared from the known amino acids. Then the two steps are repeated, to identify the next amino acid, and so on. The method has been automated, so currently amino acid 'sequinators' can easily determine, in a day, the sequence of the first 50 or so amino acids in a peptide.

17.2.3. Strategy of Peptide Synthesis

Many methods have been developed to link amino acids in a controlled manner. To link the carboxyl group of an acid to the amino group of a second acid, we must:

- protect an amino group of the first amino acid and the carboxyl group of the second amino acid;
- activate a carboxyl group of the first amino acid.

In this way, we can control the linking of the two amino acids so that the carboxyl group of amino acid-1 combines with the amino acid-2.

For example, synthesis the dipeptide **Gly-Ala** involves five steps.

The first step is the protection of amino group in glycine molecule by acylation with **t-butoxycarbonyl chloride** (BOC):

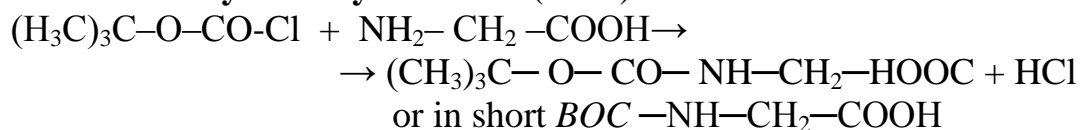

In the second step the carboxylic group Gly molecule undergoes activation; the poor leaving carboxyl group is displaced by a good leaving chloride anion:



In the third step the carboxylic group in in alanine molecule is protected by esterification:

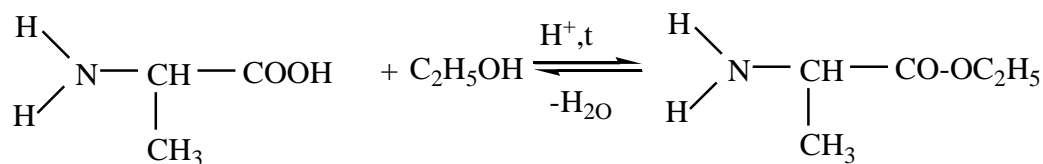

The fourth step is the formation of a peptide bond:

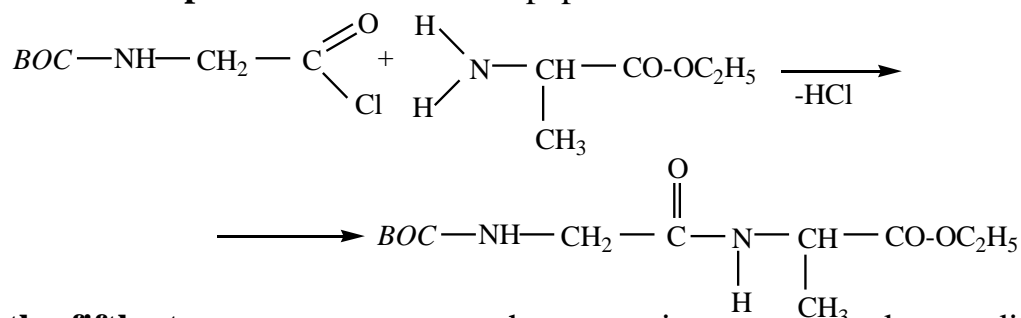

In the fifth step we must remove the protecting groups under conditions that do not hydrolyze the peptide bond. BOC-protection is removed by a mixture of acetic and hydro bromic acids, while ester protection of the carboxyl group is removed by base-catalyzed hydrolysis:

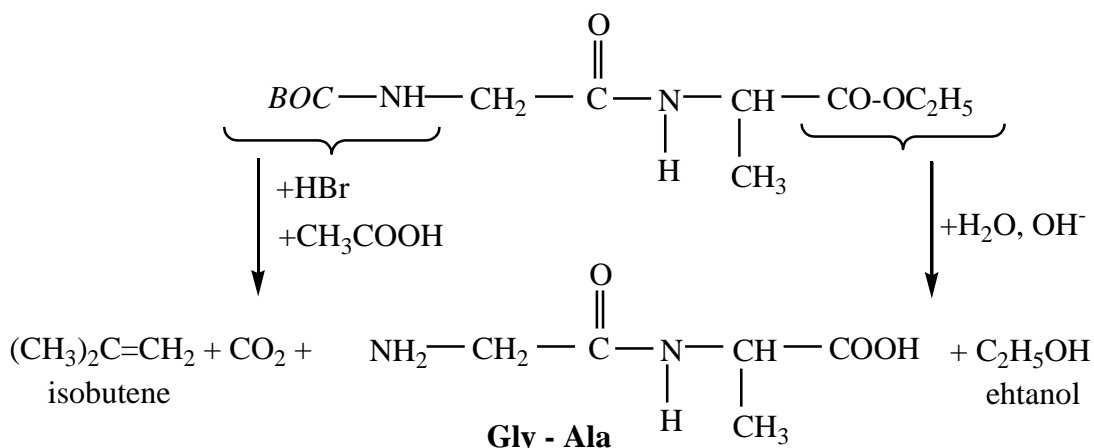

17.2.4. The Spatial Structure of Proteins

Atoms rotation about single bonds in peptide chain is responsible for the possible folding conformations of a polypeptide chain. There are two arrangements that are particularly stable: the alpha helix and the beta sheet. They are defined as **the secondary structure of proteins**.

L. Pauling proposed that the polypeptide chain coils about itself in a spiral manner to form a helix, held rigid by intra chain hydrogen bonds. The α – helix is right-handed and has a pitch of 5.4 Å, or 3.6 amino acid units (Figure 17.6).

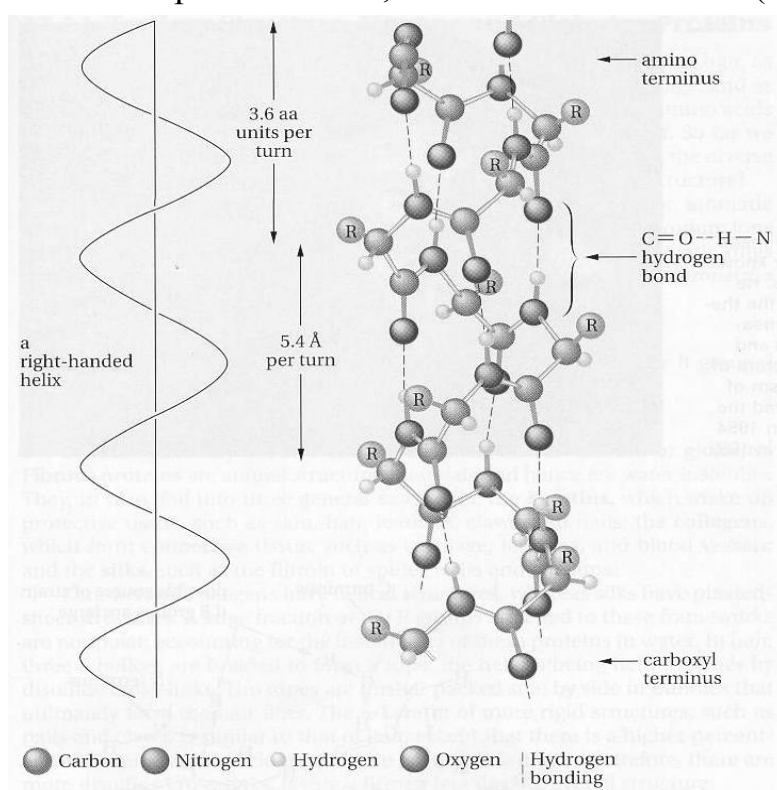
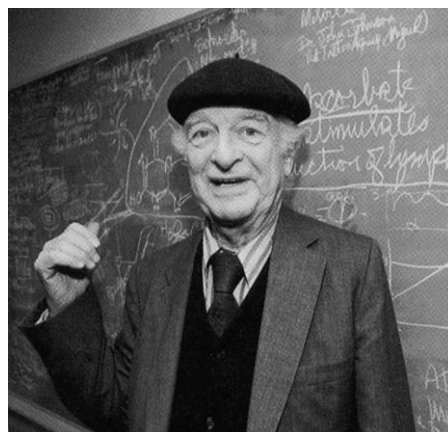

Figure 17.6 — α -Helical structure of a polypeptide chain

Linus Carl Pauling (1901 –1994) was an American chemist, biochemist, peace activist, author, and educator. *New Scientist* reportedly called him one of the 20 greatest scientists of all time. He was one of the founders of quantum chemistry and molecular biology. For his scientific work, Pauling was awarded the Nobel Prize in Chemistry in 1954. In 1962, for his peace activism, he was awarded the Nobel Peace Prize.



α -Helix and β - Sheet are stabilized by hydrogen bonding. Each amino acid is bonded with the fifth amino acid in a chain by a hydrogen bond. For example, in a sequence **Gly – Ala – Phen – Glu – Ser - Ala** glycine is linked with serine (Figure 17.7).

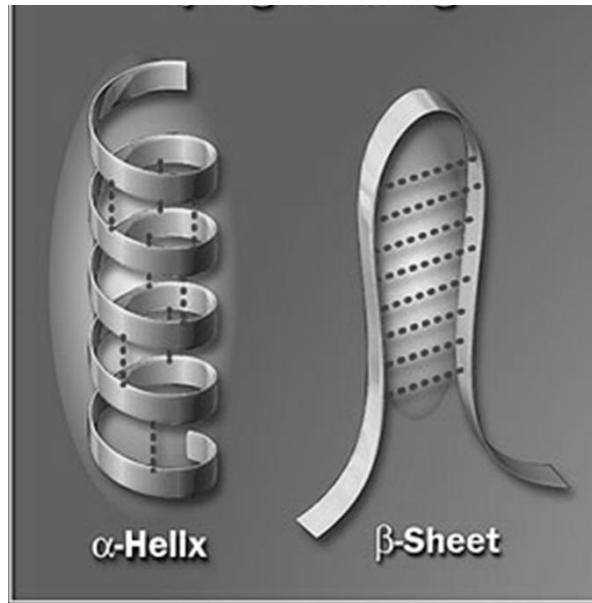

Figure 17.7 — α -Helix and β -Sheet are stabilized by hydrogen bonding

All the hydrogen bonds are roughly aligned with the long axis of the helix. The very large number of hydrogen bonds (one for each amino acid unit) strengthens the helical structure. The radicals of individual amino acid units are directed outward and do not disrupt the central core of the helix.

The term **protein tertiary structure** refers to a protein's geometric shape. The tertiary structure will have a single polypeptide chain "backbone" with one or more protein secondary structures, the protein domains. Amino acid side chains may interact and bond in a number of ways. The interactions and bonds of side chains within a particular protein determine its tertiary structure. The protein tertiary structure is defined by its atomic coordinates. These coordinates may refer either to a protein domain or to the entire tertiary structure. A number of tertiary structures may fold into a quaternary structure.

Proteins generally fall into one of two main classes: **fibrous** or **globular**. Fibrous proteins are animal structural materials and hence are water insoluble. They, in turn, fall into three general categories: **the keratins**, which make up protective tissue, such as skin, hair, feathers, claws, and nails; **the collagens**, which form connective tissue, such as cartilage, tendons, and blood vessels; and **the silks**, such as fibroin of spider webs and cocoons.

Globular proteins are very different from fibrous proteins. They tend to be water soluble and have roughly spherical shapes, as their name suggests. Instead

of being structural, globular proteins perform various other biological functions. They may be enzymes, hormones, transport proteins, or storage proteins. Globular proteins are mainly helical, but they have folds that permit the overall shape to be globular.

Tertiary structure of proteins is stabilized by hydrogen and ionic bonds, by disulfide bridges and hydrophobic interactions (Figure 17.8).

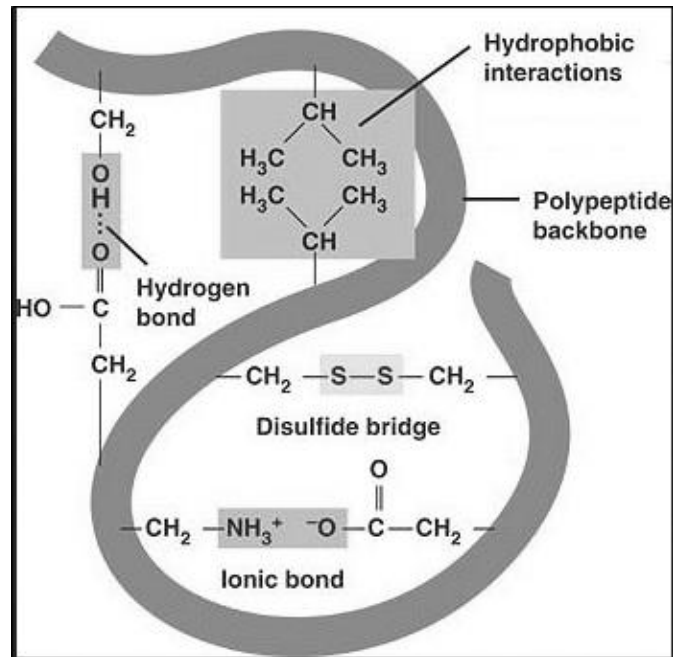

Figure 17.8 — Tertiary structure of proteins

In biochemistry, **quaternary structure** is the number and arrangement of multiple folded protein subunits in a multi-subunit complex. Aggregation helps to keep nonpolar portions of the protein surface from being exposed to the aqueous cellular environment. Hemoglobin, the oxygen-transport protein of red cells, provides an example of such aggregation. It consists of four almost spherical units, two α units with 141 amino acids and two β units with 146 amino acids. The four units come together in a tetrahedral array, as shown in Figure 17.9.

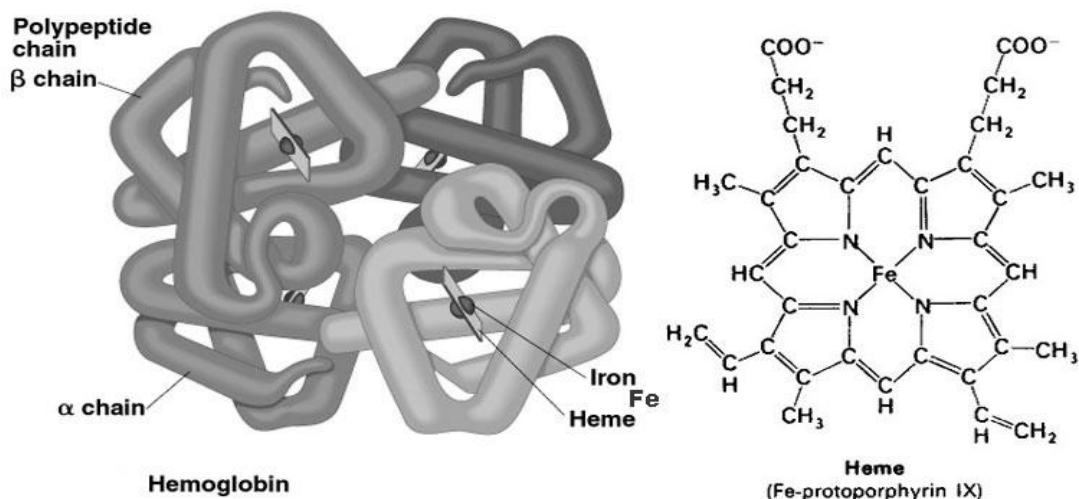
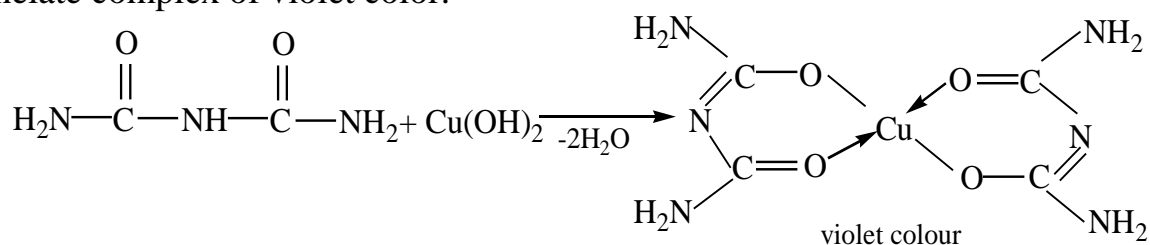

Figure 17.9 — Tertiary structure of hemoglobin

17.2.5. Test Reactions on α -Amino Acids and Proteins

Peculiarities of amino acids and proteins chemistry is the presence of numerous test (color) reaction that in due time were the base of chemical analysis. At present these reactions are used for chromatographic detection of amino acids.

For the detection of the peptide bonds in peptides and proteins **the biuret reaction** is applied, which is running with all peptides and proteins having at least two such bonds. Biuret is the condensation product of two molecules of urea. Its interaction with copper ions in basic medium results in the formation of chelate complex of violet color:



The Ninhydrin Reaction. Ninhydrin is a useful reagent for detecting amino acids and determining the concentration of their solutions. It is a hydrate of a cyclic triketone, and when it reacts with an amino acid, a violet dye is produced. The overall reaction, whose mechanism is complex, is as follows:

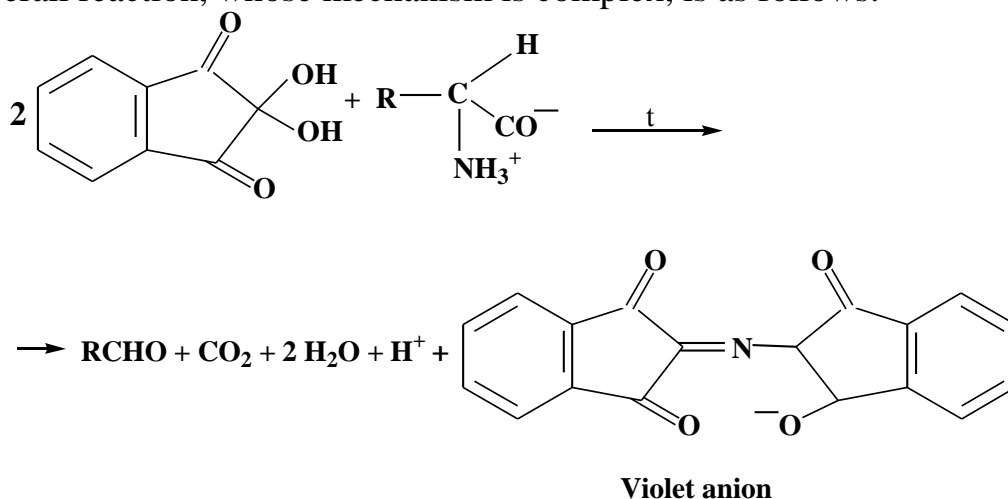

Only the nitrogen atom of the violet dye comes from the amino acid; the rest of the amino acid is converted to an aldehyde and carbon dioxide. Therefore, the same violet dye is produced from all α -amino acids with a primary amino group, and the intensity of its color is directly proportional to the concentration of the amino acid present. Only proline, which has a secondary amino group, reacts differently to give a yellow dye, but this, too, can be used for analysis.

The Xanthoprotenic Reaction is applied to detect aromatic, heterocyclic amino acids and proteins. Their solutions turn yellow when treated with concentrated nitric acid under heating. By adding alkali colour becomes orange due to ionization the phenolic hydroxyl group:

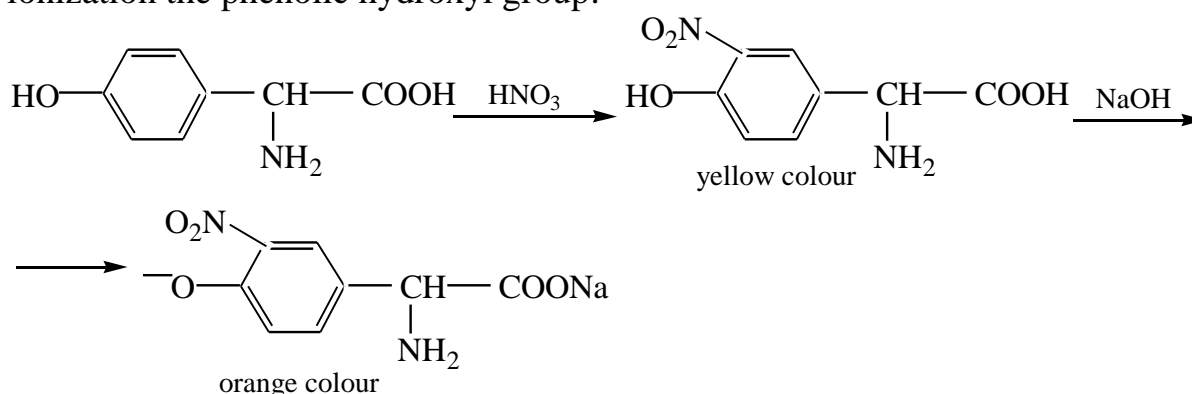

The Phol Reaction is applied to detect sulfur containing amino acids and proteins. The black lead salt precipitates from proteins solutions when they are treated with lead (II) acetate (CH₃COO)₂Pb in basic medium:

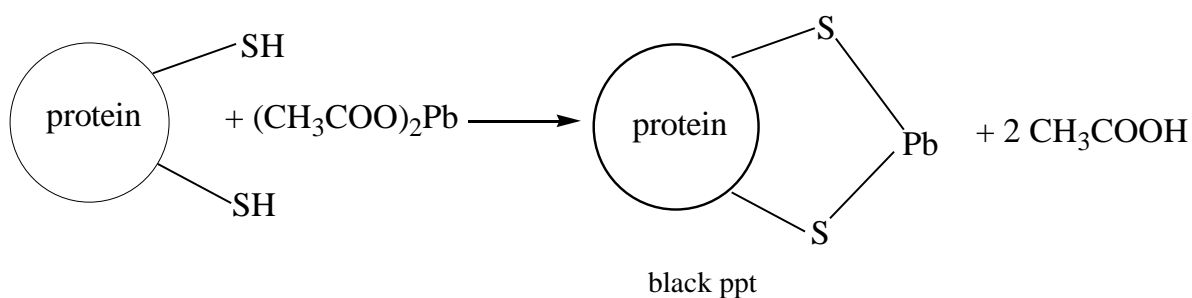

17.3. Laboratory Work

α -AMINO ACIDS, PEPTIDES AND PROTEINS

Test 1. The Ninhydrin reaction

Ninhydrin is a useful reagent for detecting amino acids and determining the concentration of their solutions. It is the hydrate of a cyclic triketone, and when it reacts with an amino acid, a violet dye is produced.

Pour 4 drops of 1 % glycine solution and treat it with 2 drops of 0.1 % ninhydrin solution. Heat the mixture up to the boiling point. What can you see? Write the equation of ninhydrin reaction.

Test 2. Oxidative Deamination of α -Amino Acids with Nitrous Acid (Van-Slake Method)

Pour 5 drops of 1 % glycine solution into a test tube and treat it with equal volume of 5 % of sodium nitrite solution. Then add 2 drops of concentrated sulfuric acid and stir a prepared solution. What can you see? Write an equation for the reaction of glycine with nitrous acid.

Test 3. The Formation of Copper (II) Complex Salt with Glycine

Pour 1 ml of 1 % glycine solution into a test tube and treat it with some crystals of dry copper (II) carbonate salt. Heat the mixture up to the boiling point. What can you see? Write an equation for the performed reaction.

Test 4. The Biuretic Test on Peptide Bonds

Pour 5–6 drops of egg protein solution into a test tube and treat it with the equal volume of 10 % sodium hydroxide solution. After that, add 1–2 drops of copper (II) sulfate solution to the prepared mixture. What can you see? Write an equation for the performed reaction.

Test 5. The Xanthoprotenic Reaction

Pour 10 drops of egg protein solution into a test tube and treat it with 2 drops of concentrated nitric acid. Heat a prepared mixture. What can you see? Write an equation for the performed reaction.

Test 6. The Phol Reaction

This reaction occurs due to sulfur containing amino acids present in proteins. Pour 10 drops of egg protein solution into a test tube and treat it with 20 drops of 10% sodium hydroxide solution. Heat a prepared mixture up to the boiling point. Treat the solution with 5 drops of 10 % lead (II) acetate solution. What can you see? Write the equation of the Phol reaction.

17.4. Exercises for the Self-Control

1. Draw the Fischer projections for leucine enantiomers. Name them. Is leucine essential or nonessential amino acid?
2. Illustrate the amphoteric nature of methionine by writing equations for its reactions with one equivalent of:
 - a) hydrochloric acid;
 - b) sodium hydroxide.

3. Write an equation for the serine reaction with formaldehyde. For what purpose this reaction is used in a biochemical analyses?
4. Write an equation for the reaction of phenylalanine transamination with α -ketoglutaric acid. Name the products. What enzyme and coenzyme are involved in this process?
5. Write the equation for the reductive amination that produces glutamic acid. What coenzyme is involved in this process?
6. Write out the scheme for tryptophan decarboxylation. Under what conditions it may occurs in vivo and in vitro?
7. Write the structure for glycylglycine, and show the resonance contributors to the peptide bond. At which bond is rotation restricted?
8. Write the structural formula for the tripeptide Phe – Tyr – Thr. Mark peptide bonds and point out N- and C-terminal ends. At approximately what pH will the isoelectric point come?
9. Write the structural formula for the tripeptide Cys –Ser –Ala. Mark peptide bonds and point out N – and C –terminal ends. At approximately what pH will the isoelectric point come?
10. Write the structural formula for the tripeptide Gly – Glu –Val. Mark peptide bonds and point out N- and C-terminal ends. At approximately what pH will the isoelectric point come?
11. Write out an equation for alanine amino group protection by *t*-butoxycarbonyl chloride. Name the mechanism of this reaction.
12. Name the test reaction on the peptide bond. Write out an equation of it. What is the colour of the prepared solution?
13. Write an equation for the hydrolysis of
 - a) leucylserine;
 - b) valyltyrosylmethionine.

CHAPTER 18

NUCLEOTIDES AND NUCLEIC ACIDS

After reading this chapter, you should be able to:

- define general structure of nucleic acids;
- describe structure and tautomerism of the pyrimidines and the purines;
- discuss structure, nomenclature and properties of nucleosides and nucleotides;
- explain the primary and secondary structure of DNA;
- summarize structure, chemical properties and biological functions of ATP.

In this chapter, we will describe the structure of the nucleic acids, DNA and RNA. We will first look at their building blocks, the nucleosides and nucleotides, and then describe how these building blocks are linked to form giant

nucleic acid molecules. Later we will consider the three-dimensional structures of these vital biopolymers as well as the structure and properties of the coenzyme NAD and high-energy ATP molecules.

18.1. The General Structure of Nucleic Acids

Nucleic acids are biopolymers, which are responsible for storing and transmitting genetic information from one generation to another.

They form linear, chainlike macromolecules that were first isolated from cell nuclei. Nucleic acids are found in all living cells and viruses. The most common nucleic acids are **deoxyribonucleic acid (DNA)** and **ribonucleic acid (RNA)**.

DNA was first identified in 1868 by Friedrich Miescher, a Swiss biologist, in the nuclei of pus cells obtained from discarded surgical bandages. He called the substance nuclein, noted the presence of phosphorous, and separated the substance into a basic part (which we now know is DNA) and an acidic part (a class of acidic proteins that bind to basic DNA).

The macromolecules of nucleic acids are built up of mononucleotides (Figure 18.1):

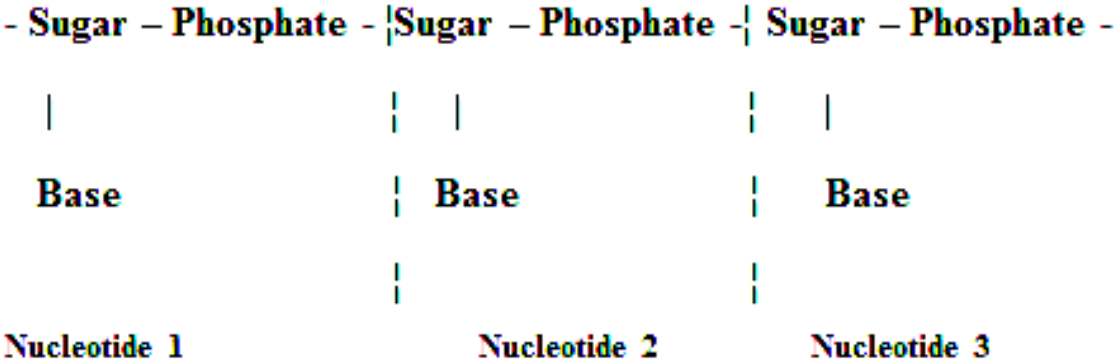
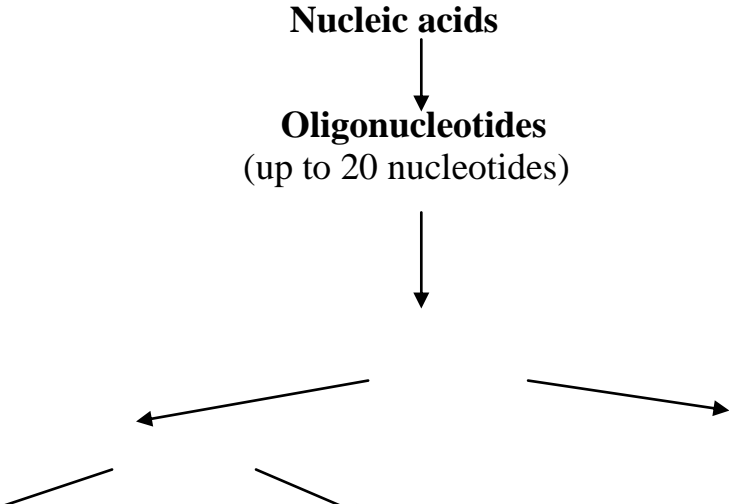

Figure 18.1 — Schematic structure of a nucleic acid

Each mononucleotide is composed of a pentose sugar, phosphate and a heterocyclic base. Heterocyclic bases are responsible for storing and transmitting genetic information while sugars and phosphates fulfill a structural function.

Hydrolysis of nucleic acids gives a complete description of their primary structure and structural units.



Mononucleotides
(structural units of nucleic acids)

Nucleosides

H₃PO₄

DNA and RNA differ in sugars and heterocyclic bases.

According to the obtained data Nucleic acids are defined as macromolecules built up from mononucleotides linked to form giant molecules.

The heterocyclic bases fall into two categories:

- the purines (adenine – A; guanine – G).
- the pyrimidines (uracil – U; thymine – T; cytosine – C).

The purines bases

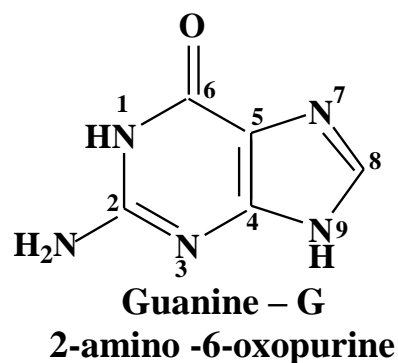
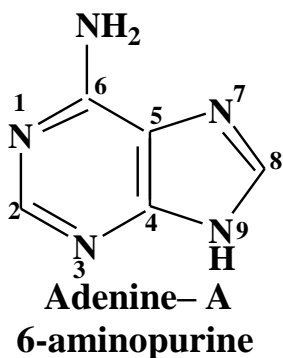

The pyrimidines bases

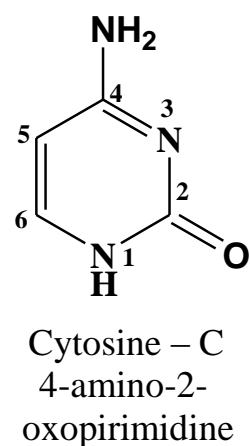
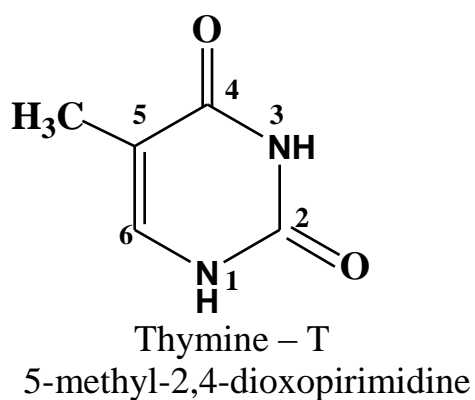
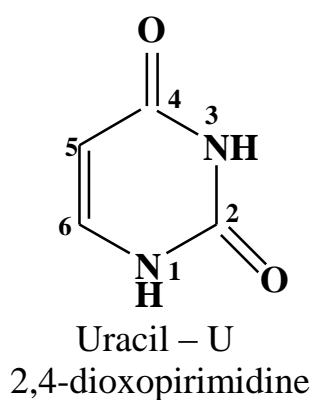

They all are aromatic systems, which can exist in lactam and lactime forms simultaneously (the phenomenon of lactam-lactime tautomerism). But only their lactam forms present in nucleic acids due to their higher stability.

Lactam–lactime tautomerism

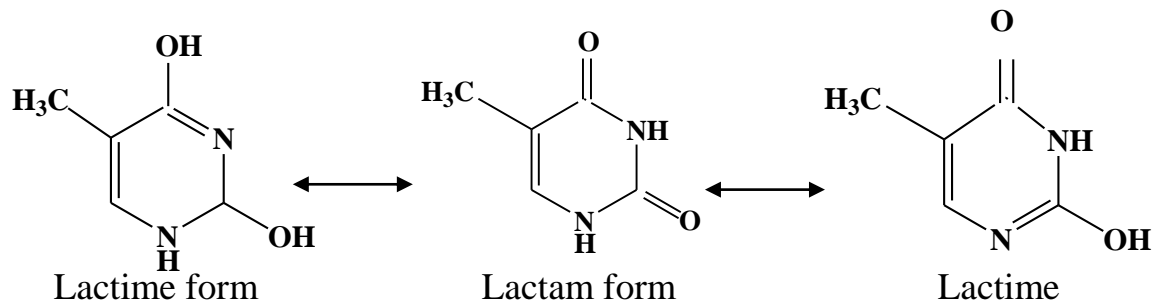

The purines exhibit prototropic tautomerism (the reversible proton migration from N-9 to N-7). But still NH -9 isomers are components of nucleic acids.

Prototropic tautomerism

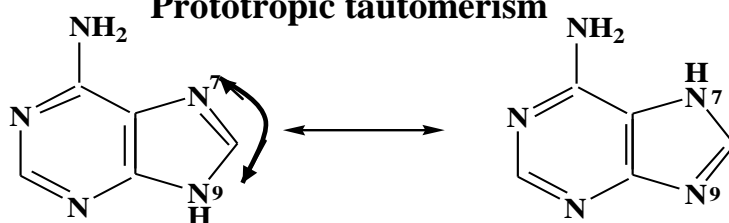

Pentoses are involved in nucleic acids in their cyclic forms with β -configuration of anomeric carbon atom:

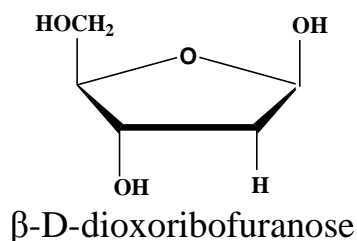
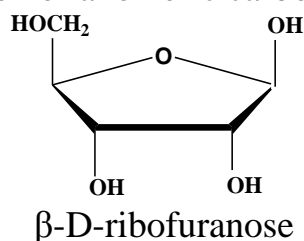

18.2. Nucleosides

Nucleosides are N-glycosides, in which the pyrimidine or purine base is connected to the anomeric carbon (C'-1) of the sugar. The pyrimidines are connected at N-1 and the purines at N-9. N-glycosides have structures similar to those of O-glycosides. For example:

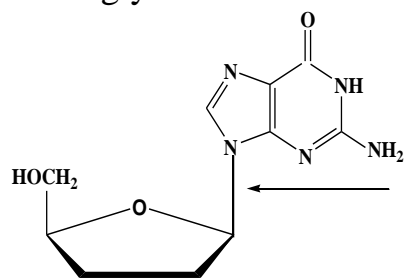

Deoxyguanosine

9- β -D-deoxyribofuranosyl guanine

N-glycosidic bond

OH

Ending *osine* is typical for purine nucleosides.

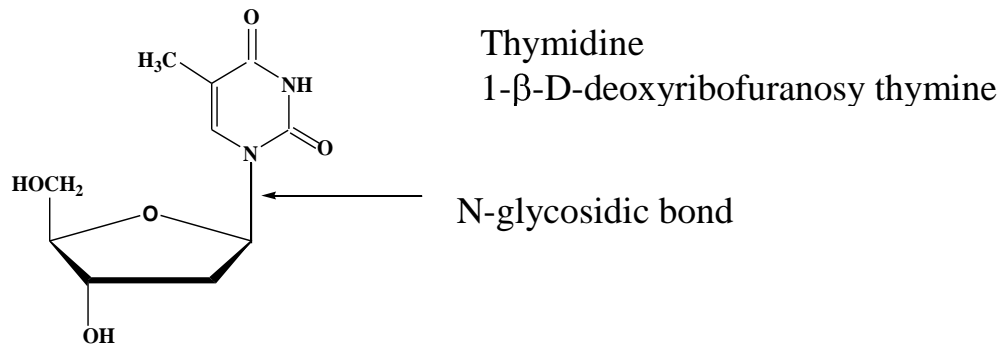

Ending *idine* is typical for pyrimidine nucleosides. Prefix deoxy is used for nucleosides, containing deoxyribose.

Nucleosides fall into two categories:

- Purines;
- Pyrimidines.

18.3. Mononucleotides

Nucleotides are phosphate esters of nucleosides. A hydroxyl group in the sugar part of a nucleoside is esterified with phosphoric acid either at 5' or the 3'-positions. Nucleotides are found primarily as the monomeric units of nucleic acids, however, they also are required for numerous other important functions within the cell.

Nucleotides fall into two categories:

- Ribonucleotides.
- Deoxyribonucleotides.

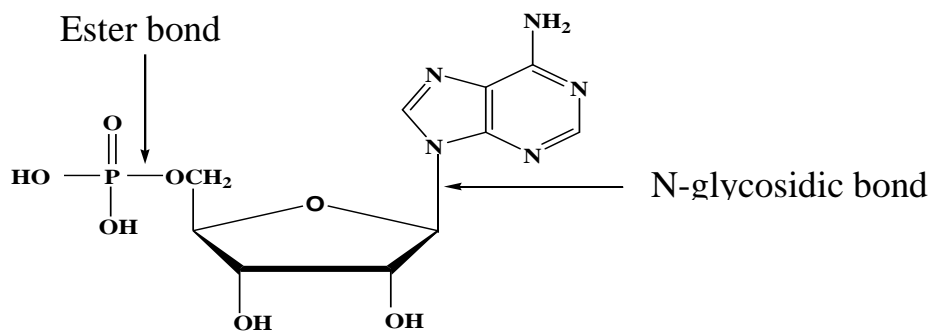

Adenosine-5'-monophosphate AMP

Mononucleotides are rather strong acids and exist as anions at physiological pH values (pH = 7.35).

Mononucleotides undergo partial hydrolysis in basic and weak acidic media and complete hydrolysis in strong acidic medium (pH = 1). They also may undergo enzymatic hydrolysis.

A scheme of AMP hydrolysis

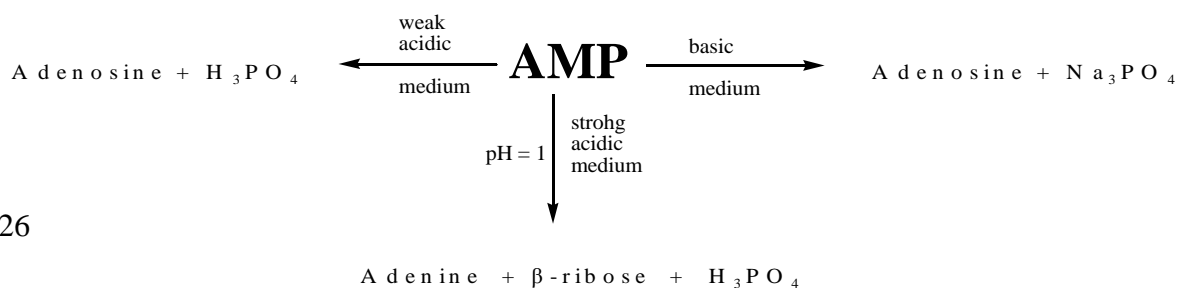

In cyclic mononucleotides both 5' and 3' hydroxyl groups are acylated with phosphoric acid. Such compounds serve as mediators of numerous important cellular processes such as second messengers in signal transduction events. The predominant second messenger is cyclic AMP (camp).

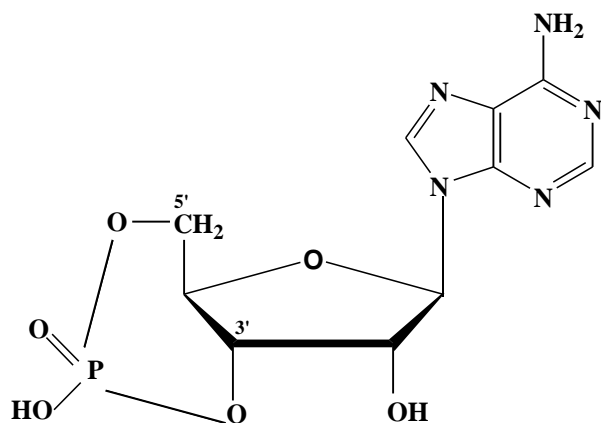

Adenosine -3'-5'-cyclic monophosphate c-AMP

18.4. Primary and Secondary Structure of Nucleic Acids

The primary structure of nucleic acids is the sequence of mononucleotide units linked through phosphodiester bonds. The 3' hydroxyl of the one pentose sugar is linked to the 5' hydroxyl of the next ribose or deoxyribose unit by a **phosphodiester bond**. The heterocyclic base is connected to the anomeric carbon of each ribose (deoxyribose) by a β -N-glycosidic bond. Figure 18.2 shows a schematic drawing of a DNA segment and Figure 18.3 — a schematic drawing of a RNA segment.

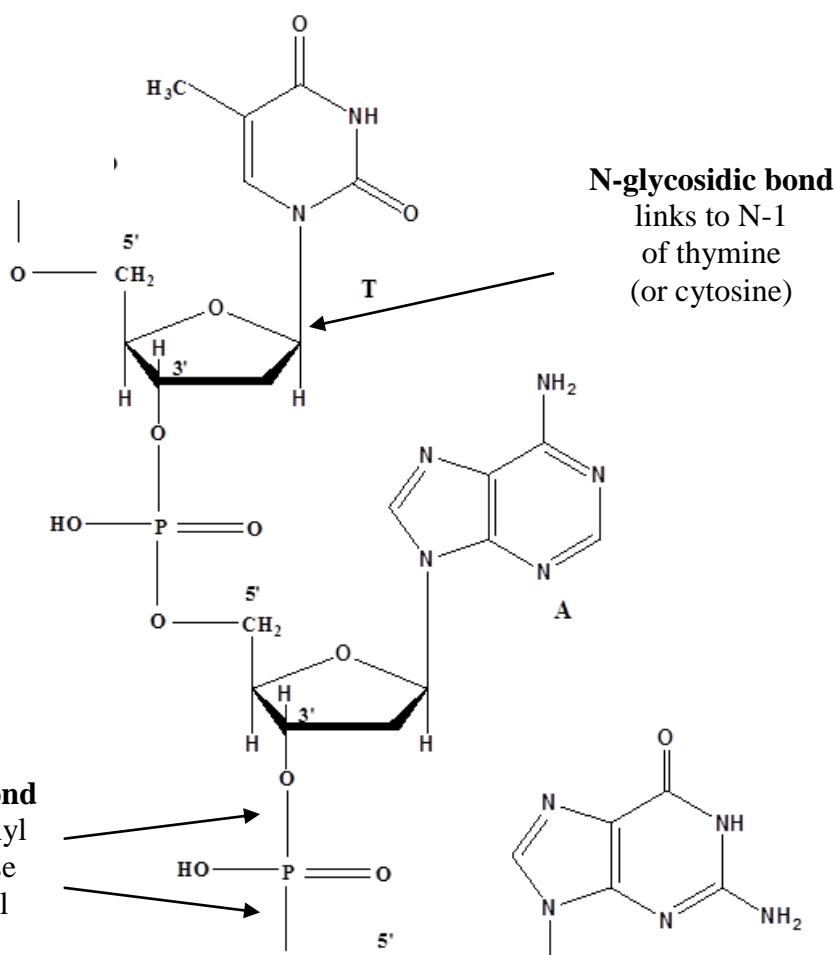

N-glycosidic bond links to N-1 of thymine (or cytosine)

Phosphodiester bond links the 3' hydroxyl of one deoxyribose to the 5' hydroxyl of the next

Figure 18.2 — A segment of DNA chain

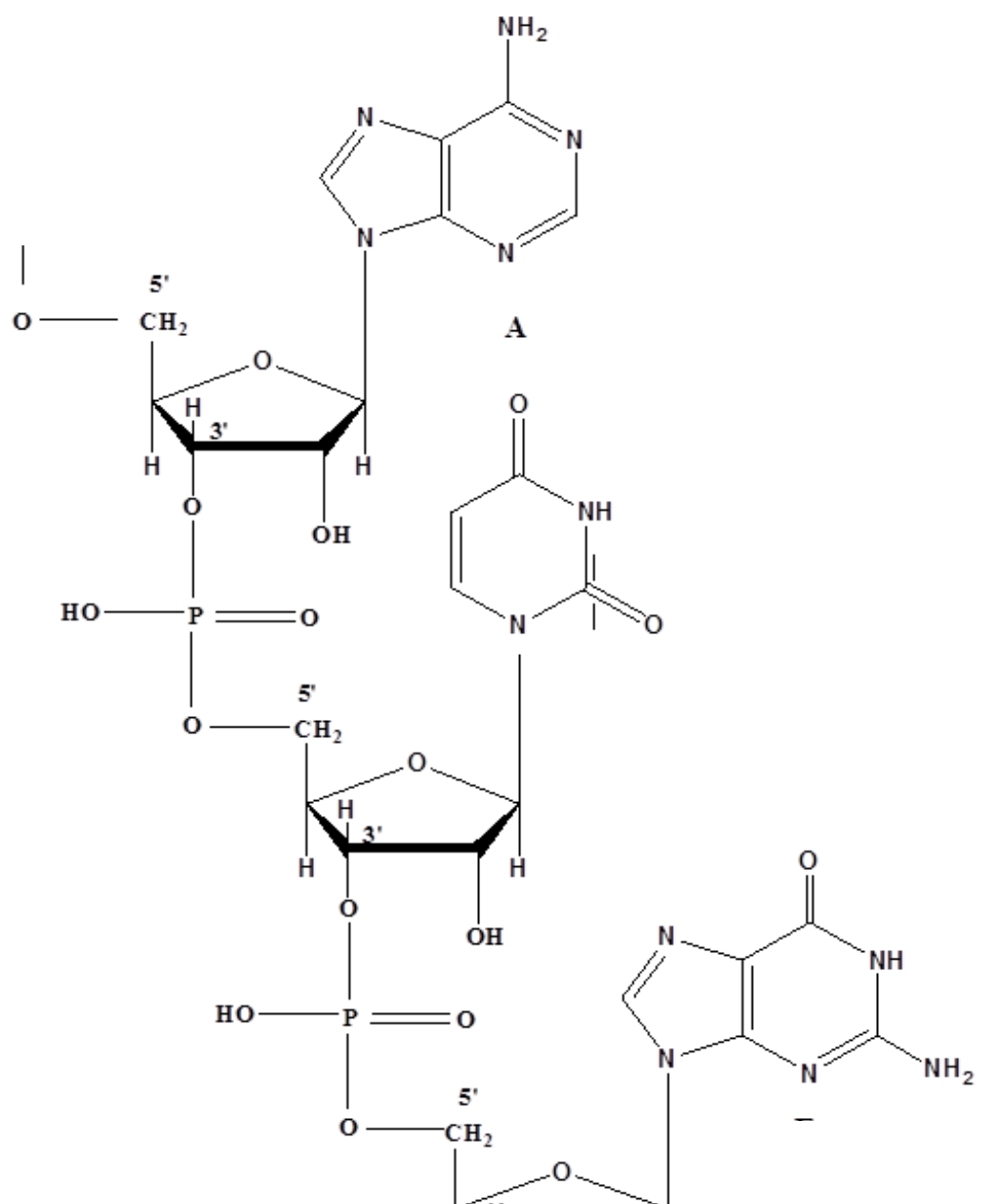

Figure 18.3 — A segment of RNA chain

It has been known since 1938 that DNA molecules have a discrete shape, because X-ray studies of DNA threads showed a regular stacking pattern with some periodicity. A key observation by E. Chargaff (Columbia University) in 1950 provided an important clue to the structure. Chargaff analyzed the base content of DNA from many different organisms and found that the amounts of **A** and **T** are always equal and the amounts of **G** and **C** are always equal. For example, human DNA contains about 30 % each of **A** and **T** and 20 % each of **G** and **C**. Other DNA sources give different percentages, but the ratios of A to T and of G to C are always unity.

The meaning of these equivalences was not evident until 1953, when Watson and Crick, working together in Cambridge, England, proposed the double helix model for DNA. The important features of their model follow:

1. DNA consists of two helical polynucleotide chains around a common axis.
2. The helices are right-handed, and the two strands run in opposite directions with regard to their 3' and 5' ends.
3. The purine and pyrimidine bases lie inside the helix, in planes perpendicular to the helical axis; the deoxyribose and phosphate groups form the outside of the helix.
4. The two chains are held together by purine-pyrimidine base pairs connected by hydrogen bonds. Adenine is always paired with thymine, and guanine is always paired with cytosine.
5. The diameter of the helix is 2 nm. Adjacent base pairs are separated by 0.34 nm and oriented through a helical rotation of 360°. There are therefore 10 base pairs for every turn of the helix (360°), and the structure repeats every 3.4 nm.

6. There is no restriction on the sequence of bases along a polynucleotide chain. The exact sequence carries the genetic information.

Figure 18.4 shows schematic models of the double helix. The key feature of the structure is the complementarity of the base pairing: A—T and G—C.

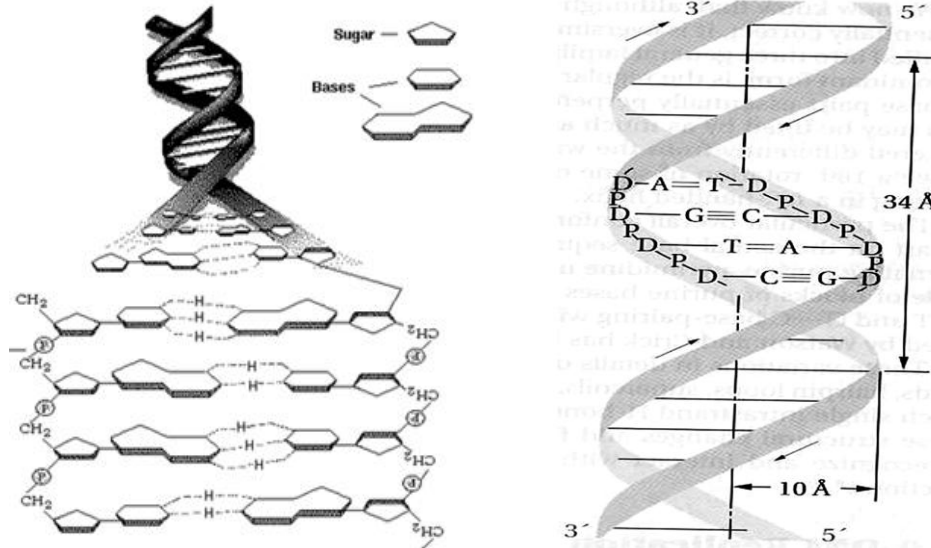
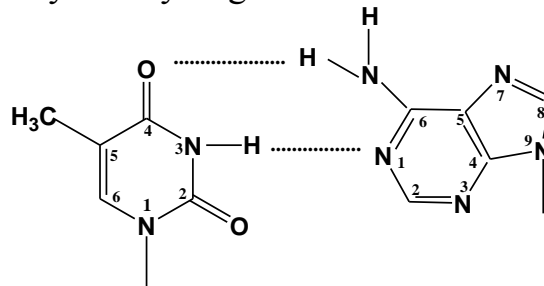
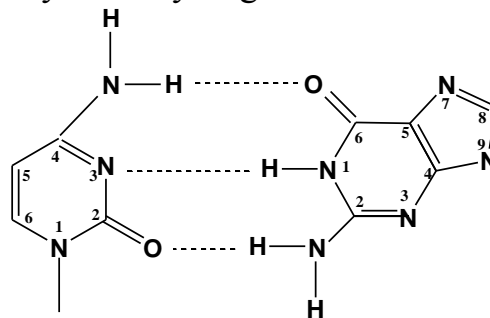

Figure 18.4 — Model and schematic representations of the DNA double helix
The A—T pair is joined by two hydrogen bonds:



The G—C pair is joined by three hydrogen bonds:



James Dewey Watson (born 1928), an American molecular biologist, and Francis Harry Compton Crick (1916–2004), a British molecular biologist, are the co-discoverers of the DNA secondary structure. In 1962 they were awarded the Nobel Prize in Physiology



and Medicine "for their discoveries concerning the molecular structure of nucleic acids and its significance for information transfer in living material".



DNA and Crime

DNA profiling, sometimes called DNA fingerprinting, is one of the most powerful new techniques of forensic science. Here's how it works.

A small quantity of DNA is obtained from some source associated with a crime — semen, blood, or hair roots, perhaps associated with a rape, murder, or other violent crime. The DNA is purified, cut with established restriction enzymes, and sequenced as described in Section 18.6. Functional genes those that code for enzymes, hormones, and other peptides common to all humans — do not vary from person to person, but these genes account for only about 5 % of human DNA. The remaining DNA varies enormously from person to person, and in fact (except for identical twins) is characteristic of the individual. The DNA in these genes can identify a single person. And one tremendous advantage of the method is that the DNA sample can be very small, as small as a few micrograms.

There are two main uses of DNA profiling in dealing with a crime. One is to compare a suspect's profile with a sample from the scene of the crime. A few years ago, in one of the first applications of the DNA technique, this individual suspected of two murders and

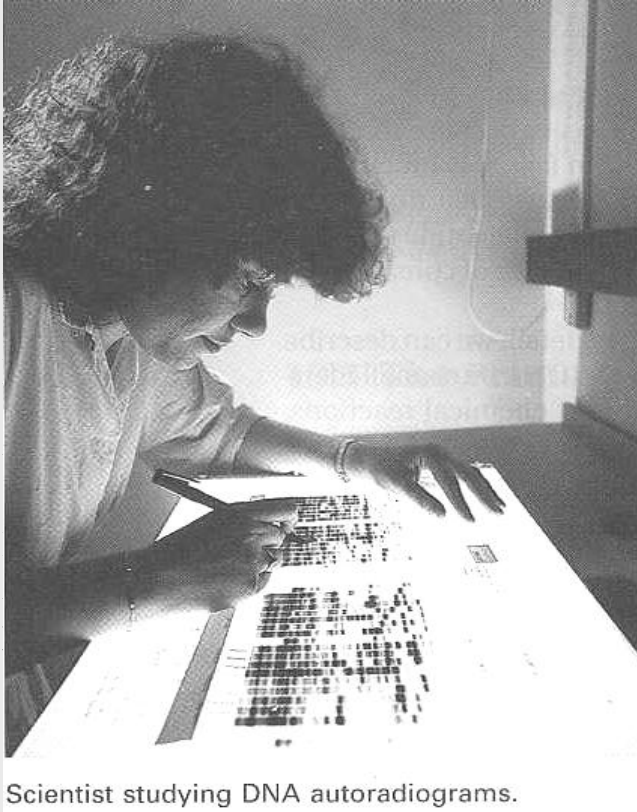

Scientist studying DNA autoradiograms.

potential for use in crime investigation, similar to those used for fingerprint-base should answer such questions up with one from a previous crime? on file?

Forensic science is not restricted to humans. A hair from a cat named Snowball, linked her owner to the victim, ultimately owner.

DNA profiling, it isn't without prob-rial in 1989 identified some of them. g must be done carefully and with %, especially with band shifting, when aster or slower than another.

When comparing patterns from two DNA samples, it is essential to show that the bands match in order to conclude that the samples come from the same individual. When the job is done properly and a match is obtained, the odds for identity are very long indeed — usually better than one in a hundred million. But in their zeal to apply the method, some firms have been less careful than neces-

18.5. Nicotinamide Adenine Dinucleotide (NAD)

Adenine nucleotides form a portion of several important coenzymes such as NAD, NADP, FAD and coenzyme A. Nicotinamide adenine dinucleotide (NAD) is a coenzyme found in all living cells. The compound is a dinucleotide, because it consists of two nucleotides joined through their phosphate groups. One nucleotide contains an adenine base and the other nicotinamide.

In metabolism, nicotinamide adenine dinucleotide is involved in redox reactions, carrying electrons from one substrate to another. The coenzyme is, therefore, found in two forms in cells: NAD^+ is an oxidizing agent – it accepts electrons from other molecules and becomes reduced. This reaction forms $\text{NAD}\cdot\text{H}$, which can then be used as a reducing agent to donate electrons. The structural formulas of NAD^+ and $\text{NAD}\cdot\text{H}$ are shown in Figures 18.5 and 18.6.

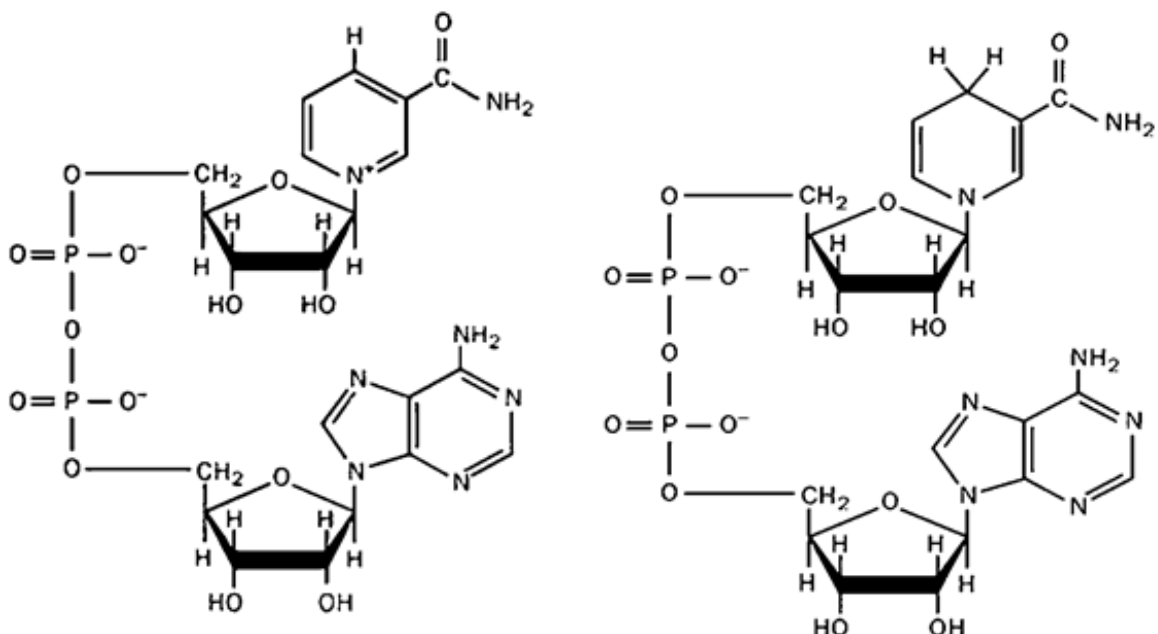
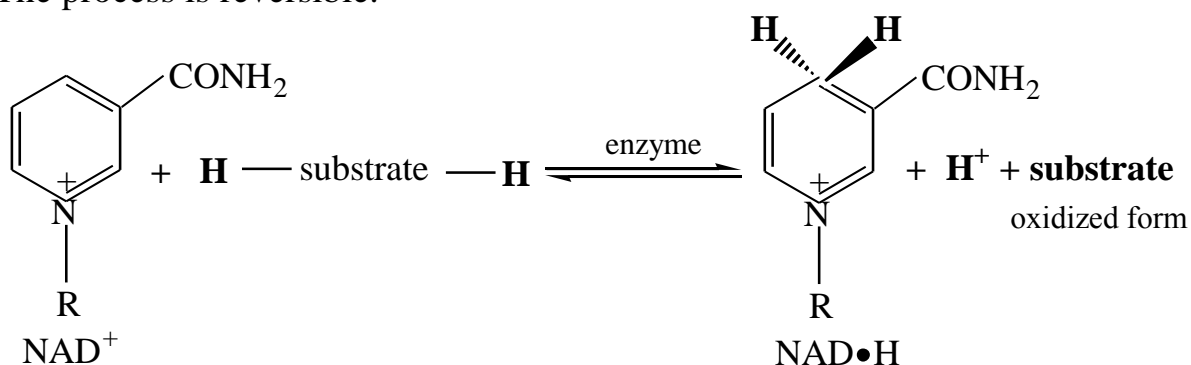

Figure 18.5 — The structure of NAD^+

Figure 18.6 — The structure of $\text{NAD}\cdot\text{H}$

NAD is a coenzyme that dehydrogenates alcohols to aldehydes or ketones, or the reverse process: it reduces carbonyl groups to alcohols. In biological dehydration, which is a special case of oxidation process, the substrate loses two hydrogen atoms, i.e., two protons and two electrons (2H^+ , 2e^-) or a proton and a hydride ion (H^+ and H^-). Coenzyme NAD^+ is generally regarded as a hydride ion acceptor, although not finally determined whether the transfer of a hydrogen atom to the coenzyme runs simultaneously with electron transfer, or these processes proceed separately. As a result of hydride-ion attachment to the a pyridine ring of coenzyme NAD^+ it turns into 1,4-dihydropyridine fragment. The process is reversible.



These hydride ion transfer reactions are the main function of NAD . For example, oxidation of lactic acid into pyruvic acid, or oxidation of ethyl alcohol into acetaldehyde:

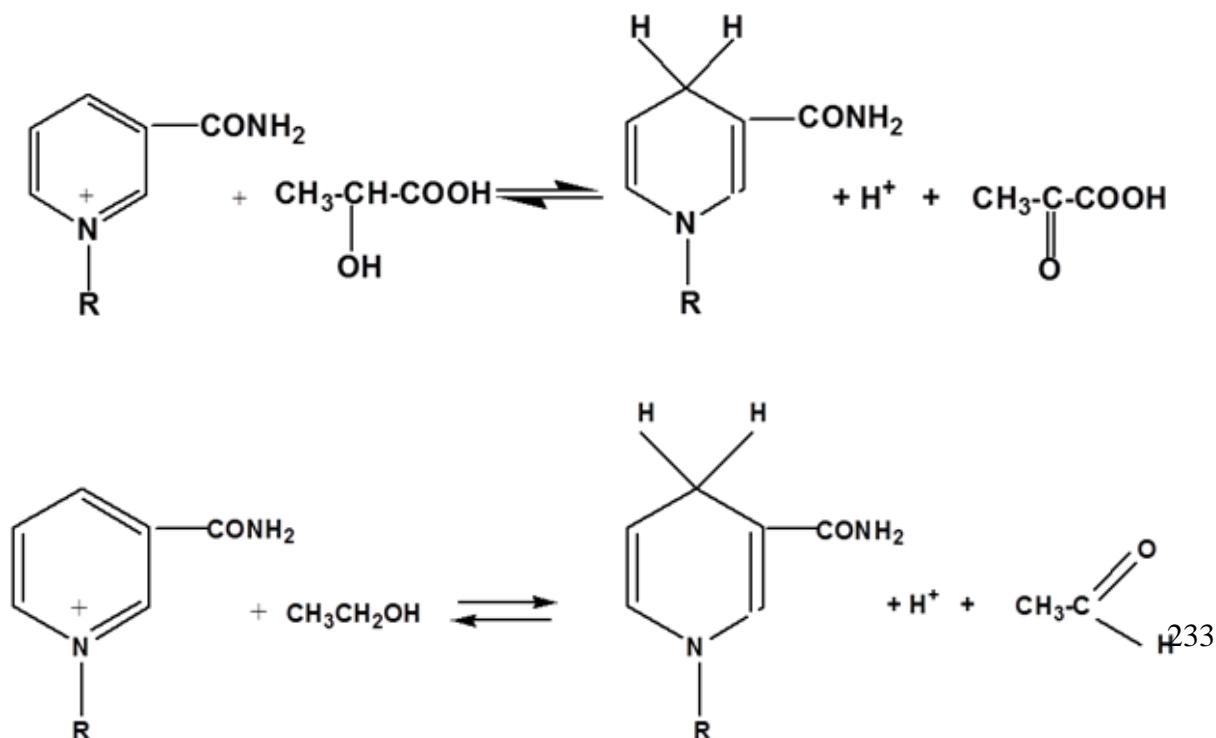

NAD is also used in other cellular processes, the most notable one being a substrate of enzymes that add or remove chemical groups from proteins, in post-translational modifications. Because of the importance of these functions, the enzymes involved in NAD metabolism are targets for drug discovery.

Vitamin B₁₂ (cyanocobalamin), which is essential for the maturation and development of red blood cells, is an incredibly complex molecule that includes a nucleotide as part of its structure (Figure 18.7). Molecule has a central cobalt atom surrounded by a macrocyclic molecule containing four nitrogens, similar to a porphyrin. The cobalt has two additional ligands attached to it, above and below the mean plane of the nitrogen-containing rings. One of these ligands is a ribonucleotide of the unusual base, 5,6-dimethylbenzimidazole. The other ligand is a cyanide group in the vitamin and a 5,6-deoxyadenosyl group in the coenzyme. In each case, there is a direct carbon-cobalt bond. The reactions catalyzed by coenzyme B₁₂ usually involve replacement of Co-R group by a Co-H group.

Vitamin B₁₂, which is produced by certain microorganisms, cannot be synthesized by humans and must be ingested. Only minute amounts are required, but pernicious anemia can result from its deficiency.

Vitamin B₁₂, with its remarkable array of functionality and chirality, is one of the most complex molecules ever to have been created in an organic laboratory. Its synthesis was completed in 1973 by R. B. Woodward (1917–1979), A. Eschenmoser and their students.

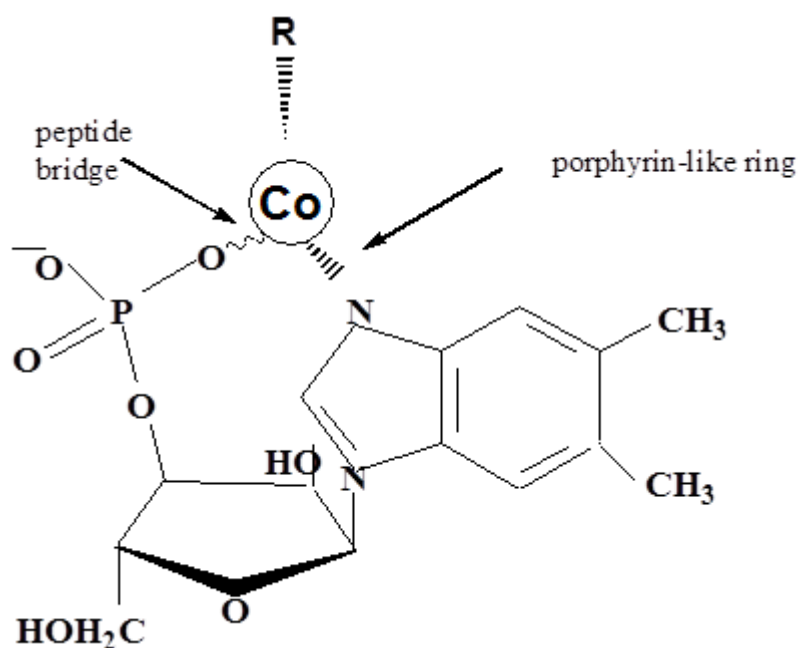
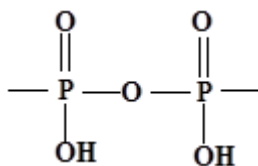

Figure 18.7 — Schematic representation of vitamin B12

18.6. ATP

Adenosine triphosphate (ATP) is a high — energy triphosphate ester used in living systems to provide chemical energy for metabolic needs. ATP accumulates energy, which is released in the process of carbohydrates and lipids oxidation. It contains two macroergetic anhydride bonds:



ATP accumulates energy which is released at the result of carbohydrates and lipids oxidation in vivo.

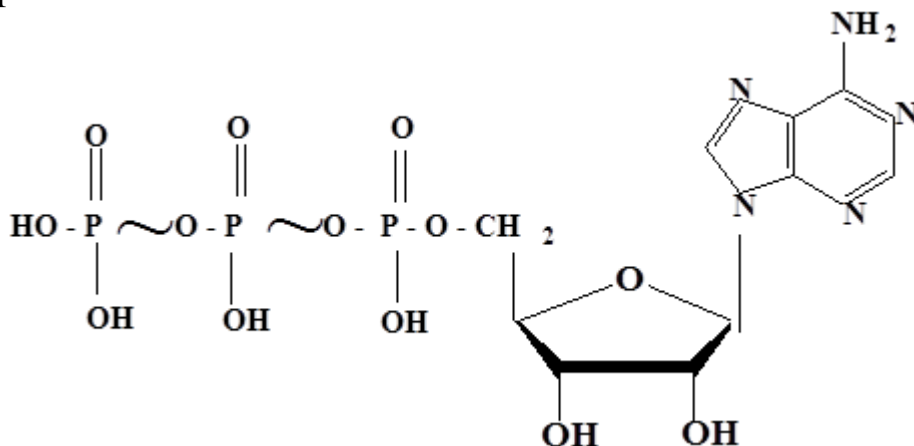

ATP contains two phosphoric anhydride bonds and considerable energy is released when ATP is hydrolyzed to ADP and further to AMP. ATP hydrolysis is an extremely crucial reaction for the supplying of energy for life processes. Just the cutting of one bond is sufficient to liberate about 32 kJ/mol. The scheme of ATP stepwise hydrolysis is given below:

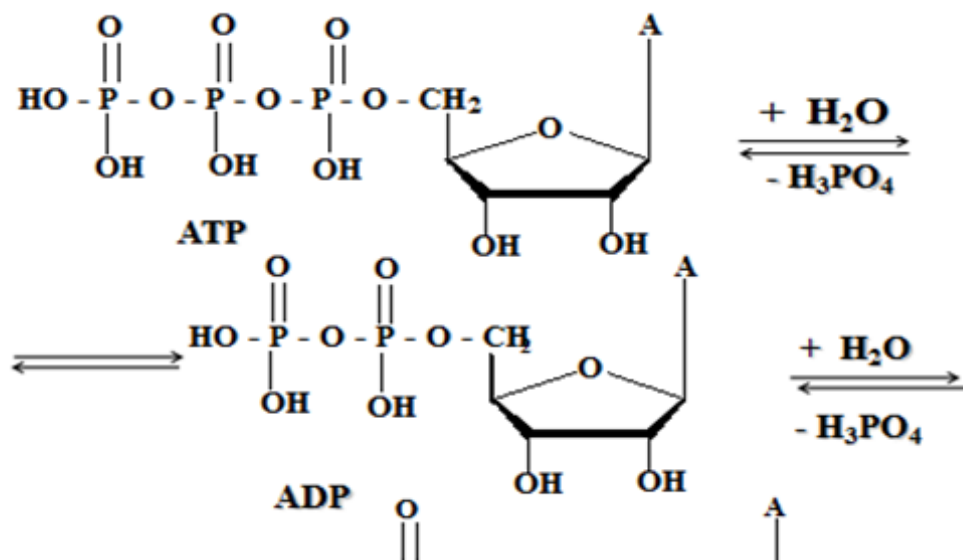

The total quantity of ATP in the human body is about 0.1 moles. The energy used by human cells requires the hydrolysis of 200 to 300 moles of ATP daily. This means that each ATP molecule is recycled 2000 to 3000 times during a single day.

ATP activates α -amino acids, which is prior to proteins' biosynthesis. This activation is the result of ATP interaction with amino acids. The equation of the reaction of ATP interaction with alanine is shown below:

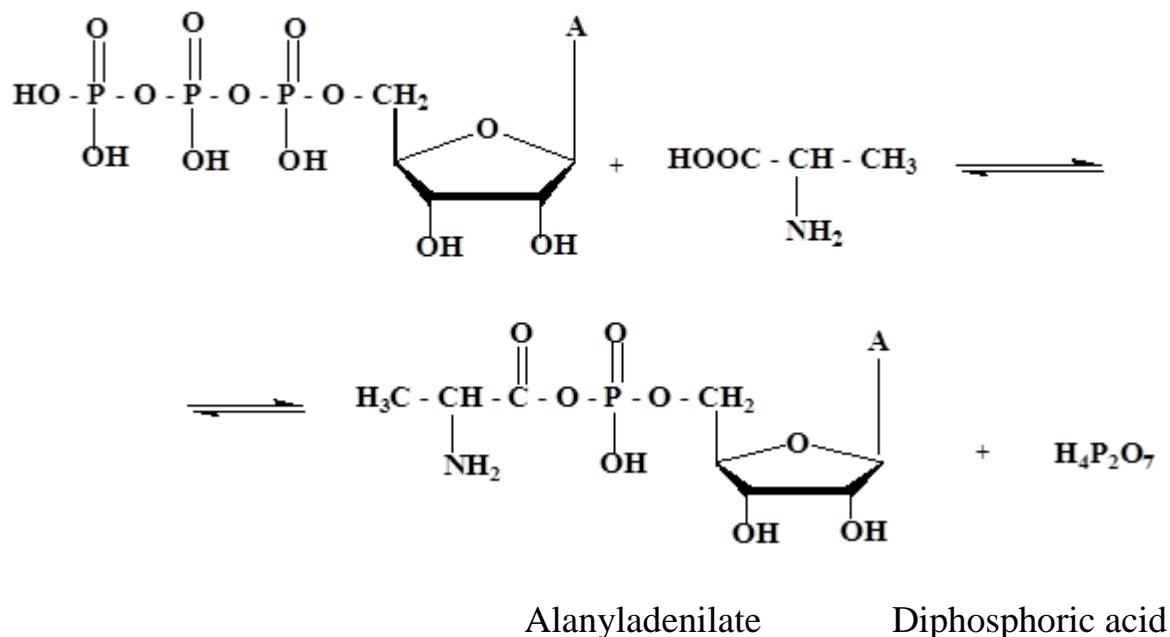

The central role of ATP in energy metabolism was discovered by Fritz Albert Lipmann and Herman Kalckar in 1941.

18.7. Exercises for the Self-Control

1. Describe lactam-lactime and prototropic tautomerism of guanine.
2. Draw the structure of thymidine-5'-monophosphate and write an equation for its in base-catalyzed hydrolysis. Name the products.

3. The products of acid-catalyzed hydrolysis of a mononucleotide are: phosphoric acid, deoxyribose and guanine. Write possible structural formulas for a mononucleotide and name them. Mark N-glycosidic and ester bonds.

4. Draw the structure for c-AMP. Define its biological functions.

5. Draw the full structure of the RNA trinucleotide A-U-G (written from 5' to 3'-end).

6. Draw the full structure of the DNA trinucleotide A-T-C (written from 5' to 3'-end).

7. Write out an equation for ATP reaction with:

a) serine;

b) methionine.

CLOSSARY

A

Acid anhydrides. Carboxylic acid derivatives formed by condensing two carboxylic acid molecules with elimination of a molecule of water.

Acidity constant (K_a). A quantitative measures of the strength of an acid; the greater K_a , the greater the acid strength.

Activating groups. Substituents that, when on a benzene ring, increase the rate of electrophilic aromatic reactions relative to benzene — for example, alkyl, alkoxy, and amino.

Acyclic compound(s). There are compounds that contain no rings.

Acyl group. The group is RCO—.

Acyl halides. A carboxylic acid derivative in which the — OH group is replaced by a halogen atom.

Addition reaction(s). A reaction in which a reagent adds to a multiple bond; the π -bond is broken and σ -bonds are formed between the reagent and the atoms in the multiple bond, such as addition of hydrogen to an alkene (to give an alkane) or an alkyne (to give an alkene) or a ketone (to give an alcohol). It is a reaction in which a π -bond is broken and replaced by two bonds.

Alcohols. They are compounds with a hydroxyl group.

Aldehydes. Compounds with at least one hydrogen atom bonded to the carbon of a carbonyl group.

Aldol condensation. A reaction in which an enolate anion adds to the carbonyl group of an aldehyde or ketone to give an aldol.

Alkadienes. Unsaturated hydrocarbons with two carbon-carbon double bonds.

Alkanes. Saturated hydrocarbons those are acyclic.

Alkenes. Unsaturated hydrocarbons with one carbon-carbon double bond.

Alkoxy group. The functional group $-\text{OR}$.

Alkyl groups. Saturated substituents containing only carbon and hydrogen atoms derived by removal a hydrogen atom from an alkane.

Alkyl halide. A compound with a carbon-halogen bond; usually restricted to compounds where the carbon-halogen bond involves a sp^3 -hybridized carbon atom.

Alkynes. Unsaturated hydrocarbons with one carbon-carbon triple bond.

Allyl group. The $\text{CH}_2=\text{CHCH}_2-$ group

Amides. Carboxylic acid derivatives in which the $-\text{OH}$ group is replaced by $-\text{NH}_2$, $-\text{NHR}$, or $-\text{NR}_2$.

Amines. Organic bases derived from ammonia; primary amines (RNH_2) have an alkyl or aryl group bonded to an amino group; secondary (R_2NH) and tertiary amines (R_3N) have two and three groups bonded to nitrogen.

Amino group. The functional group $-\text{NH}_2$.

Amphoteric compounds. Substances that can act as an acid or as a base.

Aromatic hydrocarbons. Unsaturated hydrocarbons structurally related to benzene.

Aromaticity. The unusual stability of certain fully conjugated cyclic systems.

Aryl halide. An organic halide with the halogen atom directly bonded to an aromatic ring.

Atomic orbital. The spaces occupied by electron pairs or unpaired electrons in atoms.

Axial. The six positions perpendicular to the mean plane of the ring in the chair conformation of a six-membered ring; for example, in cyclohexane.

Azo group. The $-\text{N}=\text{N}-$ group.

B

Benzoyl group. The $\text{C}_6\text{H}_5\text{CO}-$ group.

Benzyl group. The $\text{C}_6\text{H}_5\text{CH}_2-$ group.

Bond angle(s). The angle made by two covalent bonds to the same atom.

Bond length(s) The average distance between two covalently bonded atoms.

Bronsted-Lowry acid. A proton donor.

Bronsted-Lowry base. A proton acceptor.

C

Carbanion(s). An alkyl or aryl group with a negatively charged carbon atom.

Carbocation(s). An electron-deficient cationic intermediate in which one carbon atom has a formal positive charge and only six valence electrons.

Carbocyclic compounds. Compounds that contain rings of carbon atoms.

Carbohydrates. Originally, compounds such as aldoses and ketoses, having the stoichiometric formula $C_n(H_2O)_n$, hence "hydrates of carbon". The generic term carbohydrate includes monosaccharides, oligosaccharides and polysaccharides as well as substances derived from monosaccharides by reduction of the carbonyl group (alditols), by oxidation of one or more terminal groups to carboxylic acids, or by replacement of one or more hydroxy group(s) by a hydrogen atom, an amino group, thiol group or similar groups. It also includes derivatives of these compounds.

Carbonyl group. The functional group $C=O$.

Carboxyl group. The functional group— CO_2H , generated by attachment of a hydroxyl group to the carbon atom of a carbonyl group.

Carboxylic acid(s). Compounds with a carboxyl group.

Catalysts. Compounds that change the rate of a reaction but can be recovered unchanged at the end of the reaction.

Chair conformation(s). The most stable conformation of a six-membered ring in which all bonds are staggered; the chair conformation of cyclohexane.

Configurational isomers. *Stereo isomers* that can be interconverted only by breaking and remaking bonds:

cis-trans isomers in alkenes or cycloalkanes, structural isomers such as 1-bromopropane and 2-bromopropane,

enantiomers such as (D)-2-bromobutane and (L)-2-bromobutane, or any pair of *diastereomers*.

Conformational isomers. Isomers that can be interconverted by rotation around single bonds.

boat — flexible conformation of a cyclohexane ring. *chair* - rigid conformation of a cyclohexane ring in which every carbon-carbon bond is in a butane gauche conformation.

eclipsed — a conformation in which the σ bonds to the groups at one end of a bond exactly superimpose on the σ bonds to the groups at the other end; the dihedral angle is 0° .

gauche — a staggered conformation in which the two largest groups are not as far apart as possible (torsional angle 60°).

staggered — a conformation in which the σ bonds to the groups at one end of a bond are spaced equidistant from the two nearest σ bonds to the groups at the other end of the bond; the dihedral angle is 60° .

Conjugate acid. The product of protonation of a given base is the conjugate acid of that base.

Conjugate base. The product of deprotonation of a given acid is the conjugate base of that acid.

Conjugation. Multiple bonds that are separated by one single bond ($C = C - C = C$ or $C = C - C = O$).

Covalent bond(s). A bond in which two atoms share one or more electron pairs; C — C, C — H, or N — N.

Cumulated bonds. Double bonds that are next to each other (C=C=C).

Cyano group. The —C=N group.

Cycloalkanes. Saturated hydrocarbons, that contain rings of carbons atoms.

D

Deactivating groups. Substituents that, when on a benzene ring, slow the rate of electrophilic aromatic reactions relative to benzene; nitro, halogen, and acyl groups.

Disaccharides are condensation products of two monosaccharide units. (maltose, lactose, sucrose)

Double bond(s). A bond in which two electron pairs are shared between the same two atoms; C=C or C=O.

E

Electrofilic addition reaction (A_E). A reaction in which an electrophile adds to a carbon-carbon multiple bond.

Electronegativity. The tendency of atoms to accept electrons and form anions; the greater the electronegativity, the more the atom accepts electrons.

Electrophiles. Electron-poor reactants: they seek electrons and form bonds to nucleophiles.

Electrophilic aromatic substitution (S_E). A reaction of an aromatic compound with an electrophile that gives a substituted aromatic compound.

Elimination (E). A reaction in which two bonds on adjacent atoms are cleaved and in which a π -bond is formed.

Epimers Diastereomers that differ in 1 configuration at only one stereogenic center.

Equatorial. The six positions parallel to the mean plane of the ring in the chair conformation of a six-membered ring; for example, in cyclohexane.

Ester(s) Carboxylic acid derivatives in which the hydroxyl group is replaced by an alkoxy (OR) group.

Ethers. Compounds with two alkyl or aryl groups bonded to the same oxygen (R—O—R)

Ethyl group. The alkyl group CH₃CH₂—.

F

Fatty acids. Long-chain carboxylic acids obtained from saponification of fats and oils.

Fluoro group. The group F— .

Formal (partial) charge. The formal charge of an atom in a molecule, which is equal to the number of valence electrons in the neutral atom, minus the number of covalent bonds to the atom, minus the number of unshared electrons on the atom.

Formyl group (methanoyl group). The —CHO group.

Free-radical chain reaction (S_R). A reaction that involves free radical intermediates and involves propagation steps, the sum of which constitutes the overall equation for the reaction.

Functional group is an atom or small group of atoms in a molecule that gives the molecule characteristic chemical properties or **Functional groups are** groups of atoms that have characteristic chemical properties regardless of the molecular framework to which they are attached; usually characteristic of a class of organic compounds.

H

Hemiacetal(s). A compound with one alkoxy group and one hydroxyl group bonded to the same carbon atom.

Heterocyclic compounds. Cyclic compounds in which one or several carbon atoms are replaced by heteroatoms (O, S or N atoms).

Homologous series. A series of compounds that grow by addition of a regular unit of structure and share similar properties; for example, methane, ethane, propane, and so on represent a homologous series of alkanes, where in the regular unit of structure is a methylene group.

Hybrid Atomic Orbitals. Orbitals formed by mixing the wave functions of pure s - and p -orbitals of an atom. There are three major types of hybrid atomic orbital which occur in organic compounds, all of which are characterized by having a large front lobe and a small back lobe:

sp — obtained by combining the wave function of one s -orbital with the wave function of one p -orbital. Two collinear hybrid orbitals oriented in opposite directions are formed. The unused p orbitals are perpendicular to the line defined by the two hybrid orbitals.

sp^2 — formed by combining the wave function of one s -orbital with the wave functions two p -orbitals. Three coplanar hybrid orbitals oriented towards the vertices of an equilateral triangle are formed. The unused p orbital is perpendicular to the plane defined by the three hybrid orbitals.

sp^3 — formed by combining the wave function of one s -orbital with the wave functions of three p -orbitals. Four hybrid orbitals oriented towards the vertices of a tetrahedron are formed.

Hydration. The addition of the elements of water across a double bond.

Hydrocarbons. Organic compounds, those contain only carbon and hydrogen atoms.

Hydrogen bond. An attractive interaction that occurs between hydrogen atoms bonded to highly electronegative atoms (O, N, F) and the nonbonding electron pairs on other highly electronegative atoms.

Hydrogenation. Addition of hydrogen to a multiple bond with the aid of a catalyst. The addition of the elements of hydrogen across a double bond.

Hydrogen bond. An attractive interaction that occurs between hydrogen atoms.

Hydrophilic. A polar group which tends to water.

Hydroxyl group (hydroxy group). The functional group —OH.

I

Inductive effect. An effect that results from the electron-donating or electron-withdrawing properties of nearby substituents. It's an effect of electro negativity spread in simple bonds.

Isomers. There are molecules with the same number and kinds of atoms but different arrangements of the atoms.

IUPAC. International Union of Pure and Applied Chemistry.

K

Ketones. Compounds with two carbon atoms bonded to the carbon of a carbonyl group.

L

Leaving group. An atom or group of atoms that leaves from a substrate (along with a pair of electrons) in a nucleophilic substitution reaction (S_N).

Lewis Acid. An electron-pair acceptor.

Lewis Base. An electron-pair donor.

Lipids (from *greek* "lipos" — fat) are constituents of plants and animals that are characterized by their solubility properties.

M

Markovnikov's Rule. When an unsymmetrical reagent adds to an unsymmetrical alkene, the more positive part of the reagent adds to the less substituted end of the alkene; electrophiles add to alkenes so that the more stable carbocation is formed.

Mechanism. It is a detailed, step-by-step description of the course of a reaction.

Mercapto group. The functional group —SH.

Meta-directing group. A substituent on benzene that directs an electrophile to *meta*- positions on the ring.

Methyl group. The alkyl group CH_3 —.

Molecular formula. The number of different atoms present in a molecule.

Monosaccharides are polyhydroxyl aldehydes (aldoses) and polyhydroxy ketones (ketoses). According to the number of carbon atoms present they are: triose, tetrose, pentose, hexose. In nature pentoses and hexoses are most abundant.

Multiple bonds. Double and triple bonds.

N

Nitro group. The —NO_2 .

Nucleic acids are defined as macromolecules built up from mononucleotides linked to form giant molecules

Nucleophile. An electron-pair donor; a Lewis base. It's an electron rich reactant that forms bonds by sharing electrons with electrophiles.

Nucleophilic acyl substitution. A substitution reaction in which the hydroxyl group of a carboxylic acid is replaced with another group; also used in reference to conversion of one carboxylic acid derivative to another carbonyl compound.

Nucleophilic addition (A_N). It is a two-step reaction in which the first step is the addition of a nucleophile to the π -bond.

Nucleophilic substitution reaction (S_N). A reaction in which a nucleophile displaces a leaving group from a substrate, or it is a reaction in which a leaving group is displaced by a nucleophile.

Nucleosides are N-glycosides, in which the pyrimidine or purine base is connected to the anomeric carbon ($C^{\prime}-1$) of the sugar.

Nucleotides are phosphate esters of nucleosides. A hydroxyl group in the sugar part of a nucleoside is esterified with phosphoric acid either at 5' or the 3'-positions.

Nucleotides are phosphate esters of nucleosides. A hydroxyl group in the sugar part of a nucleoside is esterified with phosphoric acid either at 5' or the 3'-positions.

O

Oligosaccharides are condensation products of two to ten monosaccharide units.

Organic chemistry. The chemistry of carbon compounds, or it's the chemistry of the hydrocarbons and their derivatives.

Ortho, para-directing group. A substituent on benzene that directs an electrophile to *ortho* and *para*-positions on the ring.

Oxidation reaction(s). A reaction that increases the oxidation state of atoms in a molecule or ion. In organic chemistry this frequently involves reactions in which C—H bonds are replaced by C — O bonds. It is a net decrease in the number of bonds to hydrogen or electropositive elements, or a net increase in the number of bonds to electronegative elements. A net loss of electrons.

P

Peptides are natural or synthetic substances built up of α -amino acids residues which are linked by amide (peptide) bond. **The primary structure of proteins** is the sequence of amino acids residues in a completely assembled polypeptide chain.

Periodic Law. The physical and chemical properties of elements recur periodically as a function of the atomic number of the element.

Phenols. Compounds with a hydroxyl group attached to an aromatic benzene ring.

Phenyl group. The C_6H_5- group.

Polar bond. A covalent bond between two atoms of different electronegativity in which the electron pair is unevenly shared. The two atoms participating in polar bonds both bear partial charges, one positive (δ^+) and one negative (δ^-).

Polyelectrolytes containing both acidic and basic ionisable groups are known as amphoteric electrolytes.

Polysaccharides are condensation products of more than ten monosaccharide units.

Proton(s). Positively charged particles that reside in the nucleus of an atom.

Purines. Biologically important heterocyclic compounds containing a pyrimidine ring fused to an imidazole ring.

Pyridines. Six-membered ring aromatic heterocycles containing one N-atom.

Pyrimidines. Six-membered ring aromatic heterocycles containing two N-atoms at ring positions.

R

Racemic mixture. A 50:50 mixture of enantiomers.

Radical (or free radical). A molecular fragment with an odd number of unshared electrons; for example, $CH_3\cdot$.

Reaction mechanism. A step-by-step description of the bond-breaking and bond-making processes that occur when reagents react to form products.

Reaction rate. How fast a reaction takes place.

Reduction. It is a net increase in the number of bonds to hydrogen or electropositive elements, or a net decrease in the number of bonds to electronegative elements. A net gain of electrons.

S

Saitseff's Rule. In an elimination reaction where two regioisomeric alkenes can be formed, the major regioisomer will be the more substituted alkene.

Saponification. The reaction of fats and oils with aqueous sodium hydroxide to give glycerol and sodium salts of fatty acids (soaps); also used in reference to hydrolysis of any ester. **Saponification** of lipids is hydrolysis, which occurs in basic media and gives a mixture of salts of fatty acids and glycerol.

Saturated hydrocarbons. Hydrocarbons that contain only carbon-carbon single bonds (no multiple bonds).

sec-Butyl group. The $\text{CH}_3\text{CH}_2\text{CH}(\text{CH}_3)\text{—}$ group.

Sigma-bond (σ -bond). A bond formed by end-on overlap of two orbitals on adjacent atoms. Electron density in a σ -bond is space around a line connecting the adjacent atoms.

Soaps. The salts (usually sodium) of long-chain fatty acids.

sp^2 -Hybrid orbitals. Orbitals that are one part s and two parts p in character and are directed, from the atom to which they belong, toward the three vertices (corners) of an equilateral triangle. The angle between two-hybrid orbitals is 120° .

sp -Hybrid orbitals. Orbitals that are one part s and one part p in character and are directed, from the atom to which they belong, in opposite directions along a line. The angle between two sp -hybrid orbitals is 180° .

sp^3 -Hybrid orbitals. Orbitals that are one part s and three parts p in character and are directed, from the atom to which they belong, toward the corners of a tetrahedron. The angle between such orbitals is 109.5° .

Stereoisomers Isomers with the same attachment of atoms but different arrangements of atoms in space — for example, *cis-trans* isomers of alkenes or cycloalkanes, conformational isomers of alkanes, a pair of enantiomers, or a pair of diastereomers.

Stereogenic carbon atom (stereogenic center) A carbon atom to which four different groups are attached. **Substituents.** Groups attached to the main chain of a molecule.

Substitution reaction(s). A reaction in which one atom or group of atoms is replaced with another atom or group of atoms.

T

Tautomerism The process of inter-conversion of tautomers, such as keto and enol forms of a carbonyl compound.

Tautomers Structural isomers that differ in the location of a proton and a double bond.

tert-Butyl group. The $(\text{CH}_3)_3\text{C—}$ group.

Tetrahedral carbon. When a carbon atom is bonded to four other atoms.

The Adamkevitch Reaction — a dark-violet ring in the interface appears when protein is treated with a mixture of concentrated acetic and glyoxilic acids. This reaction occurs due to and tryptophan presence in proteins.

The Biuretic Test on peptide bonds — proteins solutions turn violet when treated with a base and copper (II) sulfate solutions.

The Melon reaction — proteins solutions turn brick red when treated with a reagent consist from mercury (II) nitrate and mercury (II) nitrite. This reaction occurs due to tyrosine presence in proteins.

The Ninhydrin Reaction — proteins and α -amino acids solutions turn violet when treated with ninhydrin under heating.

The Phol Reaction — black colored lead salt precipitates from protein solution when it is treated with $(\text{CH}_3\text{COO})_2\text{Pb}$ in basic medium. This reaction occurs due to sulfur containing amino acids contained in proteins.

The primary structure of nucleic acids is the sequence of mononucleotide units linked through phosphodiester bonds.

The Xanthoprotenic Reaction — proteins solutions turn yellow when treated with concentrated nitric acid under heating. This reaction occurs due to tyrosine and tryptophan presence in proteins.

Trigonal carbon. When a carbon atom is bonded to only three other atoms, as the carbon $\text{C}=\text{C}$ and $\text{C}=\text{O}$ groups.

Triple bond. A bond in which three electron pairs are shared between the same two atoms; for example, $\text{C}\equiv\text{C}$ or $\text{C}\equiv\text{N}$.

U

Unsaturated hydrocarbons. Hydrocarbons that contain multiple bonds; for example, carbon-carbon double and/or triple bonds.

V

Vinyl halide. An organic halide with the halogen atom directly bonded to a double bond.

Appendix 1 — Formulas for chemistry seminars

| Topic of the seminar | Learn by heart the following formulas: |
|---|--|
| Configurations and conformations of organic compounds | γ -aminobutyric acid, Isoleucine (Ile), Valine (Val), Alanine (Ala), Ethyldiol-1,2, acetone, Oxaloacetic acid, α -Ketoglutaric acid, Menthol, Xylitol, Methanol, Ethanol, Ethanolamine (Colamine), Iodoform, Chloroform, Hexachloran, Inosit |
| Conjugated and aromatic systems | Imidazole, Pyrrole, Furan, Thiofene, Pyroazole, Pyrimidine, pyridine, Purine Antracene, Fhenantrene, Naphthalene, Azylene, Aniline, Benzene, Phenol, Cycloheptatrienyl cation, Cyclopentadienyl anion |
| Classification and mechanism | Steric acid, Palmitinic acid, Oleic acid, Linoleic acid or Lenolic acid, Linolenic acid, Arachidonic acid, p- sulfanilic acid |

| | |
|---|--|
| of organic reactions | |
| Acidity and basicity of organic compounds | BAL, Novocain, Adrenaline, Noradrenalin, Formic or methanoic acid, Acetic or ethanoic acid, Propionic or propanoic acid, Butyric or Butanoic acid, Valeric or Pentanoic acid, Palmitinic acid |
| Properties of aldehydes and ketones | Aldehydes and ketones |
| Carboxylic acids and their derivatives | Saturated dicarboxylic acids, Aromatic carboxylic acids, Unsaturated carboxylic Acid, Unsaturated dicarboxylic acids |
| Heterofunctional aromatic compounds | Anesthesine, Novocain, Sulfanilamide, Aspirin (Acetylsalicylic acid); p-sulfanilic acid, salicylic acid, Nicotinic acid, PABA |
| Heterofunctional aliphatic compounds | Keto carboxylic acids, Hydroxy carboxylic acids |
| Heterofunctional heteroaromatic compounds | Aromatic & Conjugated Molecules, Hetero functional compounds |
| Lipids | Choline, glycerol, phosphatidylethanolamine (cephaline), Phosphatidylcholine (lecithin), General formula for phospholipids, Acetylcholine, Acetyl Co A (Acetyl coenzyme A), serine, sphingosine |
| Monosaccharides | Sorbitol, D-glucose, D-galactose, D-mannose, D-fructose, D-ribose, D-deoxyribose, D-Gluconic acid, D-Glucaric acid (You must write the Fisher projection, the Haworth projection (α - and β -formula) for all Monosaccharides) |
| Di- and polysaccharides | Maltose, lactose, sucrose, starch, glycogen, cellulose, Dextrans, Chondroitin sulfate, Hyaluronic acid |
| α - Amino Acids | α -Amino Acids |
| Peptides and proteins | α -Amino Acids |
| Nucleic Acids | Guanine, Adenine, Uracil, Thymine, Cytosine, Nicotinamide adenine dinucleotide or NAD^+ , Adenosine-3'-5'-cyclic monophosphate or cyclic AMP or c-AMP, Adenosine-5'-monophosphate or AMP, ATP |
| Steroids and alkaloids | Cholesterol, Steroid ring |

Appendix 2 — The most important functional groups and the decrease of their priority

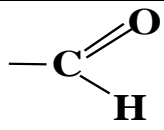
| Functional group | Name of a functional group | |
|---|----------------------------|----------------------|
| | In prefix | In ending |
| $-\text{COOH}$ | Carboxy- | -oic acid |
| $-\text{SO}_3\text{H}$ | Sulfo- | Sulfonic acid |
| $-\text{C} \equiv \text{N}$ | Cyano- | -nitrile |
|  or $-\text{CHO}$ | Oxo- | -al |

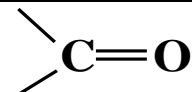
| | | |
|---|------------------|---------------|
|  | Oxo- | -one |
| -OH | Hydroxy- | -ol |
| -SH | Mercapto- | -thiol |
| -NH ₂ | Amino- | -amine |
| =NH | Imino- | -imine |

Appendix 3 — Inductive and Resonance effects

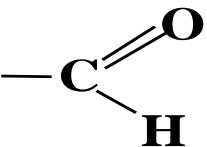
| Function groups and other structures | Inductive effect | Resonance effect |
|---|-------------------------|-------------------------|
| Alkyl radical | +I | - " - " - " |
| -NH ₂ , -NHR, -NR ₂ | -I | +R |
| RO- | -I | +R |
| Halogens | -I | +R |
| -OH | -I | +R |
| -NO ₂ | -I | -R |
| -COOH | -I | -R |
| -SO ₃ H | -I | -R |
| -C ₆ H ₅ | -I | -R |
|  | -I | -R |

Appendix 4 — K_a and pK_a for acids

| Acid | pK_a | K_a |
|--------------------------------|-----------------------|----------------------|
| HClO | 7.25 | 5.6×10 ⁻⁸ |
| HCl | -7 | 1.0×10 ⁷ |
| H ₂ SO ₄ | -3 | 1.0×10 ³ |
| H ₃ O ⁺ | -1.74 | 55 |
| HNO ₃ | -1.32 | 21 |
| H ₂ SO ₃ | 1.92 | 0.012 |
| HF | 3.13 | 7.2×10 ⁻⁴ |
| HNO ₂ | 3.15 | 7.1×10 ⁻⁴ |

| | | |
|---|------|-----------------------|
| HCOOH | 3.70 | 2.2×10^{-4} |
| CH ₃ COOH | 4.75 | 1.8×10^{-5} |
| HCN | 9.00 | 1.0×10^{-9} |
| H ₃ BO ₃ | 9.14 | 7.3×10^{-10} |
| NH ₄ ⁺ | 9.25 | 5.6×10^{-10} |
| H ₂ SiO ₄ | 9.5 | 3.2×10^{-10} |
| H ₂ CO ₃ | 6.52 | 3.0×10^{-7} |
| HCO ₃ ⁻ | 10.4 | 4.0×10^{11} |
| H ₃ PO ₄ | 1.96 | 0.011 |
| H ₂ PO ₄ ⁻ | 7.12 | 7.6×10^{-8} |
| HPO ₄ ²⁻ | 12.3 | 4.8×10^{-13} |
| H ₂ S | 6.92 | 1.2×10^{-7} |
| HS ⁻ | 13 | 1.0×10^{-13} |

Appendix 5 — pK_b values

| Base | Formule | pK _b |
|---------------|--|-----------------|
| Ammonia | NH ₃ | 4.75 |
| Aniline | C ₆ H ₅ NH ₂ | 9.37 |
| Diethylamine | (C ₂ H ₅) ₂ NH | 3.02 |
| Dimethylamine | (CH ₃) ₂ NH | 3.27 |
| Ethylamine | C ₂ H ₅ NH ₂ | 3.19 |
| Methylamine | CH ₃ NH ₂ | 3.36 |
| Pyridine | C ₅ H ₅ N | 8.37 |
| Urea | H ₂ NCONH ₂ | 13.82 |

LITERATURE

1. *Clayden, J. N. Wothers Organic Chemistry / J. N. Clayden, S. Greeves, P. Warren.* — Oxford Press, 2005.
2. *Harild Hart and other. Organic chemistry (A Short Course).* — Tenth edition. — 2003.
3. *Harold Hart and other. Organic chemistry (A Short Course).* — Tenth edition. — 2002.
4. *Holum. J. Fundamentals of General, Organic and Biological Chemistry / J. Holum.* — USA, 1977.

5. *Malone, Leo J.* Basic concepts of chemistry / Leo J. Malone. — Fourth education, 1994.
6. Morrison and Boyd. Organic chemistry. — Fourth edition. 1987.
7. *Schuets, H.* Organic chemistry / Hart Schuets. — Fifth edition, 2006.
8. *Tikavy, V.* General chemistry in formulas, definitions, and diagrams / V. Tikavy. — St. Peterburg, 2000.

Учебное издание

Филиппова Валентина Анатольевна
Чернышева Людмила Викторовна
Лысенкова Антонина Владимировна

БИООРГАНИЧЕСКАЯ ХИМИЯ
(на английском языке)

Учебно-методическое пособие
для студентов 1 курса лечебного факультета,
обучающихся на английском языке, медицинских вузов

Редактор *Т. М. Кожемякина*
Компьютерная верстка *А. М. Терехова*

Подписано в печать 02.12.2015.
Формат 60×84¹/₁₆. Бумага офсетная 65 г/м². Гарнитура «Гаймс».
Усл. печ. л. 14,42. Уч.-изд. л. 15,76. Тираж 100 экз. Заказ № 368.

Издатель и полиграфическое исполнение:
учреждение образования «Гомельский государственный медицинский университет».
Свидетельство о государственной регистрации издателя,
изготовителя, распространителя печатных изданий № 1/46 от 03.10.2013.
Ул. Ланге, 5, 246000, Гомель.